



**EMERGENCY  
NUMBER  
SYSTEMS BOARD**

**9-1-1**

**ANNUAL REPORT  
2008**

MARTIN O'MALLEY  
GOVERNOR

ANTHONY G. BROWN  
LT. GOVERNOR

GARY D. MAYNARD  
SECRETARY - DPSCS

DEPARTMENT OF PUBLIC SAFETY AND CORRECTIONAL SERVICES





## Department of Public Safety and Correctional Services

### Office of the Secretary

300 E. JOPPA ROAD • SUITE 1000 • TOWSON, MARYLAND 21286-3020  
(410) 339-5000 • FAX (410) 339-4240 • TOLL FREE (877) 379-8636 • V/TTY (800) 735-2258 • [www.dpccs.state.md.us](http://www.dpccs.state.md.us)

STATE OF MARYLAND

MARTIN O'MALLEY  
GOVERNOR

ANTHONY G. BROWN  
LT. GOVERNOR

GARY D. MAYNARD  
SECRETARY

G. LAWRENCE FRANKLIN  
DEPUTY SECRETARY

DIVISION OF CORRECTION

DIVISION OF PAROLE AND  
PROBATION

DIVISION OF PRETRIAL  
DETENTION AND SERVICES

PATUXENT INSTITUTION

MARYLAND COMMISSION ON  
CORRECTIONAL STANDARDS

CORRECTIONAL TRAINING  
COMMISSION

POLICE TRAINING  
COMMISSION

MARYLAND PAROLE  
COMMISSION

CRIMINAL INJURIES  
COMPENSATION BOARD

EMERGENCY NUMBER  
SYSTEMS BOARD

SUNDRY CLAIMS BOARD

INMATE GRIEVANCE OFFICE

April 30, 2009

The Honorable Martin O'Malley  
Governor of the State of Maryland  
100 State Circle  
Annapolis, Maryland 21401-1991

Dear Governor O'Malley:

I am pleased to forward to you the Emergency Number Systems Board's FY 2008 Annual Report as required by the Public Safety Article of the *Annotated Code of Maryland*. The report outlines the activities, progress, and challenges the Board must address to provide quality 9-1-1 services to the people of Maryland.

I am proud to say that Maryland has a robust 9-1-1 System that annually receives over five million requests for emergency services. The Emergency Number Systems Board (ENSB) continues to provide funding directed to system enhancements, equipment replacements, and training mandates to ensure reliable and adequate capacity is available for 9-1-1 service.

The Emergency Number Systems Board continues its efforts to modernize Maryland's 9-1-1 system to keep pace with evolving technology. The Board is poised to take advantage of Next Generation 9-1-1 technologies as they emerge to remain responsive to the needs of our citizens and visitors.

The Emergency Number Systems Board and I are very proud of the achievements accomplished in the past year. We thank you for your ongoing support and leadership and look forward to the continued advancement of public safety.

Sincerely,

Gary D. Maynard  
Secretary



## Department of Public Safety and Correctional Services

### Emergency Number Systems Board

115 Sudbrook Lane – Suite 201, Pikesville, Maryland 21208-4199  
(410) 585-3015 • FAX (410) 764-4136 • [www.dpscs.state.md.us/ensb/](http://www.dpscs.state.md.us/ensb/)

MARTIN O'MALLEY  
GOVERNOR

ANTHONY G. BROWN  
LT. GOVERNOR

GARY D. MAYNARD  
ACTING SECRETARY

G. LAWRENCE FRANKLIN  
DEPUTY SECRETARY

ANTHONY MYERS  
CHAIRMAN

GORDON DEANS  
EXECUTIVE DIRECTOR

JUMARY WEST  
FISCAL COORDINATOR

HOWARD REDMAN  
TRAINING COORDINATOR

April 22, 2009

Secretary Gary Maynard  
Department of Public Safety and Correctional Services  
300 East Joppa Road - Suite 1000  
Baltimore, MD 21286

Dear Secretary Maynard:

I am pleased to provide you with the Annual Report of the Emergency Number Systems Board for Fiscal Year 2008. The Board has assembled monthly and more often-in sub-committees, to consider a variety of 9-1-1 related issues and projects. The attached report outlines the collective efforts of the 911 community in making Maryland a safer place for its residents and visitors.

Recent Board efforts include upgrading mapping technology at Public Safety Answering Points (PSAPs), formally examining "Next Generation" 911 technologies, providing a variety of training opportunities for 911 call takers, further defining standards and funding opportunities for 9-1-1 back-up facilities and continuing to implement call processing protocol technology. The Board is pleased to report that Maryland continues to enjoy an effective 911 system.

The Board remains focused on the enhancement of 911 and the critical role it plays in public safety. On behalf of the members of the Emergency Number Systems Board and the more than nine hundred call takers around the state, I thank you for your continued support and the diligent assistance your staff routinely provides.

The attached document and appendices constitute the 2008 Annual Report of the Emergency Number Systems Board as required by the Public Safety Article.

Sincerely,

A handwritten signature in black ink that reads "Anthony Myers". The signature is written in a cursive, flowing style.

Anthony Myers, Chairman  
Emergency Numbers Systems Board

# ***TABLE OF CONTENTS***

---

<b><i>INTRODUCTION</i></b> .....	1
<b><i>EXECUTIVE SUMMARY</i></b> .....	3
<b>PUBLIC SAFETY ARTICLE</b> .....	5
<b>THE CODE OF MARYLAND REGULATIONS</b> .....	7
<b><i>HISTORY OF 9-1-1 IN MARYLAND</i></b> .....	8
<b><i>BOARD MEMBERSHIP</i></b> .....	12
<b><i>TYPES OF 9-1-1 SYSTEMS</i></b> .....	14
<b><i>FUNDING</i></b> .....	16
<b><i>ENSB BUDGETED EXPENDITURES</i></b> .....	19
<b><i>COUNTY AUDITS</i></b> .....	22
<b><i>MANAGING FOR RESULTS</i></b> .....	23
<b><i>MSP NEXT GENERATION 9-1-1 FEASIBILITY PROJECT</i></b> .....	25
<b><i>TRAINING SUBCOMMITTEE</i></b> .....	27
<b><i>POLICY SUBCOMMITTEE</i></b> .....	31
<b><i>TECHNOLOGY SUBCOMMITTEE</i></b> .....	32
<b><i>STANDARDS SUBCOMMITTEE</i></b> .....	34
<b><i>ENSB/MENA DAY OF CELEBRATION</i></b> .....	35

## **Appendix**

<b>PUBLIC SAFETY ARTICLE</b> .....	37
<b>C.O.M.A.R</b> .....	47

## ***INTRODUCTION***

The Emergency Number Systems Board's (ENSB or Board) duties are defined by Sections §1-301 through §1-312 of the Public Safety Article of the Annotated Code of Maryland. Those duties include coordinating the enhancement of County 9-1-1 systems and the oversight of the 9-1-1 Trust Fund. This report details the activities of the Board and Trust Fund expenditures from July 1, 2007 to June 30, 2008.

The Public Safety Article requires that the following six topics be included in the annual report:

1.	Types of 9-1-1 Systems in Operation	Page 14
2.	Total State and County Fees Charged	Page 16
3.	Funding Formula in Effect by County	Page 17
4.	Statutory or Regulatory Violations by County	None Noted
5.	Establishing a Next Generation 9-1-1 System	Page 25
6.	Any Suggested Changes to this Subtitle	Page 5

This report goes significantly beyond these six areas in an effort to provide additional insight into the work of the Emergency Number Systems Board. As the communications industry introduces new technological enhancements, Maryland's 9-1-1 system continues to evolve to ensure that Maryland's citizens and visitors are afforded a robust and responsive system when they call 9-1-1. Since many of the activities of the Board go beyond the scope of the statutory reporting requirements, this report includes references to additional efforts to promote the reader's knowledge of the Board's work.

The mission of the ENSB, at its inception, was to provide guidance and direction with the goal of realizing "enhanced" service in all of Maryland's PSAPs. Enhanced is defined by the statute as having the capacity for the 9-1-1 call taker to view automatically displayed callback number and location information, either in the form of an address or more recently the latitude and longitude for mapping the location. This statewide goal was achieved for wireline calls in 1998 and for wireless calls in June 2005 when wireline and wireless enhanced 9-1-1 service became available to all Maryland communities.

### **ENSB MISSION STATEMENT**

***The Emergency Number Systems Board works cooperatively with the counties to provide an effective and efficient Maryland 9-1-1 system through the administration of the 9-1-1 Trust Fund revenues.***

The current direction of the Board is to evaluate and fund local jurisdiction plans for enhancements consistent with the Public Safety Article, Board guidelines, the availability of Trust Fund dollars, and technological advancements. The Board is examining the following current issues:

- The proliferation of wireless communications systems;
- Integration of mapping technologies;
- The evolution of Internet Protocol (IP) based communication systems (VoIP);
- Establishing back-up facilities and other Homeland Security initiatives;
- Training and “protocol” software enhancements that promote standardization of 9-1-1 call processing throughout the State; and
- The feasibility of integrating “Next Generation” IP based 9-1-1 service delivery of voice, text, data, and video messaging in Maryland.

The engagement of local leadership has created a positive and constructive working relationship among Maryland’s PSAP community, its legislative delegations, its first responder community, and the Department of Public Safety and Correctional Services to collectively address these issues.

### **ENSB VISION STATEMENT**

*The Emergency Number Systems Board is dedicated to ensuring Maryland’s 9-1-1 system remains robust and responsive to the public-safety needs of our citizens and visitors. The Board is committed to providing fiscally responsive funding to maintain a technologically advanced 9-1-1 system staffed with appropriately trained emergency operators. Through a partnership with the 9-1-1 community, the Board will provide leadership and guidance for Maryland to be recognized nationally for excellence in providing 9-1-1 service.*

Questions regarding this report and its content should be forwarded to the ENSB Office of the Executive Director at 115 Sudbrook Lane – Suite 201, Pikesville, Maryland 21208.

The ENSB web site is:

[www.dpscs.state.md.us/ensb](http://www.dpscs.state.md.us/ensb)

## ***EXECUTIVE SUMMARY***

---

Maryland's Public Safety Article §1-305 defines the membership of the Emergency Number Systems Board. In October 2008, Public Safety Article §1-305 was re-codified increasing the membership of the Board from fifteen to seventeen members. The two new positions include a representative for Maryland's geographical information systems and an additional member from emergency management services. Board members are drawn from private and public sectors representing all aspects of public safety and the citizens they serve. The current membership of the Board includes a diverse group of police, fire, emergency management, regulatory, and communications industry professionals. The members serve a Governor appointed Senate confirmed, four-year term without compensation. While only required to meet quarterly, the ENSB meets at least monthly to examine current trends and needs of Maryland's Public Safety Answering Points (PSAP).

The proliferation of wireless devices and advancements in modern communications technologies have created the need for a more sophisticated 911 system. The existing 911 infrastructure has performed admirably for decades, however new data rich communications devices are driving the existing 911 infrastructure towards its operational limits. Consumers are increasingly relying on new wireless and IP-based communications technologies, which offer expanded data capabilities such as text, picture, and video messaging. The Board continues to examine the development of a Next Generation 911 system that would capture the benefits of expanding mobile and data communications technologies, as well as continuing to meet the current needs of 9-1-1 callers.

Some of the more prominent achievements and current activities of the ENSB include:

- Securing statewide regulatory compliance through annual Public Safety Answering Point (PSAP or 9-1-1 Center) inspections;
- Interacting with federal agencies and national organizations to consider evolving 9-1-1 issues;
- Encouraging counties to secure additional funding resources to augment the 9-1-1 Trust Fund;
- Providing ongoing training on new 9-1-1 technologies and evolving 9-1-1 service delivery techniques, offering 25 training opportunities attended by 539 students;
- Working in cooperation with the Maryland State Highway Administration to distribute the latest statewide aerial-photography to assist Maryland counties to update and maintain the accuracy of their mapping capacity;
- Examining the roles of primary, secondary, and back-up PSAPs in order to maximize new technological advances in data sharing;
- Furthering the Managing for Results (MFR) goal and objective to implement emergency police and fire protocol systems at our PSAPs to provide 9-1-1 caller interrogation consistency coupled with an established quality assurance program; and

- Continuing to work with the Maryland State Police (MSP) to develop a RFP to explore “Next Generation” 9-1-1 Systems technologies for the development of a 9-1-1 Public Safety Network for transferring emergency calls.

To further facilitate the execution of the mission of the ENSB, the Board established several sub-committees, comprised of Board members and supporting consultative membership from outside the Board. These subcommittees include:

- **Training and Education** – to provide and enhance entrance level training for 9-1-1 dispatchers as well as in-service training for existing personnel;
- **Standards** – to provide guidance on best practices in selecting and purchasing PSAP equipment and providing funding guidelines;
- **Policy/Legislative** – to establish and publish policy guidance for ENSB membership and PSAP Directors and to make recommendations for Legislative changes; and
- **Technology** – to investigate current and future technological advancements impacting the delivery of 9-1-1 services.

The Board also enjoys membership and actively participates on two separate Maryland Boards. These include:

- **2-1-1 Board** – to provide input to the creation of a 2-1-1 system in Maryland and coordinating the transfer of possible emergency calls.
- **SEMSAC Board** – to assist the Statewide Emergency Medical Systems Advisory Council, comprised of representatives from organizations involved in providing emergency care services, provide advice and assistance to the SEMSAC Board.

The ENSB remains committed to supporting 9-1-1 in Maryland and believes Maryland has been well served by the excellent service 9-1-1 callers receive. Maryland continues to be a national leader in providing enhanced emergency wireline, wireless, and VoIP services. With the introduction of IP based telephony equipment, Maryland is again poised to embrace a new technology and work towards a smooth transition as “next generation” 9-1-1 systems and service is realized.



## **PUBLIC SAFETY ARTICLE**

---

The Maryland Public Safety Article (Title-1, Subtitle-3) is the enabling legislation that established the 9-1-1 Trust Fund and the Emergency Number Systems Board (ENSB or Board). It was originally crafted to create a funding mechanism and oversight Board to provide for the orderly installation, maintenance, and operation of 9-1-1 systems in Maryland and establish the three-digit number, 9-1-1, as the primary emergency telephone number to summon emergency assistance. The Public Safety Article remains responsive to the needs of the Maryland's citizens.

The legislation established the Maryland 9-1-1 Surcharge, derived from a monthly surcharge levied on each telephone bill, to provide a constant funding source for enhancing and maintaining Maryland's 9-1-1 system. The 9-1-1 Surcharge is comprised of two separate fees designated to offset 9-1-1 related capital and operational costs. The first portion of the Maryland 9-1-1 Surcharge is the "9-1-1 state fee". The state fee is distributed to the Maryland counties at the discretion of the Emergency Number Systems Board in response to county 9-1-1 system enhancement requests. The second portion is the "Additional Charge", which is determined by each county through local resolution. The Public Safety Article limits the "Additional Charge", to a maximum of \$0.75. Legislation requires that the amount of the additional charges received may not exceed a level necessary to cover the total eligible maintenance and operation costs of the county. The Public Safety Article further defines that maintenance and operation costs may include telephone company charges, equipment costs, equipment lease charges, repairs, utilities, personnel costs, and appropriate carryover costs from previous years. To ensure compliance, the Board shall provide for an audit of each county's expenditures for the maintenance and operation of the county's 9-1-1 system. All Maryland Counties have taken advantage of this legislative authority and have passed local resolutions establishing their "Additional Charge".

In 2003, this legislation was updated to provide the impetus and fiscal mandates for Maryland's 9-1-1 call takers to receive callback phone number and location information of wireless callers (defined as "enhanced wireless 9-1-1"). This milestone was achieved in June 2005 when Maryland became only the eighth state in the nation to receive and display enhanced wireless information, when available from a wireless carrier, at all primary Maryland PSAPs.

The 2003 revisions also expanded the definition of "9-1-1 assessable service" to include "telephone service or another communications service that connects an individual dialing the digits 9-1-1 to an established public safety answering point". This new definition expanded the communication service providers required to collect and remit the 9-1-1 surcharge to include carriers utilizing Internet Protocol technology (VoIP) for voice connectivity to 9-1-1 Centers.

In 2008, this legislation was revised to increase the membership of the Board from 15 to 17 members. Responding to technological advancements in geographical informational

systems (GIS) and the integration of wireless location technology into the 9-1-1 system, this legislation established a new Board position to represent the State's GIS community. Since 2001, the role and capacity of local emergency management services (EMS) and nationwide homeland security efforts have increased significantly. Since 9-1-1 has a vital function in identifying incidents where emergency management services are to be deployed, this legislation increased the EMS representation on the Board to two positions.

**The Public Safety Article is sufficient in its current content to be responsive to the needs of Maryland's 9-1-1 community and no further changes are recommended.**

# **THE CODE OF MARYLAND REGULATIONS**

---

The Code of Maryland Regulations (COMAR) Title 12, Subtitle 11, Chapter 03 further codifies the activities of the Board and describes in detail its essential functions, responsibilities, and training standards. In 2008, recommendations made by the Emergency Number Systems Board's Policy Subcommittee for updating COMAR were adopted. COMAR was updated to reflect changes recommended by the Emergency Number Systems Board's Policy Subcommittee. Significant updates include:

- Redundant wording of items appearing in COMAR that were verbatim to the Public Safety Article were removed and language added to reference the reader back to the appropriate section of the Public Safety Article;
- The Board requires a majority of confirmed members to be present at a meeting to constitute a quorum;
- PSAPs shall provide access to services for individuals who do not speak or understand the English language;
- PSAPs shall have sufficient call takers and equipment to consistently answer incoming calls on a daily average, of 10 seconds or less;
- Within six months of hiring a Public Safety Answering Point call taker, a county shall train the new call taker using a curriculum adopted or approved by the Board;
- A county shall provide a public safety answering point call taker with yearly in-service training using a curriculum adopted or approved by the Board; and
- In requesting funding from the Board, the county shall ensure that the county's procurement laws and policies are followed.

**COMAR is sufficient in its current content to be responsive to the needs of Maryland's 9-1-1 community and no further changes are recommended.**

## ***HISTORY OF 9-1-1 IN MARYLAND***

---

In the early 1970s the Federal Law Enforcement Assistance Administration provided funding to a number of local jurisdictions to implement 9-1-1. Charles County was the first in 1972 followed by Prince George's in 1973 and Montgomery in 1974.

1979 - Maryland became the second state in the nation to adopt 9-1-1 as the universal number for emergency services access. Since that time, it has become a household icon for public safety access and information.

The standards of the emergency communications industry required a 24-hour answering service. Automatic number information (ANI) and automatic location information (ALI), which display caller number and location information respectively, were on the drawing board. This automatic information was designed to streamline the information gathering/dispatch processes of 9-1-1 and allow the location of persons unable to identify their location or to verbally communicate.

1980 - The ENSB published Local Government Planning Guidelines for 9-1-1 Systems followed by a series of planning and implementation meetings with PSAP directors.

Ten Cent phone bill surcharge is established to fund development.

1983 - The Statute enabling the ENSB was amended to include authority for Counties to charge a fee via monthly phone bills to offset operational expenses.

1995 - All counties were required to have enhanced systems in place, i.e. city style addresses vs. route and box numbers and ANI and ALI capability. County authority to extend fee to wireless providers was granted.

The ENSB was expanded to include a member of the wireless community

1996 - FCC regulation including milestones for ANI and ALI for the wireless industry was published. Wireless Phase I with ANI displayed to the 9-1-1 call taker was to be complete by April 1, 1998 and Wireless Phase II with ALI displayed wireless call identification was to be in place by October 1, 2001.

1998 - The Training Sub-committee developed a standardized 40-hour entrance level training course for 9-1-1 dispatchers. Twenty-five trainers and seven regional coordinators were identified to disseminate the curriculum.

2000 - Legislative initiative re-drafting Article 41 – sent to summer study.

- 2001 - University of Maryland conducted study of 9-1-1 and provides administrator for coordination and evaluation. Evaluation attests to health of system but need for enhancements.
- 2002 - Anne Arundel County, selected as the State's test site for enhanced wireless service, becomes Wireless Phase I operational (call back number displayed).
- 2003 - HB 780 increased the 10-cent fee to 25 cents per bill per month. County fee authority increased from a maximum of 50 cents per bill per month to 75 cents. Board membership increased to 15 by adding representatives from the Maryland Emergency Number Association, a large county (population > 200,000), and a small county (population < 200,000) and deleting a public at large position.

Anne Arundel County becomes the first Wireless Phase II operational jurisdiction (wireless callers location displayed at the call taking station) 22 of 24 jurisdictions become Phase I operational and three Phase II operational.

- 2004 - All of Maryland becomes Wireless Phase I operational and 15 of 24 jurisdictions become Wireless Phase II operational. For the first time in most jurisdictions, more than 50% of all 9-1-1 calls originated from wireless callers.

Each of Maryland's PSAPs identified 10-digit phone numbers to enable Internet "phone" service providers (VoIP) to connect their subscribers to a PSAP when 9-1-1 is dialed to receive emergency service.

The Training Sub-committee adopted the National Academy of Emergency Dispatch's "Emergency Telecommunicator Course" as the standard for entry-level training, replacing the previously "in-house" developed training program.

Pilot Project implemented in four Eastern Shore Counties (Caroline, Dorchester, Queen Anne's, and Talbot) to examine the value and best practices of implementing police and fire dispatch protocols established by the National Academy of Emergency Dispatch.

- 2005 - All of Maryland's primary PSAPs become Wireless Phase II operational, making Maryland, according to the National Emergency Number Association, only the eighth state overall and the second most populous to accomplish this milestone.

VoIP service providers, under FCC mandate to provide E9-1-1 service by November 2005, began successful PSAP testing of routing Internet based calls (with enhanced caller information) to the appropriate primary PSAP.

Baltimore was the host to the 2005 “Navigator” Conference sponsored by the National Academy of Emergency Dispatch. The weeklong conference, held in Baltimore’s Inner Harbor, provided a venue for training opportunities and information sharing for 9-1-1 professionals from around the country. The Board also conducted a seminar detailing the experiences by four Maryland counties implementing emergency police and fire dispatch protocols system.

The process for the electronic submission of funding requests was completed and integrated into a secure link from the ENSB website. Board members now have Internet access to all project funding requests, facilitating the review and approval process.

2006 - VoIP Service Providers began routing their 9-1-1 calls through the Verizon selective router and 9-1-1 trunks to the appropriate PSAP presenting the call taker with the callback number and location of the caller (I2 solution).

Maryland establishes the Telecommunicator Emergency Response Taskforce (TERT) program to assist PSAPs cope with the demands of a natural or manmade disaster. PSAP administrators and potential TERT team members were identified and trained under the National Emergency Number Association’s national TERT initiative program.

The Board submitted a report to the Legislature detailing the feasibility and possible time-line for implementing a next generation 9-1-1 system (NG 9-1-1) using an Internet Protocol (IP) backbone to deliver voice, data, text, and video messaging to a 9-1-1 Center.

2007 - The Board worked in cooperation with the Maryland State Highway Administration to obtain statewide aerial-photography to assist Maryland counties in updating and maintaining the accuracy of their mapping capacity.

The Board worked with the Maryland State Police (MSP) to develop a RFP to explore “Next Generation” 9-1-1 Systems technologies for the development of a 9-1-1 Public Safety Network for transferring emergency calls.

The Board submitted a report to the Maryland Legislature detailing the State of the 9-1-1 Trust Fund. Funding levels were adequate for current anticipated expenditures.

2008 - The Board established “back-up” PSAP criteria, should the primary PSAP not be able fulfill its role because of power outages, telephone system interruptions, building evacuations or other natural or manmade disasters. Inspections were conducted of each jurisdiction’s back-up facility and evacuation plan.

All Maryland primary PSAPs utilize emergency medical dispatch protocols, while 60% of primary PSAPs use either emergency fire and or police dispatch protocols. Emergency protocol systems provide a standardized means to consistently query and process information from 9-1-1 callers. According to the National Academy of Emergency Dispatch, Maryland is the nationwide leader in PSAP protocol usage.

Board membership increased to 17 members, adding representation from the Geographic Information Services (GIS) community and an additional representative from Emergency Management Services.

## ***BOARD MEMBERSHIP***

---

The membership of the ENSB includes a diverse and technically astute group of professionals from the emergency services, the communications and public safety industries, as well as the public at large. The members serve a Governor appointed Senate confirmed, four-year term. While only required to meet quarterly, the ENSB has met at least monthly to examine current trends and needs of the twenty-four Public Safety Answering Points, hereafter called PSAPs.

The Board has enjoyed the support of the Department of Public Safety and Correctional Services (DPSCS) fiscal offices in providing auditing and accounting support. In recognition of time demands, the ENSB through DPSCS has employed a full time fiscal coordinator and contractual accountant to support the ENSB's efforts in administering the 9-1-1 Trust Fund.

The Board recognizes the need for entrance and in-service level training for dispatchers and supervisors. The Department established an administrative assistant position, working directly for the Office of the Executive Director, to advance the training efforts described in COMAR and handling special projects as assigned.

The wisdom of the 1979 General Assembly is evident in the diversity of stakeholders who make up the Board. It has been the practice of the appointing authority to seek diversity in the membership and Maryland is well represented. The following page outlines Board membership and the organization each member represents.



**DEPARTMENT OF PUBLIC SAFETY AND CORRECTIONAL SERVICES**

**Emergency Number Systems Board**

**Board Member Listings**

<b>Term</b>	<b>Represent</b>	<b>Member Name</b>
8/30/99 - 6/30/12	Public Service Commission	Anthony Myers
4/1/08 - 6/30/11	MIEMSS	Richard Berg
7/1/04 - 6/30/12	Volunteer Fire Service	Brian C. Ebling
7/1/05 - 6/30/09	Career Fire Service	David H. Balthis
3/15/96 - 6/30/11	Public-At-Large	William H. Walton
7/1/98 - 6/30/10	Emergency Management Systems	W. Edward Mullikin
4/1/08 - 6/30/11	Telephone Utility	Kevin M. Green
10/1/08 - 6/30/09	APCO <sup>1</sup>	Susan E. Greentree
7/1/06 - 6/30/09	Maryland State Police	Lt. Col. Robert J. McGainey
7/1/02 - 6/30/10	Police Services	Captain Charles Summers
7/1/04 - 6/30/12	Public-At-Large	Roderick W. Hart
12/29/03 - 6/30/09	Large County	Andrew M. Johnston
7/1/04 - 6/30/09	Wireless Industry	Jim Nixon
11/10/03 - 6/30/10	Small County	Steve Marshall
4/1/08 - 6/30/11	NENA <sup>2</sup> – Local Chapter	William A. Frazier
10/1/08 - 6/30/12	Emergency Management Systems	John E. Markey
10/1/08 - 6/30/12	Geographic Informational Systems	Ken Miller

1 – Association of Public-Safety Communications Officials

2 – National Emergency Number Association

## ***TYPES OF 9-1-1 SYSTEMS***

---

In the late 1980s, Maryland PSAPs achieved “enhanced” capability, successfully enabling each to display Automatic Number Information (ANI) and Automatic Location Information (ALI) for wireline 9-1-1 calls. This capability met the requirements of the Maryland Annotated Code, which was authored prior to widespread availability of wireless phones.

The advent and proliferation of wireless communications caused the public safety community to demand the same ‘enhanced’ capacity as their wireline counterparts. The Federal Communications Commission required the wireless industry, by regulation, to provide the ANI and ALI of a wireless caller to the PSAP. Today, the wireless industry is in compliance with the FCC regulations and has been able to provide enhanced wireless service to technologically capable PSAPs. In June 2005, Maryland became only the eighth state in the nation to have all primary PSAP’s (24) receive and display the ANI and ALI information from wireless 9-1-1 calls.

During 2008, the Board continued to approve project funding to upgrade various PSAP phone systems and mapping capacity to receive and display enhanced wireless data. The caller location information (ALI) provided through enhanced wireless service is received at the PSAP in measurements of latitude and longitude. Mapping of this information is required to facilitate meaningful application in processing the 9-1-1 call. The Board, in cooperation with the State Highway Administration, entered into a partnership to obtain statewide aerial-photography to assist Maryland counties to update and maintain the accuracy of their mapping capacity. This cooperative effort to obtain current statewide aerial-photography is anticipated to be an ongoing project.

In coordination with the Board, Voice over Internet Protocol (VoIP) and Telematics emergency 9-1-1 services are now being directed through the Verizon selective router to the appropriate PSAP in the same fashion as traditional communication services with caller related emergency information displayed to the call taker. Previously, these services were directed to a PSAP specific ten-digit phone number, which was outside of the 9-1-1 system.

The Board is currently examining the feasibility of migrating to an IP network based 9-1-1 system for receiving voice, data, text, and video messaging. As a pilot-project, the Board is working with the Maryland State Police (MSP) to develop a RFP to explore “Next Generation” 9-1-1 Systems technologies for the development of a 9-1-1 Public Safety Network for transferring emergency calls. The Next Generation 9-1-1 System is examined further later in this report.

## Maryland 2008 PSAP Statistics\*

County	Director	9-1-1 Calls
Allegany	Richard DeVore	40,068
Anne Arundel	Lt. Jeff Silverman	359,643
Baltimore City	Major Scott Roper	1,252,204
Baltimore	Marie Whisonant	644,051
Calvert	Jackie Vaughan	41,087
Caroline	Bryan Ebling	15,654
Carroll	Randy Waesche	61,140
Cecil	Richard Brooks	193,302
Charles	Tony Rose	67,397
Dorchester	Vernon Hurley	19,793
Frederick	Chip Jewel	109,111
Garrett	Jon Bradley Frantz	14,047
Harford	Ross Coates	101,959
Howard	Lt. Brook Donovan	276,030
Kent	Wayne Darrell	13,149
Montgomery	Brian Melby	551,281
Prince George's	Charlynn Flaherty	1,145,362
Queen Anne's	John Chew	24,773
Somerset	Steve Marshall	15,300
St. Mary's	Tom Mattingly	44,994
Talbot	W. Edward Mullikin	18,721
Washington	Bardona Woods	74,956
Wicomico	Sandy Silvia	49,347
Worcester	Teresa Owens	41,439

**Maryland Total 9-1-1 Calls:     5,174,808**

\* As reported by each County's PSAP Director

## ***FUNDING***

---

The Maryland Public Safety Article (§1-310 & §1-311) establishes two funding streams to support 9-1-1. The first is the State “9-1-1 Fee”, which is \$0.25 per subscriber per month. The second is the County “Additional Fee” in an amount determined by each county, through local ordinance, up to maximum of \$0.75 per bill per month. All Maryland counties and Baltimore City currently have passed local ordinances establishing the “Additional Fee” at \$0.75. Telephone companies, wireless carriers, and other 9-1-1 accessible service providers, collect and remit both portions of the 9-1-1 Surcharge to the State Comptroller, monthly, for deposit into the 9-1-1 Trust Fund. The total amount of 9-1-1 fees remitted to Maryland in calendar year 2008 is \$57,176,923.16.

Quarterly, the County “Additional Fee” portion is distributed to each county prorated in accordance with the level of fees collected in each jurisdiction (*Public Safety Article §1-309*). Annually, the Secretary of the Department of Public Safety and Correctional Services requests a budget appropriation from the 9-1-1 Trust Fund in an amount sufficient to carry out the purposes of the enabling legislation, pay administrative costs, and reimburse counties for the cost of enhancing their 9-1-1 system (*Public Safety Article §1-309*). Through this budget appropriation process, the State “9-1-1 Fee” is distributed from the 9-1-1 Trust Fund to the Maryland counties at the discretion of the Emergency Number Systems Board in response to county 9-1-1 enhancement requests.

Maryland has established written criteria identifying the allowable uses of funds collected. Money collected from the State “9-1-1 Fee” may be used to reimburse counties for the cost of enhancing Maryland’s 9-1-1 system through payment to a third party contractor (*Public Safety Article §1-308*). COMAR (12.11.03.12) further defines equipment qualifying for funding or reimbursement. Money distributed quarterly to the counties from the collection of the County “Additional Fee” may be spent on the installation, enhancement, maintenance, and operation of a county or multi-county 9-1-1 system. Maintenance and operation costs may include telephone company charges, equipment costs, equipment lease charges, repairs, utilities, personnel costs, and appropriate carryover costs from previous years (*Public Safety Article §1-312*).

The following chart indicates the 9-1-1 Surcharge fees associated with each jurisdiction and the date of resolution modifying the county additional fee.

### Maryland 9-1-1 Surcharge Fees

County	State Fee	County Fee	Effective Date
Allegany	\$0.25	\$0.75	October 1, 2003
Anne Arundel	\$0.25	\$0.75	July 1, 2005
Baltimore City	\$0.25	\$0.75	June 23, 2004
Baltimore	\$0.25	\$0.75	April 23, 2004
Calvert	\$0.25	\$0.75	June 15, 2004
Caroline	\$0.25	\$0.75	November 9, 2004
Carroll	\$0.25	\$0.75	June 8, 2004
Cecil	\$0.25	\$0.75	October 1, 2003
Charles	\$0.25	\$0.75	January 1, 2004
Dorchester	\$0.25	\$0.75	October 1, 2003
Frederick	\$0.25	\$0.75	July 1, 2004
Garrett	\$0.25	\$0.75	October 1, 2003
Harford	\$0.25	\$0.75	May 4, 2004
Howard	\$0.25	\$0.75	July 1, 2007
Kent	\$0.25	\$0.75	January 30, 2004
Montgomery	\$0.25	\$0.75	October 1, 2003
Prince George's	\$0.25	\$0.75	March 5, 2004
Queen Anne's	\$0.25	\$0.75	October 1, 2003
Somerset	\$0.25	\$0.75	February 10, 2004
St. Mary's	\$0.25	\$0.75	July 1, 2004
Talbot	\$0.25	\$0.75	May 11, 2004
Washington	\$0.25	\$0.75	October 21, 2003
Wicomico	\$0.25	\$0.75	January 1, 2004
Worcester	\$0.25	\$0.75	October 1, 2003

The chart below reflects the Fiscal Year 2008 distribution of the collected “additional charge” fees.

### FY 2008 “Additional Fee” Payments to the Jurisdictions

<i>County</i>	<b>Population*</b>	<b>FY 08 Disbursement</b>
<b>Allegany County</b>	<b>72,594</b>	<b>\$495,819.70</b>
<b>Anne Arundel County</b>	<b>512,154</b>	<b>\$4,124,540.74</b>
<b>Baltimore City</b>	<b>631,366</b>	<b>\$4,977,998.13</b>
<b>Baltimore County</b>	<b>788,994</b>	<b>\$5,799,536.46</b>
<b>Calvert County</b>	<b>88,223</b>	<b>\$618,778.35</b>
<b>Caroline County</b>	<b>32,910</b>	<b>\$202,474.15</b>
<b>Carroll County</b>	<b>169,220</b>	<b>\$1,160,269.96</b>
<b>Cecil County</b>	<b>99,695</b>	<b>\$653,682.60</b>
<b>Charles County</b>	<b>140,444</b>	<b>\$1,025,901.20</b>
<b>Dorchester County</b>	<b>31,846</b>	<b>\$233,364.78</b>
<b>Frederick County</b>	<b>224,705</b>	<b>\$1,638,759.03</b>
<b>Garrett County</b>	<b>29,627</b>	<b>\$257,869.37</b>
<b>Harford County</b>	<b>239,993</b>	<b>\$1,654,342.51</b>
<b>Howard County</b>	<b>273,669</b>	<b>\$2,073,537.26</b>
<b>Kent County</b>	<b>19,987</b>	<b>\$160,327.50</b>
<b>Montgomery County</b>	<b>930,813</b>	<b>\$7,561,191.70</b>
<b>Prince George's County</b>	<b>828,770</b>	<b>\$6,461,619.06</b>
<b>Queen Anne's County</b>	<b>46,571</b>	<b>\$327,239.72</b>
<b>Somerset County</b>	<b>26,016</b>	<b>\$130,706.96</b>
<b>St Mary's County</b>	<b>100,378</b>	<b>\$628,974.26</b>
<b>Talbot County</b>	<b>36,193</b>	<b>\$324,101.03</b>
<b>Washington County</b>	<b>145,113</b>	<b>\$957,429.99</b>
<b>Wicomico County</b>	<b>93,600</b>	<b>\$640,444.10</b>
<b>Worcester County</b>	<b>49,374</b>	<b>\$516,282.75</b>
<b>TOTALS</b>	<b>5,612,255</b>	<b>\$42,625,191.31</b>

\* 2007 Projected Population Estimates (Maryland Manual)

## ***ENSB EXPENDITURES***

---

The Department of Public Safety and Correctional Services annual budget for the Emergency Number Systems Board is \$13.55 M. The budget rose from \$5.3 M in October 2003, when legislation increased the State portion of the 9-1-1 Surcharge to \$0.25. Supplemental budget increases were requested in FY 07 and FY 08 in response to expenditures for essential 9-1-1 phone equipment upgrades.

The technical nature of 9-1-1 communications has evolved over time to include the advent of computer-aided dispatch, multiple agencies providing emergency response, national standard setting organizations, wireless telephone communications, and most recently, IP based communication services. These have brought about fundamental changes in the 9-1-1 infrastructure and added personnel and equipment challenges.

Over the last three fiscal years, the vast majority of funds were allocated to upgrading phone systems, to keep current with technological advances, and enhancing mapping capacity. All Maryland PSAPs now have the capability of mapping the position of 9-1-1 callers, when location information is received by the call taker. In order to maintain current maps, the Board entered into a cooperative effort with the Maryland State Highway Administration, to assist with funding statewide orthophotography to be procured and shared with all Maryland PSAPs for enhanced emergency caller location capacity. It is anticipated that this will be an ongoing funding effort to assist Maryland develop, maintain, and further efforts to establish mapping standards, quality, and functionality leading to universal ownership of the resulting statewide mapping product.

The charts below reflect Board expenditures over the previous three fiscal years.

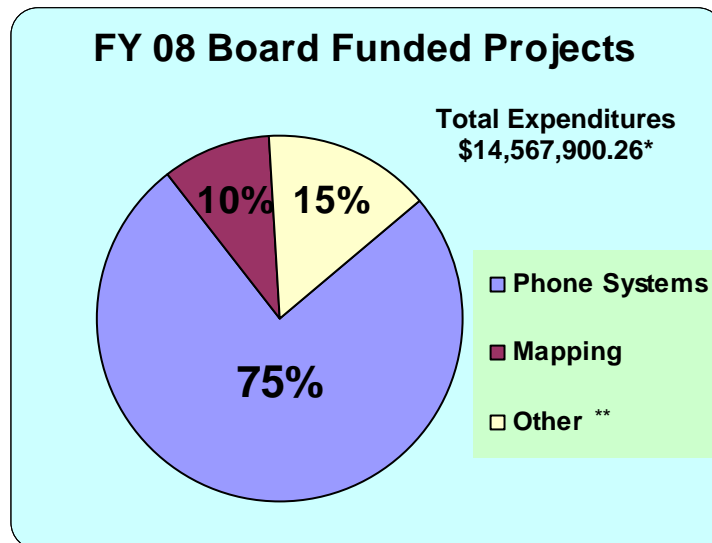
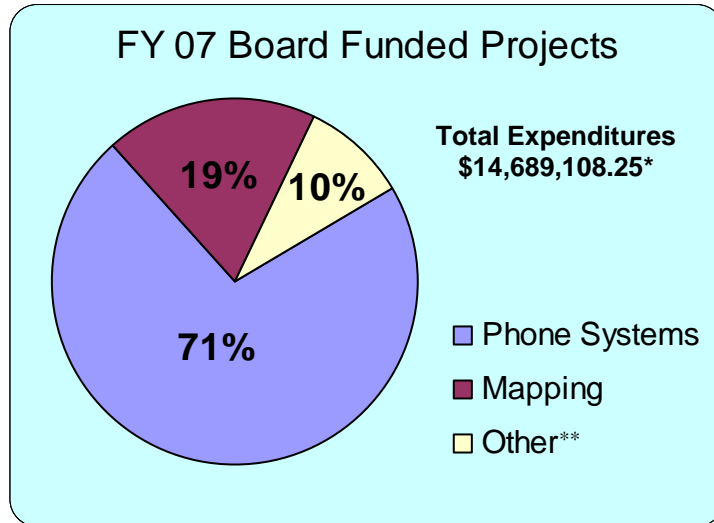
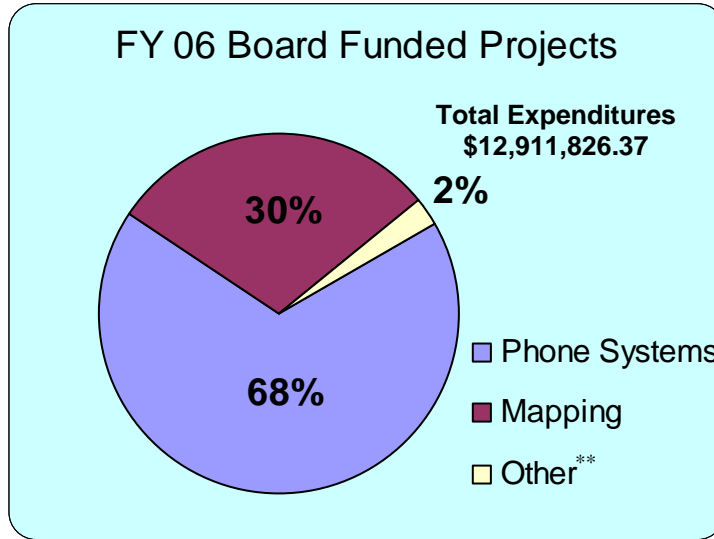

\* Additional funding obtained from Trust Fund    \*\* see following page for "Other" expenditures description



**\*\* Other Funding:**

“Other” funding is comprised of capital expenditures related to 9-1-1 call processing or its enhancement. Some examples of these capital expenditures are listed below:

- 9-1-1 Center security;
- Back-up power systems;
- Redundant/diverse 9-1-1 call routing;
- Training – entry-level, in-service and supervisory/administrative;
- Lightning/surge protection; and
- Protocol call processing systems

## ***COUNTY AUDITS***

---

The Public Safety Article requires each county to annually report to the Board how the monies received from the trust fund were spent. The Board is charged with the responsibility of evaluating the expenditures for compliance with applicable laws and regulations. To this end, the Board funds independent audits of county expenditures.

All of the audits for FY 08 were received and auditors compensated. The audits were reviewed and each county found in compliance with the spending limits articulated in the Public Safety Article.

## ***MANAGING FOR RESULTS***

---

Maryland's Managing for Results (MFR) initiative requires the identification of an organizational mission accompanied by specified goals and performance measures. This is incorporated in the Department's Strategic Plan. The Emergency Number Systems Board established two Managing for Results (MFR) objectives that would track the quality and consistency of the emergency response information extracted from 9-1-1 callers by Emergency Number Operators (call takers) staffing Maryland's twenty-four (24) Public Safety Answering Points.

Formerly, PSAPs in Maryland rely solely on the training and experience of the call taker to process a 9-1-1 call. Police and fire protocol systems have been established by national organizations to provide a standard means to query 9-1-1 callers to elicit the information required to properly respond to an emergency call. The response made by the 9-1-1 caller to initial questions identify subsequent questions needed to guide the Emergency Number Operator in appropriately processing the emergency call and providing the 9-1-1 caller with suitable pre-arrival instructions. The utilization of nationally established protocols for processing 9-1-1 calls will enhance consistency of 9-1-1 call handling.

**Goal**    **To meet compliance standards for emergency number operator use of nationally established emergency processing protocols in Maryland to extract optimum information for improved emergency response.**

**Objective 1.1** – By June 2009, at least 80% of the 9-1-1 Centers (Public Safety Answering Points) will utilize nationally established police and/or fire emergency protocol systems for emergency number operators to process 9-1-1 calls.

**Performance:** Objective 1.1 was designed to target the “use” (implementation) of police and fire protocol systems, and Objective 1.2 was designed to target subsequent compliance with protocol standards after implementation. During fiscal year 2008, ENSB funded an additional four PSAP (county) requests to implement protocol systems. With 15 PSAPs implementing these protocol systems, the target of 60% was exceeded, and the target of 80% (or 19 PSAPs) for fiscal year 2009 is expected to be achieved.

**Objective 1.2** – By June 2009, at least 80% of those 9-1-1 Centers (Public Safety Answering Points) that utilize nationally established police and/or fire emergency protocol systems for emergency number operators to process 9-1-1 calls will achieve at least a 90 % standards compliance rate.

**Performance:** ENSB's protocol funding policy requires implementation of protocol systems be accompanied by the implementation of their associated quality assurance (standards) program, which requires a careful review of the

“processing of 9-1-1 calls” handled by each Emergency Number Operator to determine the percentage of protocol compliance for each PSAP. In fiscal year 2008, eight of the ten PSAPS using the protocol systems and report compliance scores, have consistently exceeded the 90% compliance standard.

Maryland’s statewide utilization of nationally established protocols for processing 9-1-1 calls, to ensure consistency of 9-1-1 call handling in any PSAP and thus to measurably improve public safety, must be tracked by how well the PSAPs comply with the protocols. Objective 1.1 will track the “use” (implementation) of these protocols; this objective (1.2) will track the compliance with the protocols. Police and fire protocol systems utilize a quality assurance checklist to review actions taken by Emergency Number Operators to determine the percent of protocol compliance. All Emergency Number Operators that have completed protocol training will be subject to quality assurance review.

“Police and fire protocols” are two sets of standardized “question and answer” systems that guide the Emergency Number Operator to obtain appropriate (police or fire) emergency response information and to provide pre-arrival instructions to 9-1-1 callers. The protocols can be implemented either manually employing a card-set system or be integrated into an existing computer system to be utilized in an electronic format.

**Maryland Deployment of Protocol Usage – November 2008**  
(Three additional counties have implemented since July 2008)

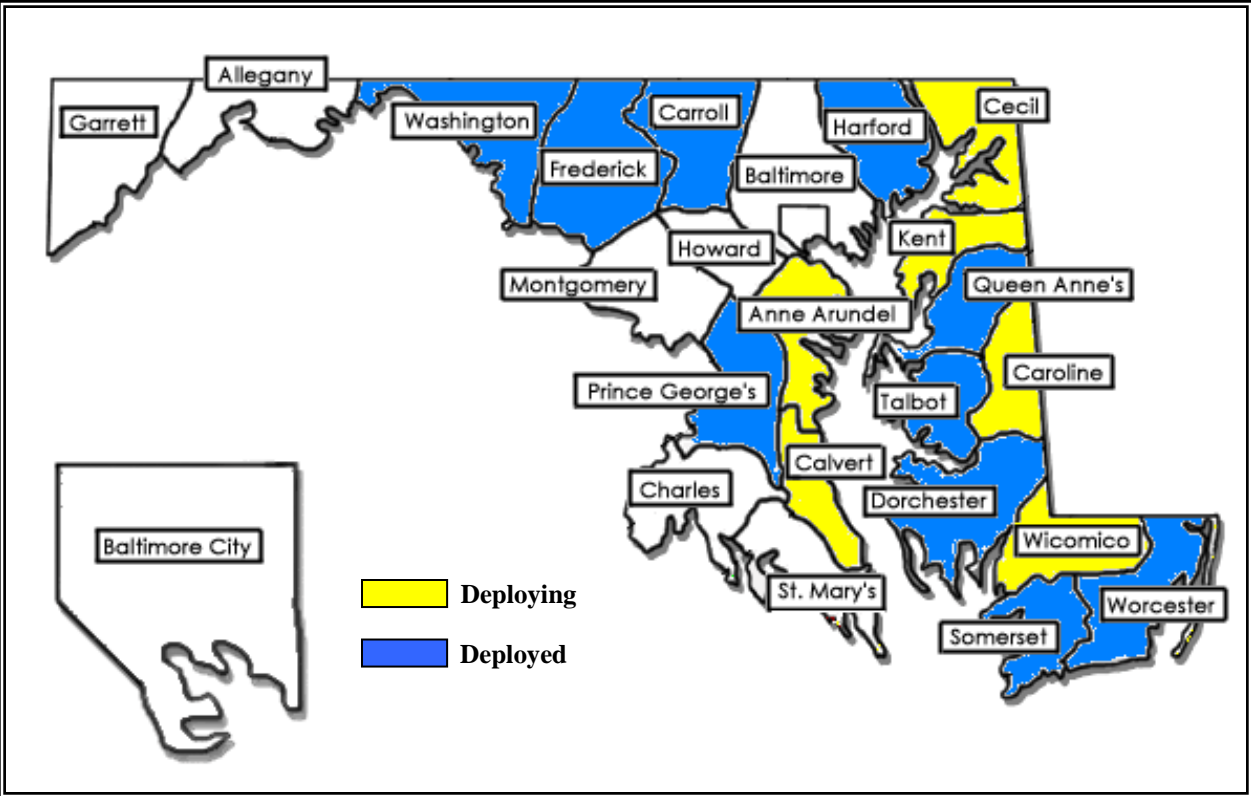

# ***MSP NEXT GENERATION 9-1-1 FEASIBILITY PROJECT***

---

The Maryland Emergency Number Systems Board and the Maryland State Police (MSP) have recognized that the potential exists for faster emergency response times and improved emergency services to the citizens of the State of Maryland. This can be accomplished by modernizing the routing and delivery of E9-1-1 calls being transferred to MSP throughout the State. To that end, the ENSB is investigating the implementation of an advanced IP-enabled network for delivery of emergency E9-1-1 traffic to the Maryland State Police barracks, known conceptually as a Next Generation E9-1-1 network solution.

IP-based systems will allow the MSP barracks and county PSAPs to work together cooperatively in ways that the current systems do not allow. An IP-based system will allow the barracks to receive more robust call-related data, directly from the PSAP, when emergency calls are transferred. Currently the E9-1-1 calls are transferred via the public switch telephone network (PSTN), from the neighboring PSAPs, without the public safety benefit of automatic number identification (ANI) or automatic location identification (ALI) being readily available. Direct connectivity to the 9-1-1 network supports receiving and updating ANI/ALI, providing real-time location information for wireline or wireless emergency callers.

In the future, multiple data sources such as telematics, text, video, and other communication mediums may also be able to be transferred from the primary PSAP to MSP utilizing this planned network. IP-based systems and equipment that can be upgraded to support communications alternatives for the hearing impaired or disabled community (i.e. text messaging, video relay services, etc.) are important enhancements to public safety.

The IP network is anticipated to be redundant and diverse, leveraging high-speed digital technologies to interconnect all MSP barracks. The network design and architecture anticipates improved call set-up time and enhanced capability to transfer E9-1-1 calls between all barracks in the state of Maryland. The neighboring PSAPs will continue to support all primary E9-1-1 traffic in the existing manner.

**The Board engaged a consultant, L Robert Kimball and Associates, to study the anticipated costs of a Next Generation 9-1-1 System. The Board anticipates that the capital expenditures required to establish the network, procuring the call processing equipment, and barrack workstations can be met with no increase in the state portion of the 9-1-1 Surcharge, due to the funds positive balance. Once long-term network recurring costs are determined, it may become necessary to consider increasing the county “additional fee” portion of the 9-1-1 Surcharge.**

The recurring costs associated with maintaining the proposed MSP E9-1-1 network and equipment were identified and are estimated to be substantial, possibly in the range of \$3

M per year, by L. Robert Kimball (Board consultant). The counties receive funding from the “additional fee” portion of the 9-1-1 Surcharge to offset operational costs. **Currently, there is no designated funding source available to MSP to offset recurring expenditures.**

Finally, the experience gained in developing and deploying the NG 9-1-1 network to the MSP call centers will provide valuable experience applicable to the future implementation of a statewide NG 9-1-1 public safety network. Maryland will again be poised to be a national leader in providing a 9-1-1 system that is technologically responsive to the emergency service needs of our citizens and visitors.

In fiscal year 2008, the Board and Maryland State Police continues to work cooperatively with other state agencies to further refine the MSP NG 9-1-1 project’s “request for proposal” (RFP) and to foster synergy for the implementation of a statewide public safety broadband network. Upon the recommendation of the Department of Information Technology (DoIT), a “project manager” familiar with NG 9-1-1 systems will be secured before proceeding further with this project. It will be the role of the project manger to craft the final MSP NG 9-1-1 project’s RFP, provide evaluative support in reviewing responses, assist in the selection process of the most applicable NG 9-1-1 technology and fiscally responsive vendor, and oversee the implementation of the project.

It is anticipated that in FY 09 a NG 9-1-1 systems “project manager” RFP will be released and, upon evaluation, a vendor selected.

## ***TRAINING SUBCOMMITTEE***

---

The Training Subcommittee is comprised of members of the Board and the PSAP community, chaired by the Caroline County PSAP Director and ENSB member, Bryan Ebling. In order to provide Maryland with a robust training program with the applicable content, the Training Subcommittee reviewed numerous training opportunities, programs, and seminars before deciding which programs to offer for the 2008 training sessions.

<b>ENSB Training Subcommittee</b>
<b><u>Chairman</u></b> Bryan Ebling – Caroline County
John Crabill – ENSB
Howard “Buddy” Redman – Training Coordinator
Mitch Vocke – Harford County
Lt. Col. Robert J. McGainey – Maryland State Police
Randy Waesche – Carroll County
Roy Lescalleet – Washington County
John “Chris” McNamara – Howard County

The Code of Maryland Regulations (COMAR) provides specific guidance on the topical requirements for training but does not address job relatedness, testing standards, or instructional methodologies for new, in-service, or supervisory employees. The Board, through the recommendation of the Training Subcommittee, partnered with the National Academy of Emergency Dispatch (NAED) to provide an Emergency Telecommunicator Course (ETC) to instruct Maryland’s newly hired 9-1-1 call takers. This course provides a comprehensive review of the skills and abilities needed for successful handling of 9-1-1 emergency calls and is presented utilizing curriculum designed for adult based learning. Trainers from each PSAP attended NAED sponsored classes and earned ETC Instructor certification. During 2008 an additional 30 instructors were certified, increasing and maintaining the number of jurisdictions having an in-house ETC Instructor. In addition, over 175 new 9-1-1 call takers successfully completed the ETC entry-level training. For additional information of the program, the web address for the National Academy is <http://www.naemd.org/>.

Several of this year’s training programs utilized the facilities of the Public Safety Training Center, located in Sykesville, Maryland. The facility, which is centrally located, provides a rich learning environment with state of the art technology and ample classrooms able to accommodate up to 75 students.

The Training Subcommittee reviewed numerous training programs recommended by our 9-1-1 Centers. Course selections were made and offered during either a spring or fall timeframe, to best accommodate employee scheduling. Training programs were typically provided at least twice, once on the Eastern Shore and once in the central to western part of the state.

The Emergency Number Systems Board has supported a variety of training programs and encourages the use of protocol systems throughout Maryland. Sixty percent of the jurisdictions are currently using either Emergency Fire or Emergency Police Dispatch, in addition to Emergency Medical Dispatch protocols. In support of this effort, various protocol classes and protocol Quality Assurance training have been presented around the State.



Quality Assurance Training in Kent County

## **Fiscal Year 2008 Training Programs**

### **Spring Session**

#### **Suicide Intervention and Family Violence**

**16 Attendees**

9-1-1 Centers are often the first “first responder” when hostage events or barricaded suspect events occur. Call takers must know the delicate balance that they are responsible for during family emergency and various crisis calls. Improved communications skills are developed to aid the call taker in their vital role of information gathering.

#### **FIRE**

**16 Attendees**

Call takers new to fire communications will a variety of great knowledge nuggets in this workshop. What are the best questions to ask in a fire emergency? How do you balance a quick response with your best customer service skills? Included in this course is a review of the Incident Command System.

#### **Under The Headset: Surviving Dispatch Stress**

**28 Attendees**

A program designed to help the call taker recognize and understand the stress that impacts the profession. Cumulative, occupational, and critical incident stress are discussed. Coping techniques are introduced and demonstrated. Students learn the skills to facilitate the recovery process after work related stressors.



**School Violence: Lessons Learned****71 Attendees**

This class takes an in-depth look at School Violence. Discussions include the profile of a school violence suspect, pre-planning strategies for handling school violence events, and how progressive agencies prepare to handle these events.

**Customer Service the 9-1-1 Way****103 Attendees**

Participants discuss who their customers are at their agency and in their community. Instructors demonstrate how great customer service makes the job more efficient, saving unnecessary responses and improving the image of their agency. Students gain the tools to provide excellent quality service.

**Surviving in the Communications Center Environment****24 Attendees**

This program focuses on the critical role of the call taker in public safety. Students benefit in improved interpersonal and leadership skills, being a team player, enhanced training methods, and overall personal development.

**Emergency Telecommunicator Class – Instructor****30 Attendees**

Students receive instructor certification and review the Emergency Telecommunicator Course (ETC) program in preparation for teaching in their local jurisdiction. This course provides the student with the skills and knowledge to teach newly hired staff in their PSAP. This program was offered twice during the year in an effort to meet the needs of all jurisdictions.

**Fall Session****Missing and Exploited Children – Administrators****17 Attendees**

Maryland was part of a pilot project for the National Center for Missing and Exploited Children. In the past we have had several presentations concerning the issues and a nationwide approach to receiving calls for Missing and Exploited Children. The course will focus on what the administrator needs to know to implement protocols for dealing with these type of calls.

**Missing and Exploited Children – Train the Trainer****38 Attendees**

This course will discuss the American National Standards Institute (ANSI) standards and what each jurisdiction will need to do to implement this program. Protocols will be reviewed for handling calls for Missing and Exploited Children. Jurisdictions currently using protocol systems for call taking will also learn of the steps taken to comply with these ANSI standards.

**Communications Training Officer Course****41 Attendees**

The course focuses on the essential elements of a one-on-one training program. Topics include the roles and responsibilities of a trainer, adult learning styles, documentation, and counseling techniques.

**Trains, Planes, and Automobiles****41 Attendees**

Transportation emergency response from the initial 9-1-1 call to response and recovery is covered in this program. Skills and techniques for call taking through progressive coordination of transportation emergencies will be discussed.

**Overcoming Negativity in the 9-1-1 Center****60 Attendees**

This course delves into the fears, concerns, and lack of control issues that haunt the 9-1-1 Center. Overcoming Negativity provides the tools need and the principals apply to your 9-1-1 life as well as your personal life. Students can now define negativity and identify the characteristics and differences between optimists, pessimists, and realists. Students learn how to keep a positive attitude.

**Progressive Supervision Workshop****54 Attendees**

This class is 70% lecture and 30% practical exercise or class interaction. Topics included in the day's activity will cover; writing effective evaluations, work style recognition, recruiting and retaining employees, rewarding excellence, managing difficult personalities, and the human side of 9-1-1.

## ***POLICY SUBCOMMITTEE***

---

The Policy Subcommittee is tasked with developing the policy and procedures to provide guidance to the Board and PSAPs with regard to requesting and encumbering funding from the 9-1-1 Trust Fund. They also craft and respond to recommendations for legislative changes affecting the Public Safety Article and the Code of Maryland Regulations (COMAR) as it relates to 9-1-1 service.

<b>Policy/Legislative Subcommittee</b>
<b><u>Chairman</u></b> Kevin Green
Ed Mullikin - ENSB
Anthony Myers - ENSB
Charles Summers - ENSB
Andrew Johnston - ENSB
Jim Nixon - ENSB
John Crabill - NENA
Ray Windisch – Baltimore County
John Chew – Queen Anne’s County

During fiscal year 2008, the Policy Subcommittee recommended and the Board adopted updates to the Board’s definitions and requirements for Primary, Secondary, and Back-Up PSAPs. Technological enhancements to the 9-1-1 system and Homeland Security concerns were the impetus for recommending these changes. The Board, in cooperation with the PSAPs, is working diligently to provide direction and funding to effect compliance with these new guidelines.

## ***TECHNOLOGY SUBCOMMITTEE***

**SCOPE/GOAL:** The Technology Subcommittee is responsible for the investigation, and research of technology related issues and the dissemination of technical information to the membership of the ENSB. This subcommittee will be focused on issues that could impact the management, operation, and maintenance of E9-1-1 systems serving the citizens of the State of Maryland.

**DIRECTION:** Develop and disseminate briefing materials in the areas of Data Systems, Communication Networks, Public Safety Answering Point Power Systems, and Telephone Station Equipment technologies that could be of value to the ENSB in the fulfillment of its responsibilities.

<b>Technology Subcommittee</b>
<b><u>Chairman</u></b> Rod Hart - ENSB
John Crabill - NENA
Dave Balthis - ENSB
Jim Nixon - ENSB
Steve Marshall - ENSB
Charles Summers - ENSB
Lt. Col. Robert McGahey - ENSB
Andy Johnston - ENSB
Ed Mullikin - ENSB
Cathy Kurnas – Plant/CML
Ray Windisch – Baltimore County

The Technology Subcommittee is currently reviewing the feasibility of implementing a Next Generation 9-1-1 System (NG 9-1-1) in Maryland. Working in conjunction with the Board's consultant and monitoring activities of national organizations, the Technology Subcommittee is following NG 9-1-1 technological advancements and establishment of industry standards/regulations to better prepare and inform the Board as to NG 9-1-1 implementation options. The Technology Subcommittee assisted in the development, technical review, and is currently monitoring the release of the MSP NG 9-1-1 Network RFP.

The Technology Subcommittee also examined the technical capabilities and effectiveness of utilizing a Network Control Modem (NCM) for Maryland PSAPs to quickly and

securely transfer 9-1-1 call traffic to an alternate 9-1-1 answering point. Security of the network is maintained by use of user-specified password protection and an optional dial-back number. Users may interface with the system through a standard touch-tone phone for entering passwords and commands. Voice commands are used to lead the user through necessary processes and to provide status reports. When a transfer of calls is completed the NCM will remain connected to the transferred location until new commands are sent.

A NCM Alarm Unit may also be connected in the system. This unit resides at the PSAP and provides the ability to manually transfer calls to an alternate location. In addition, the NCM Alarm Unit provides an audible and visual alarm should the path fail.

The NCM would normally be installed at the 9-1-1 Tandem Office and provides a method to transfer calls to an alternate location in an emergency, as the below diagram demonstrates.

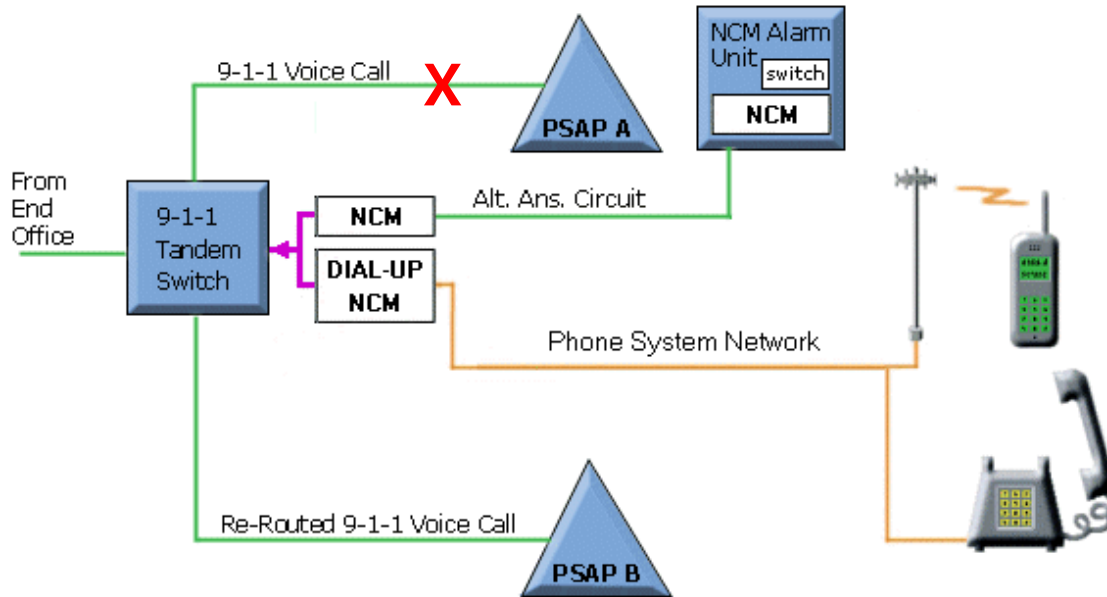

Maryland PSAPs currently have the ability to transfer 9-1-1 call traffic via a make busy switch at each of the primary PSAPs but it is believed that this new technology would improve and better secure that process.

# ***STANDARDS SUBCOMMITTEE***

## **STANDARDS SUBCOMMITTEE MISSION STATEMENT**

The subcommittee's mission is to develop guidelines to be used by the Board in its consideration of 911 equipment and service purchases. The Standards Subcommittee is responsible for the investigation, research, and development of technical, operational, procurement, and replacement standards for 911 equipment and service purchases.

## **STRATEGIES**

- Develop written guidelines to be used by the ENSB in its consideration of the pricing, functionality, and quantities proposed for routine 911 equipment and service purchases.
- Develop procurement standards including equipment replacement cycles, and minimum qualifications.
- Review the standards and procurement activities of national associations and efforts of other jurisdictions/states, to adopt best practices in Maryland.
- Identify synergistic procurement opportunities in Maryland and foster the competitive bidding process.
- Develop spare/back-up equipment purchase guidelines.
- Develop statistical models to capture and reflect information relative to the Board's procurement activities and pricing trends.
- Work with the other subcommittees as needed to support the overall goals and objectives of the Board.

<b>Standards Subcommittee</b>
<b><u>Chairman</u></b> Kevin Green - ENSB
Ed Mullikin - ENSB
Tom Miller – Retired MIEMSS
William Walton - ENSB
Cathy Kurnas – Plant/CML
Pete Loewenheim – Washington Co.
Ray Windisch – Baltimore County

The Standards Subcommittee is currently working with the Policy Subcommittee in reviewing and memorializing existing Board policies and guidelines in an effort to update the ENSB Policy/Guidelines Manual.

# ***ENSB/MENA DAY OF CELEBRATION***

---

**SEPTEMBER 13, 2007**

The Emergency Number Systems Board (ENSB), in cooperation with the Maryland Emergency Number Association presented the sixth annual 9-1-1 Day of Celebration on September 17, 2008. This event is intended to recognize the dedication and professional service provided by Maryland's Telecommunicators that answer 9-1-1 calls from the citizens and visitors of our State requesting emergency services. Queen Anne's County hosted the 2007 "Day of Celebration" at the Kent Island Fire Department in Stevensville, Maryland. More than 150 Telecommunicators, supervisors, and other 9-1-1 service related personnel were welcomed to Queen Anne's County by Chris McNamara, President of the Maryland Chapter of NENA. Attendees then began the morning session with a training seminar titled "In-Progress Calls" presented by Public Safety Training Consultants (PSTC), a nationwide leader in 9-1-1 Center training. Brian Fontes, CEO of the National Emergency Number Association (NENA) presented a keynote speech.

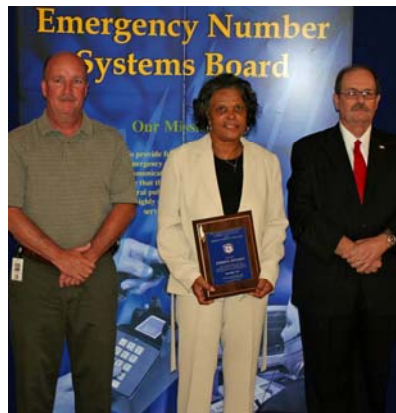

Chris McNamara (left) and William Frazier – ENSB, present the Baltimore City "Telecommunicator of the Year" award to Veronica Ragsdale

"Telecommunicator of the Year" awards were presented to exemplary Telecommunicators selected by their local 9-1-1 Center directors for outstanding service and dedication to Public Safety through 9-1-1 communications. Twenty-three of Maryland's twenty-four 9-1-1 Centers participated and those selected were presented with a plaque honoring their achievement and were acknowledged by their peers. The President of Maryland Chapter of NENA, Chris McNamara made the award presentations to the Telecommunicator of the Year recipients. Assisting in presenting these awards was William Frazier, Board member.

---

Throughout 2008, the Board and executive office fostered relationships with a number of professional organizations in support of 9-1-1. These included the National Emergency Numbers Association (NENA), the Maryland Emergency Number Association (MENA – local chapter of NENA), the Association of Public-Safety Communications Officials (APCO), the 9-1-1 Institute, and the National Association of State 9-1-1 Administrators (NASNA).

## TELECOMMUNICATOR OF THE YEAR 2008

08 Award Winner	County/City
J. Samuel Dudley	Allegany County
FF Lori Klima	Anne Arundel County
PCO II Inger Priegel	Anne Arundel County
Veronica Ragsdale	Baltimore City
Melissa Elliott	Baltimore County
ECT Dona Carter	Baltimore County
ECT I Mark Hicks	Baltimore County
Timothy E. Kane	Calvert County
Jason Davis	Caroline County
ECS II Jefferson D. Mitten	Carroll County
Vera Westerinen	Cecil County
Andrew C. Spalding	Charles County
Sheila Brittingham	Dorchester County
ECS I Diane Nichols	Frederick County
Phil Rook	Garrett County
Patricia Vincenti	Harford County
Kristen Harvey	Howard County
Rick DeBow	Howard County
Todd McGinnis	Kent County
2008 TEAM Award	Montgomery County
Farhan Qureshi	Prince George's County
James Feeney	Prince George's County
Derrick Leonard	Queen Anne's County
Daniel Dottellis	Queen Anne's County
Ronnie Lewis	Somerset County
Kelly J. Crosby	St. Mary's County
Robin Hooper	Talbot County
Nicola Venuto	Talbot County
Keith L. Bowen	Washington County
No Nominee Selected	Wicomico County
Emergency Services D-Shift	Worcester County



# STATE OF MARYLAND

## **PUBLIC SAFETY ARTICLE**

### **§ 1-301.**

(a) In this subtitle the following words have the meanings indicated.

(b) "Additional charge" means the charge imposed by a county in accordance with § 1-311 of this subtitle.

(c) "Board" means the Emergency Number Systems Board.

(d) "Commercial mobile radio service" or "CMRS" means mobile telecommunications service that is:

(1) provided for profit with the intent of receiving compensation or monetary gain;

(2) an interconnected, two-way voice service; and

(3) available to the public.

(e) "Commercial mobile radio service provider" or "CMRS provider" means a person authorized by the Federal Communications Commission to provide CMRS in the State.

(f) "County plan" means a plan for a 9-1-1 system or enhanced 9-1-1 system, or an amendment to the plan, developed by a county or several counties together under this subtitle.

(g) (1) "Customer" means:

(i) the person that contracts with a home service provider for CMRS; or

(ii) the end user of the CMRS if the end user of the CMRS is not the

contracting party.

(2) "Customer" does not include:

(i) a reseller of CMRS; or

(ii) a serving carrier under an arrangement to serve the customer outside the home service provider's licensed service area.

(h) "Enhanced 9-1-1 system" means a 9-1-1 system that provides:

(1) automatic number identification;

(2) automatic location identification; and

(3) any other technological advancements that the Board requires.

(i) "FCC order" means an order issued by the Federal Communications Commission under proceedings regarding the compatibility of enhanced 9-1-1 systems and delivery of wireless enhanced 9-1-1 service.

(j) "Home service provider" means the facilities-based carrier or reseller that contracts with a customer to provide CMRS.

(k) "9-1-1-accessible service" means telephone service or another communications service that connects an individual dialing the digits 9-1-1 to an established public safety answering point.

(l) "9-1-1 fee" means the fee imposed in accordance with § 1-310 of this subtitle.

(m) (1) "9-1-1 service carrier" means a provider of CMRS or other 9-1-1-accessible service.

(2) "9-1-1 service carrier" does not include a telephone company.

- (n) (1) "9-1-1 system" means telephone service that:
  - (i) meets the planning guidelines established under this subtitle; and
  - (ii) automatically connects an individual dialing the digits 9-1-1 to an established public safety answering point.
- (2) "9-1-1 system" includes:
  - (i) equipment for connecting and outswitching 9-1-1 calls within a telephone central office;
  - (ii) trunking facilities from a telephone central office to a public safety answering point; and
  - (iii) equipment to connect 9-1-1 calls to the appropriate public safety agency.
- (o) "9-1-1 Trust Fund" means the fund established under § 1-308 of this subtitle.
- (p) "Public safety agency" means:
  - (1) a functional division of a public agency that provides fire fighting, police, medical, or other emergency services; or
  - (2) a private entity that provides fire fighting, police, medical, or other emergency services on a voluntary basis.
- (q) "Public safety answering point" means a communications facility that:
  - (1) is operated on a 24-hour basis;
  - (2) first receives 9-1-1 calls in a 9-1-1 service area; and
  - (3) as appropriate, dispatches public safety services directly, or transfers 9-1-1 calls to appropriate public safety agencies.
- (r) "Secretary" means the Secretary of Public Safety and Correctional Services.
- (s) "Wireless enhanced 9-1-1 service" means enhanced 9-1-1 service under an FCC order.

**§ 1-302.**

- (a) The General Assembly:
  - (1) recognizes the paramount importance of the safety and well-being of the public;
  - (2) recognizes that timely and appropriate assistance must be provided when the lives or property of the public is in imminent danger;
  - (3) recognizes that emergency assistance usually is summoned by telephone, and that a multiplicity of emergency telephone numbers existed throughout the State and within each county;
  - (4) was concerned that avoidable delays in reaching appropriate emergency assistance were occurring to the jeopardy of life and property; and
  - (5) acknowledges that the three digit number, 9-1-1, is a nationally recognized and applied telephone number that may be used to summon emergency assistance and to eliminate delays caused by lack of familiarity with emergency numbers and by confusion in circumstances of crisis.
- (b) The purposes of this subtitle are to:
  - (1) establish the three digit number, 9-1-1, as the primary emergency telephone number for the State; and
  - (2) provide for the orderly installation, maintenance, and operation of 9-1-1 systems in the State.

**§ 1-303.**

(a) (1) This subtitle does not require a public service company to provide any equipment or service other than in accordance with tariffs approved by the Public Service Commission.

(2) The provision of services, the rates, and the extent of liability of a public service company are governed by the tariffs approved by the Public Service Commission.

(b) (1) This subtitle does not require a 9-1-1 service carrier to provide any equipment or service other than the equivalent of the equipment and service required of a telephone company under subsection (a) of this section.

(2) This subtitle does not extend any liability to a 9-1-1 service carrier.

**§ 1-304.**

(a) Each county shall have in operation an enhanced 9-1-1 system.

(b) If implementation is preceded by cooperative planning, the enhanced 9-1-1 system required under subsection (a) of this section may operate as part of a multicounty system.

(c) (1) Services available through a 9-1-1 system shall include police, fire fighting, and emergency ambulance services.

(2) Other emergency and civil defense services may be incorporated into the 9-1-1 system at the discretion of the county or counties served by the 9-1-1 system.

(d) (1) The digits 9-1-1 are the primary emergency telephone number in the 9-1-1 system.

(2) A public safety agency whose services are available through the 9-1-1 system:

(i) may maintain a separate secondary backup telephone number for emergency calls; and

(ii) shall maintain a separate telephone number for nonemergency calls.

(e) Educational information that relates to emergency services made available by the State or a county:

(1) shall designate the number 9-1-1 as the primary emergency telephone number; and

(2) may include a separate secondary backup telephone number for emergency calls.

(f) (1) Each public safety answering point shall notify the public safety agencies in a county 9-1-1 system of calls for assistance in the county.

(2) Written guidelines shall be developed to govern the referral of calls for assistance to the appropriate public safety agency.

(3) State, county, and local public safety agencies with concurrent jurisdiction shall have written agreements to ensure a clear understanding of which specific calls for assistance will be referred to which public safety agency.

(g) Counties, other units of local government, public safety agencies, and public safety answering points may enter into cooperative agreements for the allocation of maintenance, operational, and capital costs attributable to the 9-1-1 system.

**§1-305.**

(a) There is an Emergency Number Systems Board in the Department of Public Safety and Correctional Services.

(b) (1) The Board consists of 17 members.

(2) Of the 17 members:

(i) one member shall represent a telephone company operating in the State;

(ii) one member shall represent the wireless telephone industry in the State;

(iii) one member shall represent the Maryland Institute for Emergency Medical Services Systems;

(iv) one member shall represent the Department of State Police;

(v) one member shall represent the Public Service Commission;

(vi) one member shall represent the Association of Public-Safety Communications Officials International, Inc.;

(vii) two members shall represent county fire services in the State, with one member representing career fire services and one member representing volunteer fire services;

(viii) one member shall represent police services in the State;

(ix) two members shall represent emergency management services in the State;

(x) one member shall represent a county with a population of 200,000 or more;

(xi) one member shall represent a county with a population of less than 200,000;

(xii) one member shall represent the Maryland chapter of the National Emergency Numbers Association;

(xiii) one member shall represent the geographical information systems in the State; and

(xiv) two members shall represent the public.

(3) The Governor shall appoint the members with the advice and consent of the Senate.

(c) (1) The term of a member is 4 years and begins on July 1.

(2) The terms of the members are staggered as required by the terms provided for members of the Board on October 1, 2003.

(3) At the end of a term, a member continues to serve until a successor is appointed and qualifies.

(4) If a vacancy occurs after a term has begun, the Governor shall appoint a successor to represent the organization or group in which the vacancy occurs.

(5) A member who is appointed after a term has begun serves only for the rest of the term and until a successor is appointed and qualifies.

(d) The Governor shall appoint a chairperson from among the Board members.

(e) The Board shall meet as necessary, but at least once each quarter.

(f) A member of the Board:

(1) may not receive compensation as a member of the Board; but

(2) is entitled to reimbursement for expenses under the Standard State Travel Regulations, as provided in the State budget.

(g) The Secretary shall provide staff to the Board, including:

(1) a coordinator who is responsible for the daily operation of the office of the Board; and

(2) staff to handle the increased duties related to wireless enhanced 9-1-1 service.

**§ 1-306.**

(a) The Board shall coordinate the enhancement of county 9-1-1 systems.

(b) The Board's responsibilities include:

(1) establishing planning guidelines for enhanced 9-1-1 system plans and deployment of wireless enhanced 9-1-1 service in accordance with this subtitle;

(2) establishing procedures to review and approve or disapprove county plans and to evaluate requests for variations from the planning guidelines established by the Board;

(3) establishing procedures for the request for reimbursement of the costs of enhancing a 9-1-1 system by a county or counties in which a 9-1-1 system is in operation, and procedures to review and approve or disapprove the request;

(4) transmitting the planning guidelines and procedures established under this section, and any amendments to them, to the governing body of each county;

(5) submitting to the Secretary each year a schedule for implementing the enhancement of county or multicounty 9-1-1 systems, and an estimate of funding requirements based on the approved county plans;

(6) developing, with input from counties, and publishing on or before July 1, 2004, an implementation schedule for deployment of wireless enhanced 9-1-1 service;

(7) reviewing and approving or disapproving requests for reimbursement of the costs of enhancing 9-1-1 systems, and submitting to the Secretary each year a schedule for reimbursement and an estimate of funding requirements;

(8) reviewing the enhancement of 9-1-1 systems;

(9) providing for an audit of county expenditures for the operation and maintenance of 9-1-1 systems;

(10) ensuring inspections of public safety answering points;

(11) reviewing and approving or disapproving requests from counties with operational enhanced 9-1-1 systems to be exempted from the expenditure limitations under § 1-312 of this subtitle; and

(12) authorizing expenditures from the 9-1-1 Trust Fund that:

- (i) are for enhancements of 9-1-1 systems that:
  1. are required by the Board;
  2. will be provided to a county by a third party contractor; and
  3. will incur costs that the Board has approved before the formation of a contract between the county and the contractor; and
- (ii) are approved by the Board for payment:
  1. from money collected under § 1-310 of this subtitle; and
  2. directly to a third party contractor on behalf of a county.
- (c) The guidelines established by the Board under subsection (b)(1) of this section:
  - (1) shall be based on available technology and equipment; and
  - (2) may be based on any other factor that the Board determines is appropriate, including population and area served by 9-1-1 systems.

**§ 1-307.**

- (a) The Board shall submit an annual report to the Governor, the Secretary, and, subject to § 2-1246 of the State Government Article, the Legislative Policy Committee.
- (b) The report shall provide the following information for each county:
  - (1) the type of 9-1-1 system currently operating in the county;
  - (2) the total 9-1-1 fee and additional charge charged;
  - (3) the funding formula in effect;
  - (4) any statutory or regulatory violation by the county and the response of the Board;
  - (5) any efforts to establish an enhanced 9-1-1 system in the county; and
  - (6) any suggested changes to this subtitle.

**§ 1-308.**

- (a) There is a 9-1-1 Trust Fund.
- (b) The purposes of the 9-1-1 Trust Fund are to:
  - (1) reimburse counties for the cost of enhancing a 9-1-1 system;
  - (2) pay contractors in accordance with § 1-306(b)(12) of this subtitle; and
  - (3) fund the coordinator position and staff to handle the increased duties related to wireless enhanced 9-1-1 service under § 1-305 of this subtitle, as an administrative cost.
- (c) The 9-1-1 Trust Fund consists of:
  - (1) money from the 9-1-1 fee collected and remitted to the Comptroller under § 1-310 of this subtitle;
  - (2) money from the additional charge collected and remitted to the Comptroller under § 1-311 of this subtitle; and
  - (3) investment earnings of the 9-1-1 Trust Fund.
- (d) Money in the 9-1-1 Trust Fund shall be held in the State Treasury.
- (e) The Secretary shall administer the 9-1-1 Trust Fund, subject to the guidelines for financial management and budgeting established by the Department of Budget and Management.
- (f) The Secretary shall direct the Comptroller to establish separate accounts in the 9-1-1 Trust Fund for the payment of administrative expenses and for each county.

- (g) (1) Any investment earnings shall be credited to the 9-1-1 Trust Fund.
- (2) The Comptroller shall allocate the investment income among the accounts in the 9-1-1 Trust Fund, prorated on the basis of the total fees collected in each county.

**§ 1-309.**

(a) On recommendation of the Board, each year the Secretary shall request an appropriation from the 9-1-1 Trust Fund in an amount sufficient to:

- (1) carry out the purposes of this subtitle;
- (2) pay the administrative costs chargeable to the 9-1-1 Trust Fund; and
- (3) reimburse counties for the cost of enhancing a 9-1-1 system.

(b) (1) Subject to the limitations under subsection (e) of this section, the Comptroller shall disburse the money in the 9-1-1 Trust Fund as provided in this subsection.

(2) Each July 1, the Comptroller shall allocate sufficient money from the 9-1-1 fee to pay the costs of administering the 9-1-1 Trust Fund.

(3) As directed by the Secretary and in accordance with the State budget, the Comptroller, from the appropriate account, shall:

- (i) reimburse counties for the cost of enhancing a 9-1-1 system; and
- (ii) pay contractors in accordance with § 1-306(b)(12) of this subtitle.

(4) (i) The Comptroller shall pay to each county from its account the money requested by the county to pay the maintenance and operation costs of the county's 9-1-1 system in accordance with the State budget.

(ii) The Comptroller shall pay the money for maintenance and operation costs on September 30, December 31, March 31, and June 30 of each year.

(c) (1) Money accruing to the 9-1-1 Trust Fund may be used as provided in this subsection.

(2) Money collected from the 9-1-1 fee may be used to:

- (i) reimburse counties for the cost of enhancing a 9-1-1 system; and
- (ii) pay contractors in accordance with § 1-306(b)(12) of this subtitle.

(3) Money collected from the additional charge may be used by the counties for the maintenance and operation costs of the 9-1-1 system.

(d) (1) Reimbursement may be made only to the extent that county money was used to enhance the 9-1-1 system.

(2) Reimbursement for the enhancement of 9-1-1 systems shall include the installation of equipment for automatic number identification, automatic location identification, and other technological advancements that the Board requires.

(3) Reimbursement from money collected from the 9-1-1 fee may be used only for 9-1-1 system enhancements approved by the Board.

(e) (1) The Board may direct the Comptroller to withhold from a county money for 9-1-1 system expenditures if the county violates this subtitle or a regulation of the Board.

(2) (i) The Board shall state publicly in writing its reason for withholding money from a county and shall record its reason in the minutes of the Board.

(ii) On reaching its decision to withhold money, the Board shall notify the county.

(iii) The county has 30 days after the date of notification to respond in writing to the Board.

(3) (i) On notification by the Board, the Comptroller shall hold money for the county in the county's account in the 9-1-1 Trust Fund.

(ii) Money held by the Comptroller under subparagraph (i) of this paragraph does not accrue interest for the county.

(iii) Interest income earned on money held by the Comptroller under subparagraph (i) of this paragraph accrues to the 9-1-1 Trust Fund.

(4) County money withheld by the Comptroller shall be withheld until the Board directs the Comptroller to release the money.

(f) (1) The Legislative Auditor shall conduct fiscal/compliance audits of the 9-1-1 Trust Fund and of the appropriations and disbursements made for purposes of this subtitle.

(2) The cost of the fiscal portion of the audits shall be paid from the 9-1-1 Trust Fund as an administrative cost.

### **§ 1-310.**

(a) Each subscriber to switched local exchange access service or CMRS or other 9-1-1-accessible service shall pay a 9-1-1 fee.

(b) The 9-1-1 fee is 25 cents per month, payable when the bill for the telephone service or CMRS or other 9-1-1-accessible service is due.

(c) (1) The Public Service Commission shall direct each telephone company to add the 9-1-1 fee to all current bills rendered for switched local exchange access service in the State.

(2) Each telephone company:

(i) shall act as a collection agent for the 9-1-1 Trust Fund with respect to the 9-1-1 fees;

(ii) shall remit all money collected to the Comptroller on a monthly basis; and

(iii) is entitled to credit, against the money from the 9-1-1 fees to be remitted to the Comptroller, an amount equal to 0.75% of the 9-1-1 fees to cover the expenses of billing, collecting, and remitting the 9-1-1 fees and any additional charges.

(3) The Comptroller shall deposit the money remitted in the 9-1-1 Trust Fund.

(d) (1) Each 9-1-1 service carrier shall add the 9-1-1 fee to all current bills rendered for CMRS or other 9-1-1-accessible service in the State.

(2) Each 9-1-1 service carrier:

(i) shall act as a collection agent for the 9-1-1 Trust Fund with respect to the 9-1-1 fees;

(ii) shall remit all money collected to the Comptroller on a monthly basis; and

(iii) is entitled to credit, against the money from the 9-1-1 fees to be remitted to the Comptroller, an amount equal to 0.75% of the 9-1-1 fees to cover the expenses of billing, collecting, and remitting the 9-1-1 fees and any additional charges.

(3) The Comptroller shall deposit the money remitted in the 9-1-1 Trust Fund.

(4) The Board shall adopt procedures for auditing surcharge collection and remittance by CMRS providers.



(5) On request of a CMRS provider, and except as otherwise required by law, the information that the CMRS provider reports to the Board shall be confidential, privileged, and proprietary and may not be disclosed to any person other than the CMRS provider.

(e) Notwithstanding any other provision of this subtitle, the 9-1-1 fee does not apply to an intermediate service line used exclusively to connect a CMRS or other 9-1-1-accessible service, other than a switched local access service, to another telephone system or switching device.

(f) A CMRS provider that pays or collects 9-1-1 fees under this section has the same immunity from liability for transmission failures as that approved by the Public Service Commission for local exchange telephone companies that are subject to regulation by the Commission under the Public Utility Companies Article.

### **§ 1-311.**

(a) In addition to the 9-1-1 fee, the governing body of each county, by ordinance or resolution enacted or adopted after a public hearing, may impose an additional charge to be added to all current bills rendered for switched local exchange access service or CMRS or other 9-1-1-accessible service in the county.

(b) (1) The additional charge imposed by a county may not exceed 75 cents per month per bill.

(2) The amount of the additional charges may not exceed a level necessary to cover the total eligible maintenance and operation costs of the county.

(c) The additional charge continues in effect until repealed or modified by a subsequent county ordinance or resolution.

(d) After imposing, repealing, or modifying an additional charge, the county shall certify the amount of the additional charge to the Public Service Commission.

(e) The Public Service Commission shall direct each telephone company that provides service in a county that imposed an additional charge to add, within 60 days, the full amount of the additional charge to all current bills rendered for switched local exchange access service in the county.

(f) Within 60 days after a county enacts or adopts an ordinance or resolution that imposes, repeals, or modifies an additional charge, each 9-1-1 service carrier that provides service in the county shall add the full amount of the additional charge to all current bills rendered for CMRS or other 9-1-1-accessible service in the county.

(g) (1) Each telephone company and each 9-1-1 service carrier shall:  
(i) act as a collection agent for the 9-1-1 Trust Fund with respect to the additional charge imposed by each county;

(ii) collect the money from the additional charge on a county basis; and

(iii) remit all money collected to the Comptroller on a monthly basis.

(2) The Comptroller shall deposit the money remitted in the 9-1-1 Trust Fund account maintained for the county that imposed the additional charge.

### **§ 1-312.**

(a) During each county's fiscal year, the county may spend the amounts distributed to it from 9-1-1 fee collections for the installation, enhancement, maintenance, and operation of a county or multicounty 9-1-1 system.

(b) Subject to the provisions of subsection (c) of this section, maintenance and operation costs may include telephone company charges, equipment costs, equipment lease charges, repairs, utilities, personnel costs, and appropriate carryover costs from previous years.

(c) During a year in which a county raises its local additional charge under § 1-311 of this subtitle, the county:

(1) may use 9-1-1 trust funds only to supplement levels of spending by the county for 9-1-1 maintenance or operations; and

(2) may not use 9-1-1 trust funds to supplant spending by the county for 9-1-1 maintenance or operations.

(d) The Board shall provide for an audit of each county's expenditures for the maintenance and operation of the county's 9-1-1 system.

(e) (1) For a county without an operational Phase II wireless enhanced 9-1-1 system within the time frames established by the Board under § 1-306(b)(6) of this subtitle, the Board shall adopt procedures, to take effect on or after January 1, 2006, to assure that:

(i) the money collected from the additional charge and distributed to the county are expended during the county's fiscal year as follows:

1. for a 9-1-1 system in a county or a multicounty area with a population of 100,000 individuals or less, a maximum of 85% may be spent for personnel costs; and

2. for a 9-1-1 system in a county or multicounty area with a population of over 100,000 individuals, a maximum of 70% may be spent for personnel costs; and

(ii) the total amount collected from the 9-1-1 fee and the additional charge shall be expended only for the installation, enhancement, maintenance, and operation of a county or multicounty system.

(2) The Board may grant an exception to the provisions of paragraph (1) of this subsection in extenuating circumstances.

(3) A county with an operational Phase II wireless enhanced 9-1-1 system is exempt from the provisions of paragraph (1) of this subsection.

# **CODE OF MARYLAND REGULATIONS**

*12.11.03.00*

Title 12 DEPARTMENT OF PUBLIC SAFETY AND CORRECTIONAL SERVICES

## ***Subtitle 11 OFFICE OF THE SECRETARY***

### **Chapter 03 9-1-1 Emergency Telephone System**

**Authority: Public Safety Article, Title 1, Subtitle 3, Correctional Services Article, §2-109; Annotated Code of Maryland**

*12.11.03.01*

#### **.01 Emergency Number Systems Board Authority.**

The Emergency Number Systems Board shall coordinate the implementation, enhancement, maintenance, and operation of county or multicounty 9-1-1 systems.

*12.11.03.02*

#### **.02 Definitions.**

A. In this chapter, the following terms have the meanings indicated.

B. Terms Defined.

(1) "Additional charge" has the meaning stated in Public Safety Article, §1-301, Annotated Code of Maryland.

(2) "Board" means the Emergency Number Systems Board.

(3) "9-1-1 system" means a telephone service or any other communication service that meets the planning guidelines under Public Safety Article, §1-306, Annotated Code of Maryland, and automatically connects an individual dialing the digits 9-1-1 to a public safety answering point.

(4) "Public safety answering point" has the meaning stated in Public Safety Article, §1-301, Annotated Code of Maryland.

*12.11.03.03*

#### **.03 The Emergency Number Systems Board.**

A. The Emergency Number Systems Board is under the direction of the Secretary of Public Safety and Correctional Services.

B. Board membership shall be according to Public Safety Article, §1-305, Annotated Code of Maryland.

C. The Board shall meet as necessary, but not less than quarterly each calendar year.

- D. The Board requires a majority of confirmed members present at a meeting to constitute a quorum.
- E. The Board requires a majority vote of members present at a meeting before taking action.
- F. The Board shall coordinate enhancement of county or multicounty 9-1-1 systems according to provisions under Public Safety Article, §1-306, Annotated Code of Maryland.

*12.11.03.04*

#### **.04 Implementation by County or Multicounty Area.**

A county or multicounty area shall maintain an enhanced 9-1-1 system that:

- A. Uses the digits 9-1-1 as the published emergency telephone number for access to emergency services;
- B. Has public safety answering points that provide 24-hour public access and dispatch service;
- C. Provides transfer and referrals to related public safety services;
- D. Provides for staffing all public safety answering points with personnel trained as required by this chapter;
- E. Provides for equipping all public safety answering points with adequate access to TTY equipment to facilitate use by an individual with a speech or hearing disability;
- F. Provides access to services for an individual who does not speak or understand the English language;
- G. May provide access to local emergency management centers for all public safety answering points;
- H. Permits a county to designate a public safety answering point using cooperative arrangements acceptable to the participating agencies;
- I. Permits public safety answering points to transfer or relay emergency calls received requiring services outside of the jurisdiction of the system receiving the call;
- J. Maintains a current master street address guide and communicates updated information to parties responsible for an automatic number identification (ANI) and automatic location identification (ALI) system;
- K. Uses telephone equipment and services that provide:
  - (1) A visual or audible indication, or both, of an incoming call;
  - (2) The capability for the call taker to monitor a transferred call to ensure that the call is properly transferred;
  - (3) Annual telephone company monitoring of service to determine the grade of service and, if appropriate, to make recommendations to ensure that not more than one busy signal in every 100 incoming calls during an average busy hour is maintained; and
  - (4) Documentation of the date and time a 9-1-1 call is received; and
- L. Has a sufficient number of call takers and equipment to consistently answer incoming calls on a daily average of 10 seconds or less.

12.11.03.05

### **.05 Plans for More Than One Public Safety Answering Point in a County.**

A county with a plan for more than one public safety answering point in the county shall submit the plan to the Board for consideration subject to the following:

- A. The county administration submitting the plan and not the individual agency within the county shall receive and distribute funding; and
- B. The plan shall meet the criteria established under this chapter, unless the Board approves a variation.

12.11.03.06

### **.06 Minimum Enhanced 9-1-1 System Requirements.**

At a minimum, an enhanced 9-1-1 system implemented in Maryland shall include:

- A. Sufficient incoming 9-1-1 lines for each telephone central office to ensure that not more than one in 100 call attempts during the average busy hour is blocked;
- B. Connections to all public safety agencies covered by the system;
- C. 24 hour, 7 day operation of the public safety answering point staffed with personnel trained as required under this chapter;
- D. First priority to answering 9-1-1 calls;
- E. Electronic recording of all 9-1-1 calls;
- F. Playback capability of all 9-1-1 calls;
- G. Connection to adjacent public safety answering points by private lines when there is a telephone exchange and jurisdictional boundary not covered by selective routing;
- H. Security measures sufficient to minimize intentional disruption of the operation;
- I. Standby emergency electrical power to keep the public safety answering point operating when commercial power fails;
- J. At least one administrative line for nonemergency calls;
- K. Written operational procedures;
- L. Automatic location identification (ALI) which displays, at the public safety answering point, the address or location of the calling instrument;
- M. Automatic number identification (ANI) which displays, at the public safety answering point, the calling telephone number;

N. Central office identification used to identify dedicated lines or trunks from a central office when a public safety answering point serves more than one central office;

O. A distinct tone, visible signal, or other process for:

- (1) Alerting the call taker that an incoming 9-1-1 call was disconnected; and
- (2) Receiving and displaying the telephone number with ANI and ALI information for a disconnected 9-1-1 call, when available;

P. Providing access to services for an individual:

- (1) With a speech or hearing disability; or
- (2) Who does not speak or understand the English language; and

Q. Other technical advances approved by the Board.

*12.11.03.07*

### **.07 Minimum Features of a 3-1-1 System.**

A. A county or multicounty system may establish a 3-1-1 system to reduce congestion on the 9-1-1 system operation.

B. At a minimum, a 3-1-1 system shall include the following:

- (1) Switching or programming to direct a 3-1-1 call to a nonemergency answering position;
- (2) A 3-1-1 answering position that shall be capable of:
  - (a) Immediately transferring an emergency call to a 9-1-1 answering position or an adjoining public safety answering point;
  - (b) Transferring a nonemergency call to an adjoining jurisdiction or appropriate agency; and
  - (c) Providing an individual:
    - (i) With a speech or hearing disability access to TTY services; or
    - (ii) Who does not speak or understand the English language access to alternative communication services; and
- (3) A 3-1-1 call taker trained to handle nonemergency calls and to transfer emergency calls to a 9-1-1 call taker.

*12.11.03.08*

### **.08 Operational Plan.**

A. A county or multicounty system shall have and maintain a written operational plan for public safety services signed by public safety agencies within the public safety answering point area of responsibility.

B. A public safety agency included in an operational plan under §A of this regulation shall be familiar with the operational procedures of the other public safety agencies included in the same operational plan.

C. An operational plan shall provide for uniform methods and procedures to ensure effective interagency communications.

*12.11.03.09*

### **.09 Safeguarding Telephone Circuits by Telephone Companies.**

A. A facility housing 9-1-1 telephone equipment shall:

- (1) Be equipped at all exposed terminations, including central office distributing frames, with protective devices that prevent accidental worker contact; and
- (2) Include clearly identified protected terminations to distinguish protected terminations from other circuitry.

B. A protected circuit may not be opened, grounded, short-circuited, or manipulated in any way by a telephone company worker without the local telephone company first obtaining approval for circuit release from the appropriate public safety answering point.

C. A telephone company shall ensure that telephone company employees who work in facilities associated with the 9-1-1 service are familiar with procedures for safeguarding 9-1-1 system equipment.

*12.11.03.10*

### **.10 Public Safety Answering Point Training.**

A. A county shall staff a public safety answering point with personnel who can properly process a call from a machine used by an individual who has a speech or hearing impairment.

B. Within 6 months of hiring a public safety answering point call taker, a county shall train the new call taker using a curriculum adopted or approved by the Board.

C. A county shall provide a public safety answering point call taker with yearly in-service training using a curriculum adopted or approved by the Board.

D. Training shall include:

- (1) Public safety answering point orientation;
- (2) Communication skills;
- (3) Electronic systems;
- (4) Policies and procedures;
- (5) Call processing;
- (6) Documentation;
- (7) Dispatch procedures;
- (8) Stress management;
- (9) Public relations;
- (10) Administrative duties; and
- (11) Disaster and major incident training.

12.11.03.11

### **.11 9-1-1 Fees.**

A. The Board shall ensure that collection, maintenance, dispersal, and auditing of 9-1-1 fees is conducted according to Public Safety Article, §§1-308—1-312, Annotated Code of Maryland.

B. Additional Charges—Local Government.

(1) In addition to the fee charged under Public Safety Article, §1-310, Annotated Code of Maryland, a county with an operational 9-1-1 system under Public Safety Article, §1-304, Annotated Code of Maryland, may, by ordinance or resolution after public hearing, enact or adopt an additional monthly charge not to exceed the limits under Public Safety Article, §1-311, Annotated Code of Maryland, to be applied to current bills, within that county, for:

(a) Switched local exchange access service; and

(b) Wireless telephone service or other 9-1-1 accessible service.

(2) A county authorizing an additional charge under §B of this regulation and maintaining an enhanced 9-1-1 system shall be subject to an annual Board-authorized independent audit of authorized 9-1-1 expenditures pursuant to Public Safety Article, §1-312, Annotated Code of Maryland.

12.11.03.12

### **.12 Equipment Which Qualifies for Funding or Reimbursement.**

A. Equipment that qualifies for purchase with funds from the 9-1-1 Trust Fund includes:

- (1) Equipment for connecting and outswitching 9-1-1 calls within a telephone central office;
- (2) Trunking facilities from the central office to a public safety answering point;
- (3) Equipment to connect 9-1-1 calls to the appropriate public safety agency; and
- (4) Equipment for a 3-1-1 system.

B. Equipment necessary to constitute an enhanced 9-1-1 system shall be used for:

- (1) Automatic number identification (ANI);
- (2) Automatic location identification (ALI); or
- (3) Other technical equipment the Board may require.

C. Computer aided dispatch equipment is not a part of a 9-1-1 system, except when the Board determines that an interface is necessary to properly process 9-1-1 calls.

12.11.03.13

### **.13 Submission of 9-1-1 Plan.**

A. A county requesting reimbursement from the 9-1-1 Trust Fund for mandated equipment, 9-1-1 enhancements, or technological advancements shall submit the request to the Board for approval.



B. A county shall submit a plan, request, report, or question to the Chairman, Emergency Number Systems Board.

*12.11.03.14*

### **.14 Request for Reimbursement from the 9-1-1 Trust Fund.**

A. A county shall submit a request for reimbursement from the 9-1-1 Trust Fund to the Board in a format and according to procedures established by the Board.

B. Reimbursement Processing.

(1) A county public safety answering point director or a 9-1-1 administrator shall submit a written or electronic request for reimbursement to the Board so that it is received at least 2 weeks before a Board meeting at which it is to be considered.

(2) The county's public safety answering point director or 9-1-1 administrator, or a designee, shall attend the meeting at which the request is to be considered.

(3) The Board shall review the request and, if approved, encumber funds up to the amount of the request.

(4) The county shall ensure that the county's procurement laws and policies are followed.

*12.11.03.15*

### **.15 Variations or Waivers of Regulations.**

A. Upon request by a county, the Board may grant a waiver or variance of the regulations contained in this chapter.

B. A county may submit a written or electronic request for waiver or variance to the Board that includes:

- (1) Number of persons affected;
- (2) Impact of a variance or waiver;
- (3) Alternative methods;
- (4) Technical difficulties;
- (5) Cost.

C. The Board shall consider:

- (1) The information for each of the areas cited in §B of this regulation; and
- (2) The best interests of the affected parties, the applicant, and the Emergency Number Systems Board.

D. An affected party shall have the right to present, either in writing or through oral testimony, information which may bear on the Board's final decision.

E. Processing a Request for Waiver or Variance.

(1) Upon receipt of a written request for waiver or variance, the Board shall:

(a) Within 10 days of receipt of the request, direct a letter to the applicant, which shall:

(i) Acknowledge receipt; and

(ii) Notify the applicant that additional information may be submitted, within 30 days, for the Board to consider during the review; and

(b) Review the documents or conduct a hearing.

(2) If the Board elects to review the documents, the review shall be conducted at a regular Board meeting within 60 days after the expiration of the 30-day period granted to the applicant to submit additional information.

(3) If the Board elects to conduct a hearing, the Board shall:

(a) Notify the applicant and affected parties of the hearing at least 10 days before the hearing and provide the hearing:

(i) Date;

(ii) Time; and

(iii) Location; and

(b) Conduct the hearing according to State Government Article, Title 10, Subtitle 2, Annotated Code of Maryland.

*12.11.03.16*

## **.16 9-1-1 System Violations.**

A. The Board may instruct the State Comptroller to withhold funds from a county for 9-1-1 system expenditures for a violation under:

- (1) Public Safety Article, §1-312, Annotated Code of Maryland; or
- (2) The regulations in this chapter.

B. Withholding Funds.

(1) If the Board decides to withhold funds, the Board shall:

(a) Identify, in writing, the reason or reasons for withholding funds;

(b) Record the reason or reasons in the minutes of the meeting;

(c) Notify the county that the county has 30 days from the date of notification to respond in writing to the Board; and

(d) Notify the State Comptroller to hold funds, in that county's account within the 9-1-1 Trust Fund, until the Board advises the Comptroller that the funds may be released.

(2) Funds held by the Comptroller under this section may not accrue interest for a county.

(3) Interest income earned on funds held by the Comptroller under this regulation shall be diverted to the 9-1-1 Trust Fund.

C. The Board shall notify the Secretary of action taken under §A or B of this regulation.

12.11.03.17

### **.17 Decisions of the Board.**

After the Board conducts a hearing or a review of a request under this chapter, the Board shall ensure that the Board's decision is:

- A. In writing and stated in the record;
- B. Accompanied by findings of fact and conclusions; and
- C. Provided to the applicant with a copy of the written record containing the information noted under §§A and B of this regulation.