

PROJECT NO.	DATE	DESIGN NO.	SHEET NO.	TOTAL SHEETS
2	MD	95-4122135	10	115

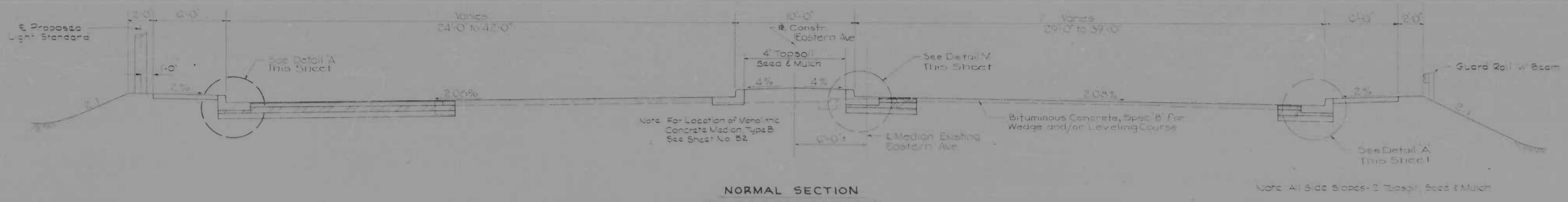

**NORMAL SECTION
EASTERN AVENUE**

Scale 1/4" = 1'-0"
Sta 4+18 to Sta 17+00 E.B.
Sta 4+18 to Sta 17+50 W.B.

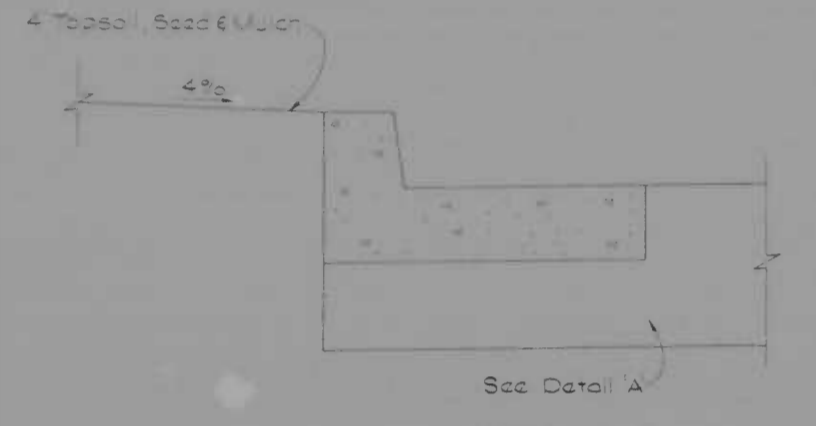

DETAIL M
Scale 1" = 1'-0"

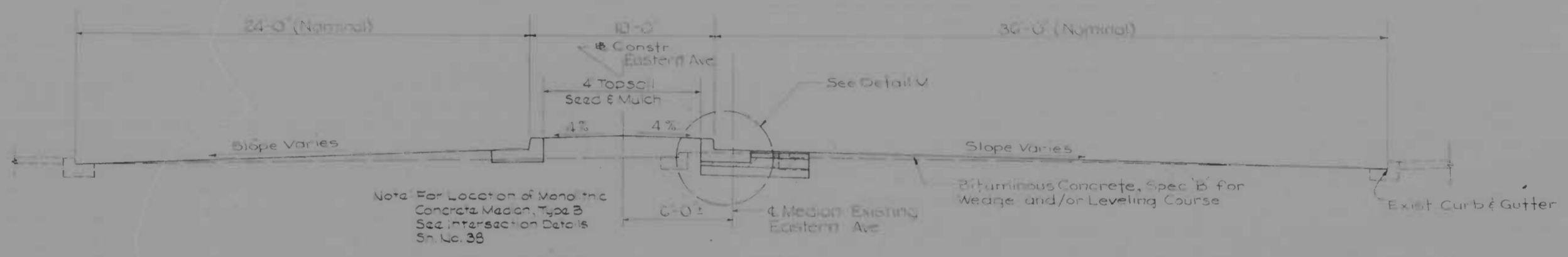

**NORMAL SECTION
EASTERN AVENUE**

Scale 1/4" = 1'-0"
Sta 0+60 to Sta 4+10

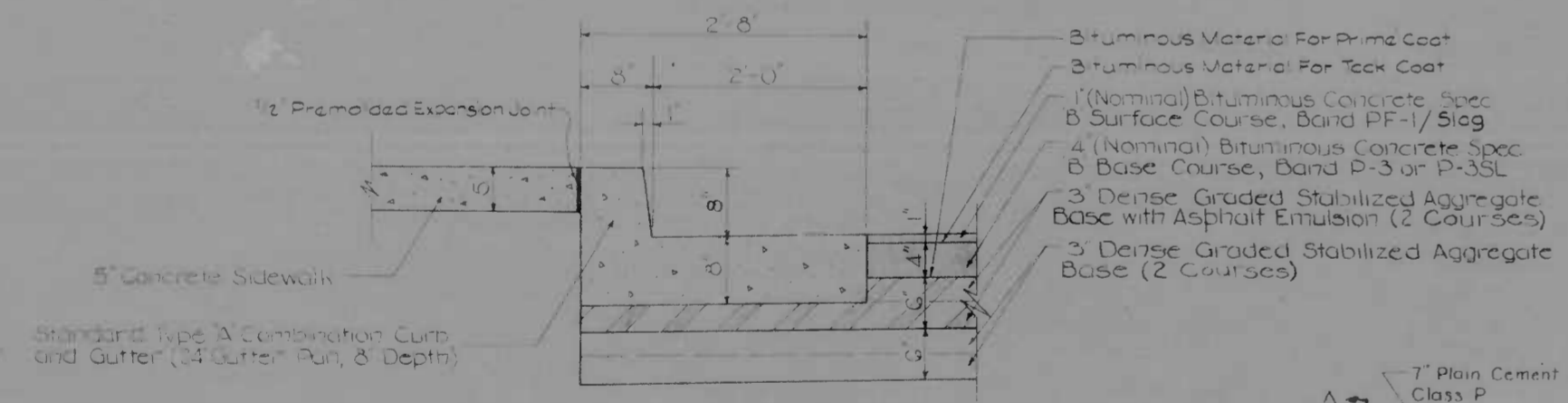

DETAIL A
Scale 1" = 1'-0"

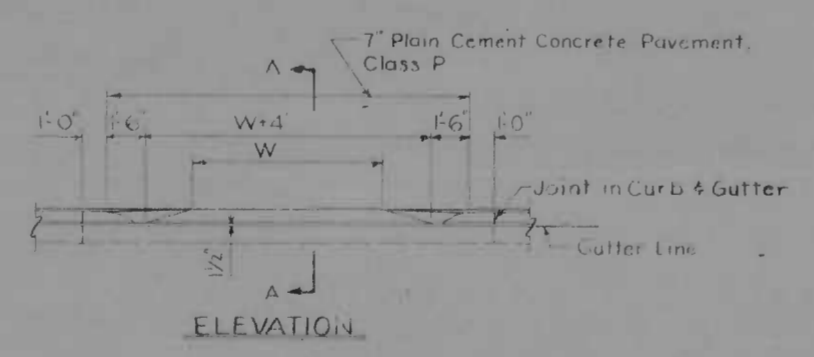

CONCRETE DRIVEWAY APRON DETAILS

Scale 1" = 5'-0"

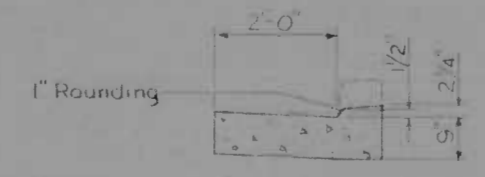

DEPRESSED CURB DETAIL

Scale 3/4" = 1'-0"

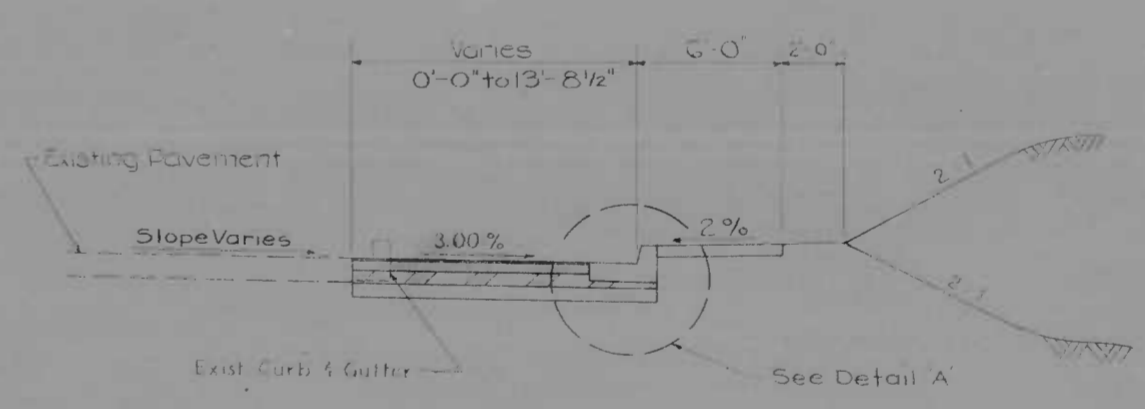

**NORMAL SECTION
KANE STREET**

Scale 1" = 5'-0"

REVISIONS	CONSULTANT	CITY OF BALTIMORE DEPARTMENT OF PUBLIC WORKS	STATE ROADS COMMISSION OF MARYLAND INTERSTATE DIVISION FOR BALTIMORE CITY
	KMCERLE, BECKER, STONE & ASSOC., INC. AND MATZ, CHILDS & ASSOC., INC. CONSULTING ENGINEERS 341 N. CALVERT STREET BALTIMORE, MARYLAND 21202	INTERSTATE ROUTE 95 EASTERN AVENUE INTERCHANGE	DRAWN BY: R.W.F. TRACED BY: J.V.F. F.A.P. NO. 95-4122135 S.R.C. NO. BS 248-25-915 BALTO. CITY NO. 1958
		SCALE: AS SHOWN	DES. BY: D.E.S. CHK. BY: V.F.F. DATE: 4-20-70
			SHEET NO. 10 OF 113

SUMMARY OF QUANTITIES

SHEET NO. 102 OF 113
DATE 6-3-70

STATION	DRAINAGE																												REMARKS								
	EA	EA	EA	EA	EA	EA	EA	EA	EA	EA	EA	EA	EA	EA	EA	EA	EA	EA	EA	EA	EA	EA	EA	EA	EA	EA	EA	EA		EA							
SHEET NO. 53																																					
1+07																															Eastern Avenue Rt						
1+72																															Eastern Avenue Rt						
2+80																															Eastern Avenue Rt						
3+70																															Eastern Avenue Rt						
4+06																															Eastern Avenue Lt						
4+70																															Eastern Avenue Lt						
5+45																															Eastern Avenue Rt						
5+54																															Eastern Avenue Lt						
5+62																															Eastern Avenue Lt						
5+78																															Eastern Avenue Rt						
6+15																															Eastern Avenue Lt						
6+58																															Eastern Avenue Rt						
6+72																															Eastern Avenue Rt						
6+80																															Eastern Avenue Lt						
5+35																															Eastern Avenue Lt						
4+00																															Ramp F Rt						
																															Ramp C Rt						
SHEET NO. 54																																					
8+00																															Ramp B Rt						
10+12																															Ramp B Rt						
11+57																															Ramp B Rt						
12+30																															Ramp B Rt						
13+50																															Ramp B Rt						
15+00																															Ramp B Lt						
15+87																															Ramp B Lt						
16+50																															Ramp B Lt & Rt						
7+30																															Ramp B Lt						
7+40																															Ramp C Lt						
348+85																															Ramp C Lt & Rt						
348+85																															I-95 Rt						
351+30																															I-95 Lt						
351+30																															I-95 Rt						
352+90																															I-95 Lt						
353+80																															I-95 Lt						
353+80																															I-95 Rt						
348+05																															I-95 Lt						
349+12																															I-95 Rt						
351+95																															I-95 Rt						
352+25																															I-95 Rt						
3+25																															I-95 Rt						
4+39																															Ramp E Rt						
4+85																															Ramp E Rt						
7+10																															Ramp E Rt						
7+15																															Ramp E Rt						
7+25																															Ramp E Rt						
7+75																															Ramp F Rt						
8+40																															Ramp F Rt						
9+15																															Ramp F Rt						
8+50 to 10+25																															Ramp E Rt						
TOTAL THIS SHEET																																					
TOTAL NO.	331	334	335	336	337	338	339	340	341	342	344	346	347	348	349	350	351	352	353	354	355	356	357	358	359	360	361	369	370	371	372	373	374	375	376	383	385

REVISIONS	CONSULTANT	CITY OF BALTIMORE DEPARTMENT OF PUBLIC WORKS	STATE ROADS COMMISSION OF MARYLAND INTERSTATE DIVISION FOR BALTIMORE CITY
	KINDIG, BENDER, STONE & ASSOC., INC. 440 MATZ, CHLOS & ASSOC., INC. CONSULTING ENGINEERS 141 N. CALVERT STREET BALTIMORE, MARYL. 21202	INTERSTATE ROUTE, 95 EASTERN AVENUE INTERCHANGE	DRAWN BY: JJK TRACED BY: JJK DES. BY: JGC CHK. BY: HEL
		SCALE:	F.A.P. NO. 1-95-432136 S.P.C. NO. BC 245-39-B15 BALTO. CITY NO. 1259
		DATE: 6-3-70	SHEET NO. 102 OF 113

EARTHWORK SUMMARY

2 MD. 1-95-4(32)36 109 113

STATION		EMBANKMENT	TOP SOIL		UNSUITABLE MATERIAL		CLASS	CUT		REMARKS
FROM	TO		CUT	FILL	CUT	FILL		ADJUSTED	DENSIFIED	
MAINLINE 1-35										
328+00	336+00						145			Side Ditch Rt.
332+00	340+00	122,460								
336+00	335+00			1,480						6" Top Soil Under Fill, Refill
334+00	335+00				25					6" Root Mat Under Fill, Refill
334+00	337+00				560					6" Root Mat In Cut
334+00	338+00	8,008					4,448	4,181		S.F. = 0.94
336+00	356+00	219,000					209,297	203,018		S.F. = 0.97
338+00	339+00				406					6" Root Mat Under Fill, Refill
338+00	342+00				1,540					6" Root Mat In Cut
342+00	344+00				1,150					6" Root Mat In Cut
345+00	347+00			83						3" Topsoil In Cut
348+00	352+00				1,850					6" Root Mat In Cut
348+00	359+00			1,250						6" Topsoil In Cut
352+00	359+00				830					6" Root Mat In Cut
354+00	370+00	183,086								
355+00	370+00				596					6" Root Mat Under Fill, Refill
358+00	370+00						212			Side Ditch Rt.
358+00	362+00	487					167	152		S.F. = 0.94
359+00	362+00				325					6" Root Mat In Cut
SUB TOTAL		721,495	339,546	1,333	1,480	6,255	1,047	857	213,907	207,351
RAMP 'A'										
0+00	12+61	78,914						76,751	74,448	S.F. = 0.97
0+00	1+00			113						3" Topsoil In Cut
1+00	12+00				2,050					6" Root Mat In Cut
1+50	3+00	51								
SUB TOTAL		78,914	51	113	2,050			76,751	74,448	
RAMP 'B'										
0+64	9+00	12,136								
2+00	8+00						112			Side Ditch Rt.
3+00	8+00				96					6" Root Mat Under Fill, Refill
7+50	19+00	26,326					24,384	23,652		S.F. = 0.97
8+00	12+00				928					6" Root Mat In Cut
9+00	16+00			90						6" Top Soil In Cut
13+00	17+00				808					6" Root Mat In Cut
17+00	18+00			116						3" Top Soil In Cut
15+50	19+75	158								
SUB TOTAL		26,326	12,304	206	1,736	96	112	24,384	23,652	
RAMP 'C'										
0+00	13+36	88,654						87,413	84,791	S.F. = 0.97
6+00	4+00		57							
4+00	7+00				883					6" Root Mat In Cut
7+00	9+00				275					6" Root Mat In Cut
7+00	10+00			83						3" Top Soil In Cut
SUB TOTAL		88,654	57	83	1,158			87,413	84,791	

STATION		EMBANKMENT	TOP SOIL		UNSUITABLE MATERIAL		CLASS	CUT		REMARKS
FROM	TO		CUT	FILL	CUT	FILL		ADJUSTED	DENSIFIED	
RAMP 'D'										
10+00	14+00	4,072								
10+00	13+00				167					6" Root Mat Under Fill, Refill
10+00	14+00						72			Side Ditch Rt.
13+00	22+13	8,152					6,772	6,569		S.F. = 0.97
17+00	18+00									Side Ditch Rt.
19+00	22+00						94			Side Ditch Rt.
18+36	20+50	162								
21+00	22+13	33		32						3" Top Soil In Cut
13+00	19+00				1,045					6" Root Mat In Cut
20+00	21+00				299					6" Root Mat In Cut
SUB TOTAL		8,152	4,267	32	1,348	167	244	6,772	6,569	
RAMP 'E'										
0+00	11+72	28,929						27,395	27,395	S.F. = 1.00
1+00	11+72	287								
2+00	8+00			1,040						6" Top Soil In Cut
1+50	11+72						132			Interchange Ditch Rt.
3+00	5+00				219					6" Root Mat In Cut
8+00	11+00				275					6" Root Mat In Cut
SUB TOTAL		28,929	287	1,040	494		132	27,395	27,395	
RAMP 'F'										
4+50	5+50	610						610	573	S.F. = 0.94
4+50	10+12	22,467								
5+00	8+00									6" Root Mat Under Fill, Refill
7+00	10+00				350					6" Topsoil Under Fill, Refill
5+00	10+00						72			Side Ditch Rt.
SUB TOTAL		610	22,467		350		72	610	573	
EASTERN AVENUE										
0+50	2+00	82						82	77	S.F. = 0.94
0+50	9+58	750								
4+00	6+00	79						79	74	S.F. = 0.94
12+64	17+50	1,585						1,585	1,490	S.F. = 0.94
12+64	21+00	1,205								
SUB TOTAL		1,746	1,955					1,746	1,541	
KANE STREET										
9+44	15+50	516	42					516	485	S.F. = 0.94
SUB TOTAL		516	270					516	485	
TOTAL		455,342	376,976	2,407	1,830	13,041	1,347	1,417	439,214	426,805
EASTERN AVENUE SE TOUR ROAD										
		6,173	507					95	5,988	S.F. = 0.97

* NOTE: Included in Mainline and Ramp Excavation

REVISIONS	CONSULTANT	CITY OF BALTIMORE DEPARTMENT OF PUBLIC WORKS	STATE ROADS COMMISSION OF MARYLAND INTERSTATE DIVISION FOR BALTIMORE CITY
	WENZEL HEADS, STUBB & ASSOC., INC. 1401 W. BELT ROAD BALTIMORE, MARYLAND 21202	INTERSTATE ROUTE 95 EASTERN AVENUE INTERCHANGE	DRAWN BY: JJK TRACED BY: JJK F.A.P. NO. 1-95-4(32)36 S.R.C. NO. 31 242 25 B1E BALTO. CITY NO. 1588
		SCALE: _____ DATE: 6-3-70	DES BY: JGC CHK BY: HEL SHEET NO. 113

REV. NO.	DATE	BY	CHK.	SHEET NO.	TOTAL SHEETS
2	MD. 1-95-4132136			11	113

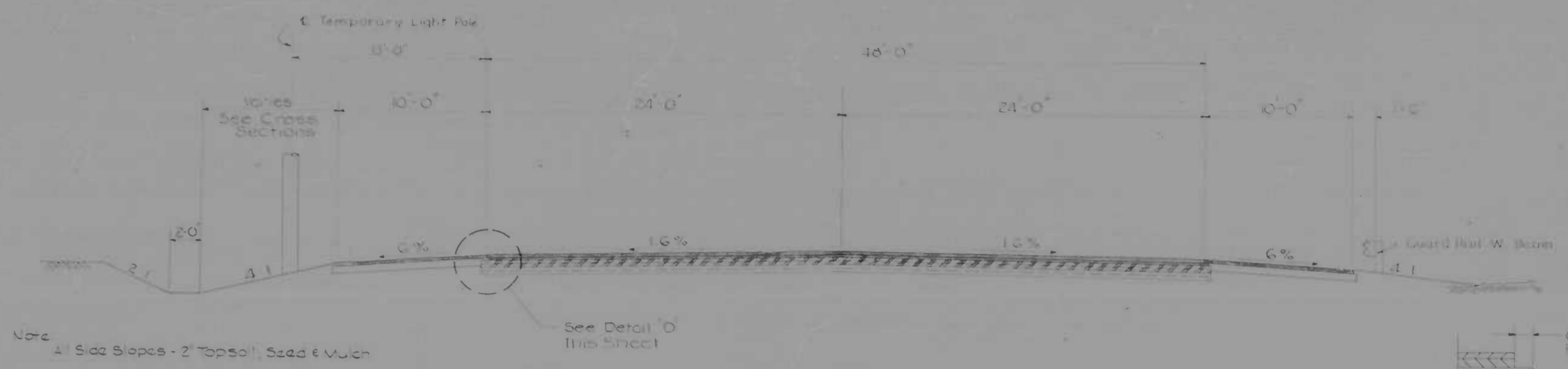

NORMAL SECTION

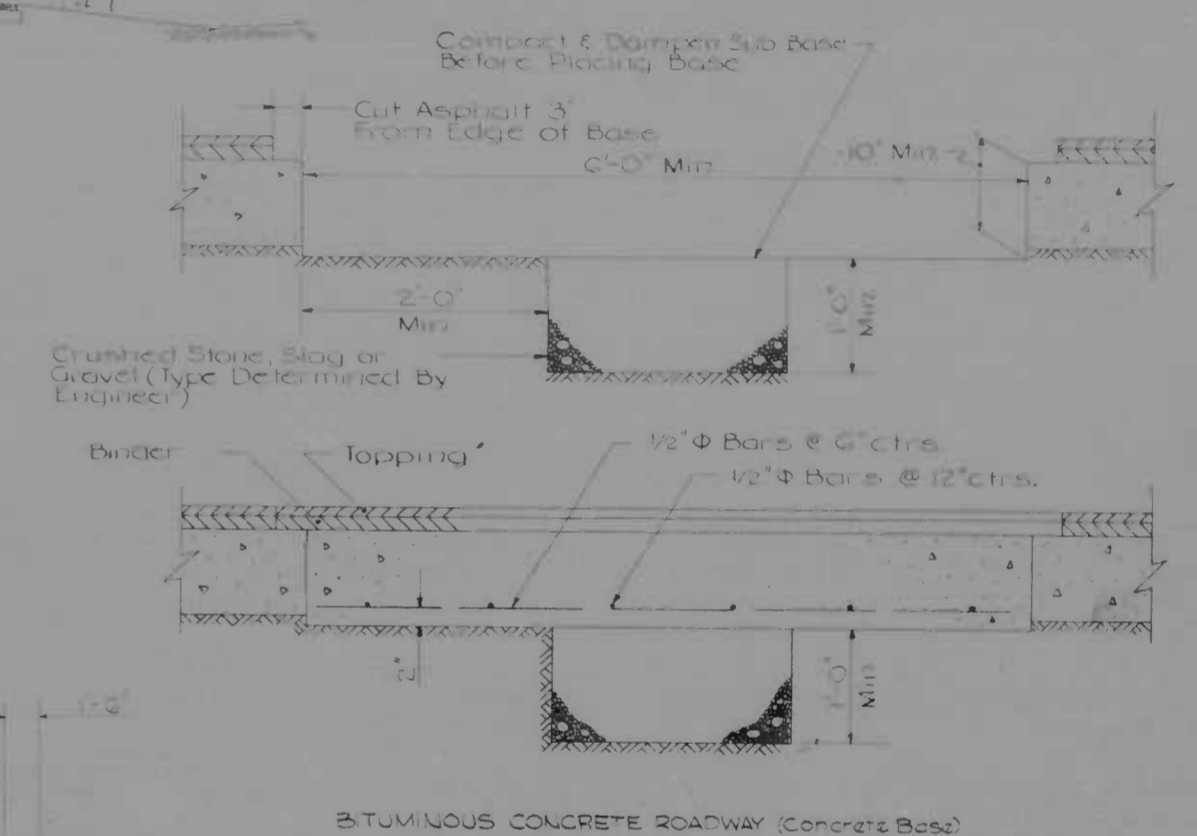

CUTTING & REPAIRING ROAD OPENINGS
Scale 1"=1'-0"

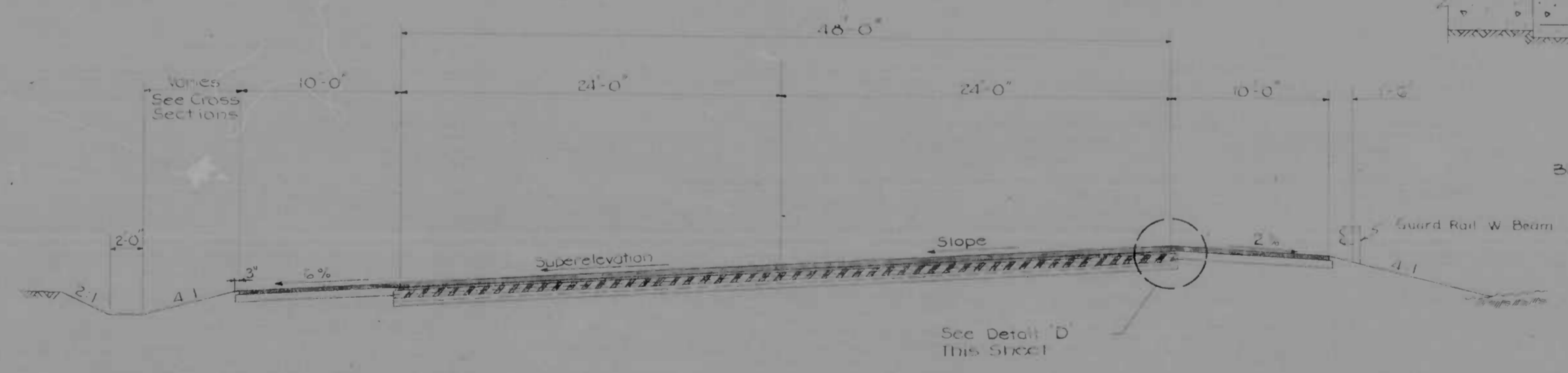

SUPERELEVATED SECTION

Note: For Superelevation Table See Sheet No 20

EASTERN AVENUE DETOUR ROAD

Scale 1"=5'-0"

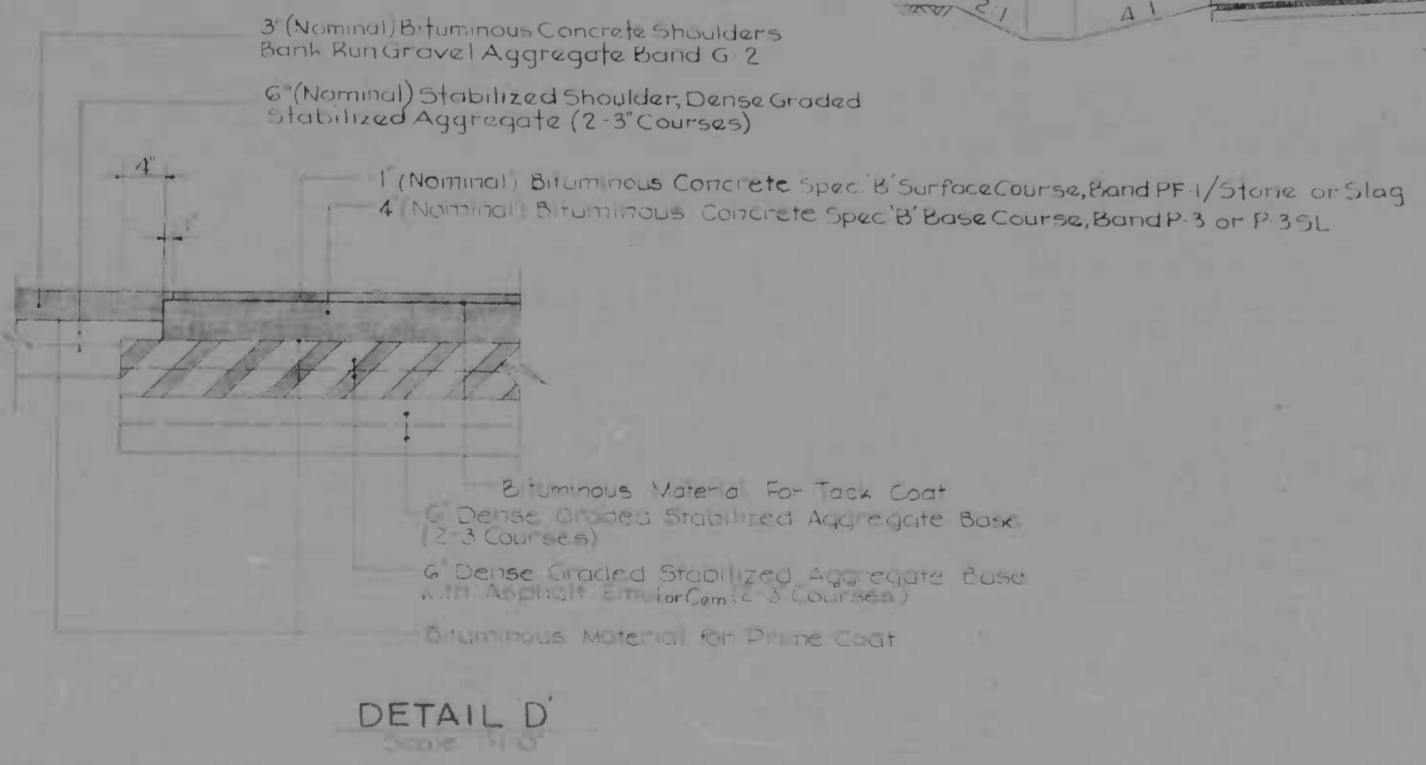

DETAIL D
Scale 1"=1'-0"

Notes: Backfill in Trench Shall Be Material Removed Therefrom or Better & Shall Be Thoroughly Compacted in Six (6) Inch Layers, by Tamping or by Some Other Approved Method to Within One (1) Foot of the Top of Sub-Grade. The Remaining Depth of the Trench shall Be Filled With Thoroughly Compacted, Crushed Stone, Slag or Gravel. Whenever Shoring or Shoring is Required to Prevent Cave-Ins or Bulging Due to the Depth of Trench or Type of Material Encountered, the Shoring Wherever Found Necessary, Shall Remain in Place until Cut off One (1) Foot Below the Bottom of the Replaced Surfacing. The Minimum Depth of the Replaced Concrete Base or Concrete Roadway Shall Be Ten (10) Inches. Whenever a Trench Crosses a Concrete Roadway that has Joint Installations, the Entire Slab Between Shall Be Removed and Replaced. All Work is to Be Performed in Accordance With the Latest S.R.C. Specifications.

REVISIONS	CONSULTANT	CITY OF BALTIMORE DEPARTMENT OF PUBLIC WORKS	STATE ROADS COMMISSION OF MARYLAND INTERSTATE DIVISION FOR BALTIMORE CITY
	KNORLE, BENDER, STONE & ASSOC., INC. 400 MATZ, CHUDS & ASSOC., INC. CONSULTING ENGINEERS 341 N. CALVERT STREET BALTIMORE, MARYLAND 21202	INTERSTATE ROUTE 95 EASTERN AVENUE INTERCHANGE	DRAWN BY J.J.K. DES. BY D.E.S. TRACED BY J.J.K. CHK. BY G.W.H. F.A.P. NO. 1-95-4132136 S.R.C. NO. 86-246-25-210 BALTO. CITY NO. 1959
		SCALE: 1"=5'-0"	DATE: 10-16-89
			SHEET NO. 11 OF 113

EARTHWORK SUMMARY

SHEET NO.	2	STATE	MD	PROJECT NO.	I-95-4(32)36	SHEET NO.	110	TOTAL SHEETS	113
-----------	---	-------	----	-------------	--------------	-----------	-----	--------------	-----

ROADSIDE IMPROVEMENT ITEMS	UNIT	ITEM NO.	ESTIMATED QUANTITY	PROPOSAL QUANTITY
Placing Salvaged Topsoil 2 In. Depth	S. Y.	701	83,466	83,476
Topsoil Furnished & Placed 2 In. Depth	S. Y.	702	15,942	15,950
Topsoil Furnished & Placed 4 In. Depth	S. Y.	703	2,391	2,400
Seeding & Mulching	S. Y.	704	99,408	99,420
Seeding & Mulching Flat Areas	S. Y.	705	2,391	2,400
Soils Seeding	S. Y.	706	5,766	5,770

2 IN TOPSOIL REQUIRED

1-95	57,389
Ramp A	9,369
Ramp B	5,808
Ramp C	9,902
Ramp D	2,711
Ramp E	6,122
Ramp F	3,724
Eastern Avenue Detour Rd	4,383
	99,408 S. Y.

4 IN TOPSOIL REQUIRED

Eastern Avenue	1,248
Ramp 'D' & 'D' Spur (Island)	178
Ramp 'D' & Ramp 'A' (Island)	604
Eastern Avenue & Kane Street (Island)	178
Ramp 'B' & 'B' Spur (Island)	183
	2,391 S. Y.

CLASS '1' EXCAVATION

Cut	455,348 Cu. Yds.
Plus Detour Road Embankment Less 95 C. Y. Class 2	406 Cu. Yds.
Plus Top Soil Removed Under Fill	1,850 Cu. Yds.
Plus Root Mat Removed Under Fill	1,347 Cu. Yds.
Total Class '1' Excavation	458,951 Cu. Yds.

EXCAVATION AVAILABLE FOR EMBANKMENT

Total Class '1' Excavation	458,951 Cu. Yds.
Minus	
Top Soil Removed In Cut	2,807 Cu. Yds.
Top Soil Removed Under Fill	1,850 Cu. Yds.
Root Mat Removed In Cut	13,041 Cu. Yds.
Root Mat Removed Under Fill	1,347 Cu. Yds.
Cut Adjusted	439,906 Cu. Yds.
Cut Densified (426,805 Cu. Yds. Interchange Plus 486 Cu. Yds. Eastern Avenue Detour Road)	427,291 Cu. Yds.
Plus Class '2' Excavation Available For Embankment	1,258 Cu. Yds.
Total Excavation Available For Embankment	428,549 Cu. Yds.

CLASS '1-A' EXCAVATION

Undercutting	4,000 Cu. Yds.
Total Class '1-A' Excavation	4,000 Cu. Yds.

CLASS '2' EXCAVATION

From Grading Table	1,417 Cu. Yds.
From Detour Road	95 Cu. Yds.
From Pipe Sheet	256 Cu. Yds.
From Bridge Sheet	0 Cu. Yds.
Total Class '2' Excavation	1,768 Cu. Yds.
Loss Due to Handling and Densification	530 Cu. Yds.
Total Class '2' Excavation Available For Embankment	1,238 Cu. Yds.

EMBANKMENT REQUIRED

Embankment	376,976 Cu. Yds.
Eastern Avenue Detour Road	501 Cu. Yds.
Refill For Top Soil Removed Under Fill	1,850 Cu. Yds.
Refill For Root Mat Removed Under Fill	1,347 Cu. Yds.
Embankment Required	380,674 Cu. Yds.
Excavation Available for Embankment	428,549 Cu. Yds.
Waste	47,875 Cu. Yds.

SELECT BORROW EXCAVATION OR EQUIVALENT

Refill For Class '1-A' Excavation	4,000 Cu. Yds.
Contingent Borrow Excavation	4,000 Cu. Yds.
Contingent Borrow Excavation Densification (10%)	400 Cu. Yds.
Total Select Borrow	4,400 Cu. Yds.

PROPOSAL QUANTITIES

ITEM	PROPOSAL QUANTITY
Class '1' Excavation	459,700 Cu. Yds.
Class '1-A' Excavation	4,000 Cu. Yds.
Class '2' Excavation	1,800 Cu. Yds.
Contingent Borrow Excavation	4,400 Cu. Yds.
Test Pit Excavation	50 Cu. Yds.

REVISIONS	CONSULTANT	CITY OF BALTIMORE DEPARTMENT OF PUBLIC WORKS	&	STATE ROADS COMMISSION OF MARYLAND INTERSTATE DIVISION FOR BALTIMORE CITY
		INTERSTATE ROUTE 95 EASTERN AVENUE INTERCHANGE		DRAWN BY: JJK CHECKED BY: JJK DES. BY: JGC CHECKED BY: HEL F.A.P. NO. I-95-4(32)36 S.R.C. NO. BC 246-29-815 BALTO. CITY NO. 1959
		SCALE	DATE	SHEET NO. 110 of 113
			6-3-70	

SUMMARY OF QUANTITIES

SHEET NO. 113 OF 113
DATE: 6-3-70

ITEM NO	DESCRIPTION	UNIT	QUANTITY BRT FORWARD	TOTAL	PROPOSAL QUANTITY
CATEGORY NO. 1 LUMP SUM ITEMS					
101	Clearing & Grubbing	L.S.		L.S.	L.S.
102	Removal & Disposal of Existing Buildings	L.S.		L.S.	L.S.
103	Engineers Facilities	L.S.		L.S.	L.S.
104	Maintenance of Traffic	L.S.		L.S.	L.S.
105	Construction Stakeout	L.S.		L.S.	L.S.
106	Mobilization	L.S.		L.S.	L.S.
CATEGORY NO. 2 GRABING					
201	Class 1 Excavation	C.Y.	459,925	459,925	459,000
202	Class 1A Excavation	C.Y.	4,000	4,000	4,000
203	Class 2 Excavation	C.Y.	1,768	1,768	1,800
204	Contingent Borrow Excavation	C.Y.	4,400	4,400	4,400
205	Test Pit Excavation	C.Y.		50	50
206	Removal of Existing Concrete Curb & Gutter	L.F.	73	73	73
207	Removal of Existing Sidewalk	S.Y.	37	37	37
208	Removal of Existing Masonry	C.Y.	22	22	25
CATEGORY NO. 3 DRAINAGE ITEMS					
301	Class 3 Excavation for Incidental Construction	C.Y.		50	50
302	Trimming Existing Ditches	L.F.	150	150	150
303	* Selected Backfill Using No. 5 Aggregate	C.Y.		25	25
304	* Selected Backfill Using CR-6	C.Y.		25	25
305	15" R.C. Pipe Class 4	L.F.	140	140	140
306	18" R.C. Pipe Class 4	L.F.	3042	3042	3042
307	21" R.C. Pipe Class 4	L.F.	520	520	520
308	24" R.C. Pipe Class 4	L.F.	546	546	546
309	30" R.C. Pipe Class 4	L.F.	292	292	292
310	36" R.C. Pipe Class 4	L.F.	1096	1096	1096
311	42" R.C. Pipe Class 4	L.F.	400	400	400

ITEM NO	DESCRIPTION	UNIT	QUANTITY BRT FORWARD	TOTAL	PROPOSAL QUANTITY
CATEGORY NO. 3 DRAINAGE ITEMS (CONTINUED)					
312	48" R.C. Pipe Class 4	L.F.	1212	1212	1,212
313	54" R.C. Pipe Class 4	L.F.	640	640	640
314	60" R.C. Pipe Class 4	L.F.	556	556	556
315	18" R.C. Pipe Class 5	L.F.	88	88	88
316	42" R.C. Pipe Class 5	L.F.	404	404	404
317	18" B.C.C.M. Pipe Type 'A' No. 12 Gauge	L.F.	148	148	148
318	18" B.C.C.M. Pipe Type 'C' No. 14 Gauge	L.F.	758	758	758
319	18" B.C.C.M. Pipe Type 'D' No. 12 Gauge	L.F.	1152	1152	1152
320	24" B.C.C.M. Pipe Type 'C' No. 14 Gauge	L.F.	268	268	268
321	24" B.C.C.M. Pipe Type 'D' No. 12 Gauge	L.F.	974	974	974
322	42" B.C.C.M. Pipe Type 'D' No. 8 Gauge	L.F.	384	384	384
323	22" x 15" B.C.C.M. Pipe Arch Type 'A' 12 Gauge	L.F.	92	92	92
324	30" V.C. Pipe Extra Strength	L.F.	24	24	24
325	30" x 15" Pipe Connection Brick Y	Ea	1	1	1
326	18" x 18" Pipe Connection Brick Y	Ea	2	2	2
327	21" x 18" Pipe Connection Brick Y	Ea	1	1	1
328	24" x 18" Pipe Connection Brick Y	Ea	1	1	1
329	30" x 18" Pipe Connection Brick Y	Ea	3	3	3
330	36" x 18" Pipe Connection Brick Y	Ea	11	11	11
331	42" x 18" Pipe Connection Brick Y	Ea	4	4	4
332	48" x 21" Pipe Connection Brick Y	Ea	1	1	1
333	50" Pipe Connection Brick Curve	Ea	1	1	1
334	56" Pipe Connection Brick Curve	Ea	2	2	2
335	48" Pipe Connection Brick Curve	Ea	7	7	7
336	64" Pipe Connection Brick Curve	Ea	2	2	2
337	60" Pipe Connection Brick Curve	Ea	1	1	1
338	Removal of Old Pipe Divers, Any Size	L.F.	1854	1854	1854

* Contingent Item

ITEM NO	DESCRIPTION	UNIT	QUANTITY BRT FORWARD	TOTAL	PROPOSAL QUANTITY
CATEGORY NO. 3 DRAINAGE ITEMS (CONTINUED)					
339	Standard End Support Wall for 42" Pipe	Ea	1	1	1
340	Standard B 54 Headwall	Ea	1	1	1
341	Special B Headwall	Ea	1	1	1
342	Standard Type 'C' Endwall for 42" Pipe	Ea	2	2	2
343	Standard Type 'K' Inlet Single Grate - Minimum Depth	Ea	11	11	11
344	Standard Type 'K' Inlet Double Grate - Tandem Min. Depth	Ea	10	10	10
345	Standard Type 'K' Inlet Single Grate - Vertical Depth	L.F.	14.90	14.90	15.00
346	Standard Type 'K' Inlet Double Grate - Tandem Vert. Depth	L.F.	10.46	10.46	11.00
347	Standard Type 'S' Inlet Double Grate - Tandem Min. Depth	Ea	3	3	3
348	Standard Type 'S' Inlet Double Grate - Tandem Vert. Depth	L.F.	3.52	3.52	4.00
349	Standard Type 'S' Comb. Inlet Double Grate - Tandem Minimum Depth	Ea	30	30	30
350	Standard Type 'S' Comb. Inlet Double Grate - Tandem Vertical Depth	L.F.	62.28	62.28	63.00
351	Modified Type 'S' Comb. Inlet Double Grate - Tandem Minimum Depth	Ea	63	63	63
352	Modified Type 'S' Comb. Inlet Double Grate - Tandem Vertical Depth	L.F.	110.61	110.61	111.00
353	Adjust Existing Inlet	Ea	3	3	3
354	Drop Manhole 24" Cover - Minimum Depth	Ea	5	5	5
355	Drop Manhole 30" Cover - Minimum Depth	Ea	1	1	1
356	Drop Manhole, Vertical Depth	L.F.	61.87	61.87	62.00
357	Standard Stone Water Manhole, 24" Cover - Min. Depth	Ea	6	6	6
358	Standard Stone Water Manhole, 30" Cover - Min. Depth	Ea	17	17	17
359	Standard Stone Water Manhole - Vertical Depth	L.F.	79.00	79.00	79.00
360	Adjust Existing Manhole	Ea	5	5	5
361	Ordinary Brick Masonry for Miscellaneous Structures	C.Y.	1.0	1.0	1.0
362	Utility Trench Underdrain	L.F.		30	30
363	6" Perforated Capsular Pipe Longitudinal Underdrain	L.F.	13,501	13,501	13,500

REVISIONS	CONSULTANT	CITY OF BALTIMORE DEPARTMENT OF PUBLIC WORKS	STATE ROADS COMMISSION OF MARYLAND INTERSTATE DIVISION FOR BALTIMORE CITY
	KNOERLE, BENDER, STONE & ASSOC., INC. 141 N. CALVERT STREET BALTIMORE, MARYLAND 21202	INTERSTATE ROUTE 95 EASTERN AVENUE INTERCHANGE	DRAWN BY: ACB CHECKED BY: JCB DES. BY: V.F.H. CHK. BY: J.E.S.
		SCALE: NONE	DATE: 6-3-70
			SHEET NO. 113 OF 113

SUMMARY OF QUANTITIES

PROJ. NO.	STATE	FED. AID PROJ. NO.	SHEET NO.	TOTAL SHEETS
2	MD	1-95-4(32)36	112	143

ITEM NO	DESCRIPTION	UNIT	QUANTITY BRT FORWARD	TOTAL	PROPOSAL QUANTITY
CATEGORY NO. 3 DRAINAGE ITEMS (CONTINUED)					
364	6" Perforated Circular Pipe Underdrain	L.F.	---	11,300	11,300
365	8" Perforated Circular Pipe Underdrain	L.F.	---	900	900
366	6" Circular Pipe Underdrain Outlets	L.F.	840	840	840
367	8" Circular Pipe Underdrain Outlets	L.F.	---	180	180
368	Aggregate Backfill for Underdrains	C.Y.	390	390	400
369	5" Concrete Gutter	S.Y.	1880	1880	1880
370	Slope Protection for Stream, Using 5" Class B-1 Concrete	S.Y.	42	42	42
371	Class 1 Medium Riprap	S.Y.	221	221	225
372	Special Structure No. 1 - Bellmouth	L.S.	---	L.S.	L.S.
373	Special Structure No. 2 - Bellmouth	L.S.	---	L.S.	L.S.
374	Special Structure No. 3 - Bellmouth	L.S.	---	L.S.	L.S.
375	Special Structure No. 4 - Bellmouth	L.S.	---	L.S.	L.S.
376	Special Structure No. 5 - Bellmouth	L.S.	---	L.S.	L.S.
377	End Section for 18" C.M. Pipe	Ea.	9	9	9
378	End Section for 24" C.M. Pipe	Ea.	6	6	6
379	End Section for 22" x 13" C.M. Pipe Arch	Ea.	2	2	2
380	End Section for 18" R.C. Pipe	Ea.	1	1	1
381	End Section for 24" R.C. Pipe	Ea.	2	2	2
382	22° 30' Elbow - 18" B.C.C.M. Pipe, Type 'C' #14 Gauge	Ea.	16	16	16
383	30° Elbow - 18" B.C.C.M. Pipe, Type 'C' #14 Gauge	Ea.	2	2	2
384	22° 30' Elbow - 24" B.C.C.M. Pipe, Type 'C' #14 Gauge	Ea.	4	4	4
385	30° Elbow - 24" B.C.C.M. Pipe, Type 'C' #12 Gauge	Ea.	6	6	6
386	22° 30' Elbow - 18" R.C. Pipe, Class 4	Ea.	4	4	4
387	30° Elbow - 18" R.C. Pipe, Class 4	Ea.	2	2	2
388	45° Elbow - 18" R.C. Pipe, Class 4	Ea.	2	2	2
389	30° Elbow - 21" R.C. Pipe, Class 4	Ea.	2	2	2
390	Jacked 50" R.C. Pipe	L.S.	---	L.S.	L.S.
391	Jacked 54" R.C. Pipe	L.S.	---	L.S.	L.S.

ITEM NO	DESCRIPTION	UNIT	QUANTITY BRT FORWARD	TOTAL	PROPOSAL QUANTITY
CATEGORY NO. 4 STRUCTURES					
401	Class 3 Excavation	C.Y.	---	6440	6440
402	Subfoundation Drilling	L.F.	---	130	130
403	Footing Concrete	C.Y.	---	935	935
404	Substructure Concrete	L.S.	---	L.S.	L.S.
405	Superstructure Concrete	L.S.	---	L.S.	L.S.
406	Contingent Concrete for Bridges	C.Y.	---	10	10
407	Class 'C' Concrete for Subfoundation	C.Y.	---	10	10
408	Prestressing Cast In Place Concrete	L.S.	---	L.S.	L.S.
409	Pedestrian Protective Barrier	L.S.	---	L.S.	L.S.
410	Stone Filled Wire Mattress Slope Protection	S.Y.	---	1450	1450
411	Footing Concrete for Retaining Wall from Sta. 17+35 to Sta. 21+06	C.Y.	---	177	177
412	Footing Concrete for Retaining Wall from Sta. 330+00 to Sta. 331+00	C.Y.	---	215	215
413	Stem Concrete for Retaining Wall from Sta. 17+35 to Sta. 21+06	L.S.	---	L.S.	L.S.
414	Stem Concrete for Retaining Wall from Sta. 330+00 to Sta. 331+00	L.S.	---	L.S.	L.S.
415	Contingent Concrete for Reinforced Concrete Retaining Wall	C.Y.	---	15	15
CATEGORY NO. 5 PAVEMENT ITEMS					
501	6" Sub-Base, Using Crusher Run	S.Y.	28,072	28,072	28,100
502	7" Sub-Base, Using Crusher Run	S.Y.	42,404	42,404	42,410
503	3" Dense Graded Stabilized Aggregate Base Course	S.Y.	21,783	21,783	21,800
504	Calcium Chloride for 3" Dense Graded Stabilized Aggregate	S.Y.	39,483	39,483	39,500
505	Calcium Chloride for 4" Dense Graded Stabilized Aggregate	S.Y.	10,392	10,392	10,400
506	Calcium Chloride for 7" Dense Graded Stabilized Aggregate	S.Y.	6,613	6,613	6,620
Contingent Item					

ITEM NO	DESCRIPTION	UNIT	QUANTITY BRT FORWARD	TOTAL	PROPOSAL QUANTITY
CATEGORY NO. 5 PAVEMENT ITEMS (CONTINUED)					
507	Calcium Chloride for Variable Depth Dense Graded Stabilized Aggregate	S.Y.	13,566	13,566	13,570
508	3" Dense Graded Stabilized Aggregate Base Course with Asphalt Emulsion or Cement	S.Y.	18,234	18,234	18,250
509	Crusher Run Aggregate for Maintenance of Traffic	Ton	---	100	100
510	Bituminous Material for Prime Coat	Gal	10,467	10,467	10,470
511	Bituminous Concrete, Spec. 'B' for Wedge and/or Leveling Course	Ton	1,915	1,915	1,920
512	Bituminous Concrete, Spec. 'B' Using Band PF-1 Stone	Ton	278	278	280
513	Bituminous Concrete, Spec. 'B' Using Band PF-1 Slag	Ton	499	499	500
514	Bituminous Concrete, Spec. 'B' Using Band PC-1 61/Stone	Ton	107	107	110
515	Bituminous Concrete, Spec. 'B' Using Band PC-1 61/Slag	Ton	100	100	100
516	Bituminous Concrete, Spec. 'B' Using Band P-3	Ton	1,116	1,116	1,120
517	Bituminous Concrete, Spec. 'B' Using Band P-3 SL	Ton	1,805	1,805	1,810
518	Bituminous Concrete, Spec. 'B' for Maintenance of Traffic Stone/Slag	Ton	---	50	50
519	7" Plain Cement Concrete Pavement, C1. P	S.Y.	168	168	170
520	8" Reinforced Cement Concrete Pavement, C1. P	S.Y.	1,898	1,898	1,900
521	9" Reinforced Cement Concrete Pavement, C1. P	S.Y.	24,627	24,627	24,630
522	8" Continuous Reinforced Cement Pavement C1. P	S.Y.	41,200	41,200	41,200
523	Special Longitudinal Tie Bar Device	Ea.	359	359	350
524	Terminal Joints	L.F.	192	192	200
525	Calcium Chloride	Ton	---	5	5
CATEGORY NO. 6 SHOULDERS					
601	3" Stabilized Shoulders, Dense Graded Stabilized Aggregate	S.Y.	17,700	17,700	17,700
602	4" Stabilized Shoulders, Dense Graded Stabilized Aggregate	S.Y.	19,392	19,392	19,400
603	7" Stabilized Shoulders, Dense Graded Stabilized Aggregate	S.Y.	6,613	6,613	6,620
604	Variable Depth Stabilized Shoulder, Dense Graded Stabilized Aggregate	S.Y.	13,566	13,566	13,570

REVISIONS	CONSULTANT	CITY OF BALTIMORE DEPARTMENT OF PUBLIC WORKS	STATE ROADS COMMISSION OF MARYLAND INTERSTATE DIVISION FOR BALTIMORE CITY
	KNOX, BENDER, STONE & ASSOC., INC. MARY, CHILDS & ASSOC., INC. CONSULTING ENGINEERS 141 N. CALVERT STREET BALTIMORE, MARYLAND 21202	INTERSTATE ROUTE 95 EASTERN AVENUE INTERCHANGE	DRAWN BY: A.C.B. CHECKED BY: M.C.B. F.A.P. NO. 1-95-4(32)36 S.R.C. NO. BC 246-24-815 BALD. CITY NO. 1050
		SCALE: NONE	DATE: 6-3-70

SUMMARY OF QUANTITIES

PROJECT NO. 2 MD 195 V-3236 113 113
 DATE 6-3-70

ITEM NO	DESCRIPTION	UNIT	QUANTITY BRT FORWARD	TOTAL	PROPOSAL QUANTITY
CATEGORY NO. 6 SHOULDERS (CONTINUED)					
605	Bituminous Concrete Shoulders, Spec. 'B' Band PC-1 61 Stone	Ton	3,349	3,349	3,350
606	Bituminous Concrete Shoulders, Spec. 'B' Band PC-1 61 Slag	Ton	3,115	3,115	3,115
607	Bituminous Concrete Shoulders, Bank Run Gravel Aggregate Band G-2	Ton	345	345	345
608	Standard Type 'A' Curb 8" x 12"	L.F.	7,377	7,377	7,380
609	Std. Type 'A' Comb. Curb & Gutter 12" Gutter Pan 8" Depth	L.F.	162	162	165
610	Std. Type 'A' Comb. Curb & Gutter 24" Gutter Pan 8" Depth	L.F.	5,758	5,758	5,760
611	Std. Type 'A' Comb. Curb & Gutter 12" Gutter Pan 9" Depth	L.F.	292	292	295
612	Std. Type 'A' Comb. Curb & Gutter 24" Gutter Pan 10" Depth	L.F.	251	251	255
613	Standard Curb Opening	Ea.	7	7	7
614	Standard Curb Opening for Curb & Gutter	Ea.	1	1	1
615	Monolithic Concrete Median Variable Width Type 'B' 4'-0" to 6'-0"	L.F.	151	151	151
616	Concrete Barrier	L.F.	14,824	14,824	14,825
617	10" Plain Cement Concrete Shoulder	S.Y.	6,589	6,589	6,590
618	5" Concrete Sidewalk	S.F.	15,344	15,344	15,345
619	Guard Rail W Beam	L.F.	1,713	1,713	1,713
620	Guard Rail W Beam Approach Flare	Ea.	6	6	6
621	7 Ft. Chain Link Fence with Barbed Wire	L.F.	5	5	5
622	Terminal Post for 7 Ft. Chain Link Fence	Ea.	1	1	1
623	Gate for Chain Link Fence	Ea.	2	2	2
624	Reset Existing Fence	L.F.	5	5	5
625	Removal of Existing Fence	L.F.	5	5	5
CATEGORY NO. 7 ROADSIDE IMPROVEMENT ITEMS					
701	Placing Salvaged Top Soil 2" Depth	S.Y.	83,466	83,466	83,470
702	Top Soil Furnished & Placed 2" Depth	S.Y.	15,942	15,942	15,990
703	Top Soil Furnished & Placed 4" Depth	S.Y.	2,391	2,391	2,400
704	Seeding & Mulching	S.Y.	99,408	99,408	99,420
705	Seeding & Mulching Flat Areas	S.Y.	2,391	2,391	2,400
706	Solid Seeding	S.Y.	5,766	5,766	5,770
707	Spur Cuts Milling	S.Y.	1,713	1,713	1,720
708	Soil Mix	C.Y.	2,535	2,535	2,550

ITEM NO	DESCRIPTION	UNIT	QUANTITY BRT FORWARD	TOTAL	PROPOSAL QUANTITY
709	Temporary Seeding	S.Y.	20,000	20,000	20,000
CATEGORY NO. 8 UTILITIES					
801	Roadway Pedestal Base 11" Bolt Circle	Ea.	35	35	35
802	3" Metallic Conduit and Fittings	L.F.	525	525	525
803	Hand Box for Mechanical Electrical Service	Ea.	26	26	26
804	Adjust Existing Hand Box	Ea.	11	11	11
805	Anchor Base Standard 12" Bracket Arm	Ea.	30	30	30
806	400 Watt Mercury Luminaire Built In Ballast and Auxiliary Equipment	Ea.	35	35	35
807	Removal & Remounting of Existing Lighting Standards	Ea.	5	5	5
808	Type M H Duct Section 2 - 3" 2W x 1H, 8 - 5" 2W x 4H	L.F.	240	240	240
809	Type M X Duct Section 2 - 3" 2W x 1H -	L.F.	220	220	220
810	Type M Y Duct Section 1 - 3"	L.F.	1,287	1,290	1,290
811	Type W Duct Section 3 - 4" I.D. Fibres	L.F.	46	50	50
812	Bridge Electrical Duct Section	L.F.	312	312	312
813	Type G Manhole - Mechanical Electrical	Ea.	2	2	2
814	Adjust Existing Manhole - Mechanical Electrical	Ea.	5	5	5
815	18" R.C. Pipe Class 4 (Sanitary)	L.F.	680	680	680
816	12" R.C. Pipe Class 5 (Sanitary)	L.F.	48	48	48
817	15" R.C. Pipe Class 5 (Sanitary)	L.F.	1,360	1,360	1,360
818	16" Cast Iron Pipe & Fittings	L.F.	112	112	112
819	16" Steel Pipe & Fittings	L.F.	360	360	360
820	6" Fire Hydrant & Valve	Ea.	2	2	2
821	16" Valve & Vault	Ea.	1	1	1
822	Class 'A' Concrete for Buttress & Anchors	C.Y.	18	20	20
823	Split Buttress - 16" Water Main	Ea.	2	2	2
824	Class 'B' Concrete for Encasement	C.Y.	62	62	62
825	Relocation of Water Service 3/4"	Ea.	2	2	2
826	Relocation of Water Service 10"	Ea.	1	1	1

Contingent Item

ITEM NO	DESCRIPTION	UNIT	QUANTITY BRT FORWARD	TOTAL	PROPOSAL QUANTITY
CATEGORY NO. 8 UTILITIES (CONTINUED)					
827	Abandoning Existing Water Service	Ea.	4	4	4
828	Abandoning Existing Fire Hydrant	Ea.	2	2	2
829	Adjust Water Vault Frame	Ea.	2	2	2
830	Adjust Valve Box Frame	Ea.	2	2	2
831	Standard San. Manhole, 24" Cover - Minimum Depth	Ea.	12	12	12
832	Standard San. Manhole, Vertical Depth	U.F.	126.70	127.00	127.00
833	Type 'A' Sanitary Drop Connection	Ea.	1	1	1
834	Adjust Existing Manhole (Sanitary)	Ea.	3	3	3
835	Mast Arm Traffic Signal Support Pedestal Foundations	Ea.	13	13	13
836	Mast Arm Traffic Signal Support	Ea.	8	8	8
837	Furnish & Installation of Vehicle Detectors	L.S.	1.5	1.5	1.5
838	Automatic Control of Traffic Signal at Eastern Avenue Detour Road	L.S.	1.5	1.5	1.5
839	Remove Existing Track	L.F.	355	355	355
840	Railroad Grade Crossing	L.S.	1.5	1.5	1.5

REVISIONS	CONSULTANT KNOERLE, BENDER, STONE & ASSOC., INC. AND MATZ, CHILDS & ASSOC., INC. CONSULTING ENGINEERS 341 N. CALVERT STREET BALTIMORE, MARYLAND 21202	CITY OF BALTIMORE DEPARTMENT OF PUBLIC WORKS	STATE ROADS COMMISSION OF MARYLAND INTERSTATE DIVISION FOR BALTIMORE CITY
		INTERSTATE ROUTE 95 EASTERN AVENUE INTERCHANGE	DRAWN BY: ABE CHECKED BY: J.C. DATE: 6-3-70 SCALE: NONE

FILE NO.	STATE	PROJECT NO.	SHEET NO.	TOTAL SHEETS
2	MD	1-95-4132136	12	113

BARRIER CURB TRANSITION

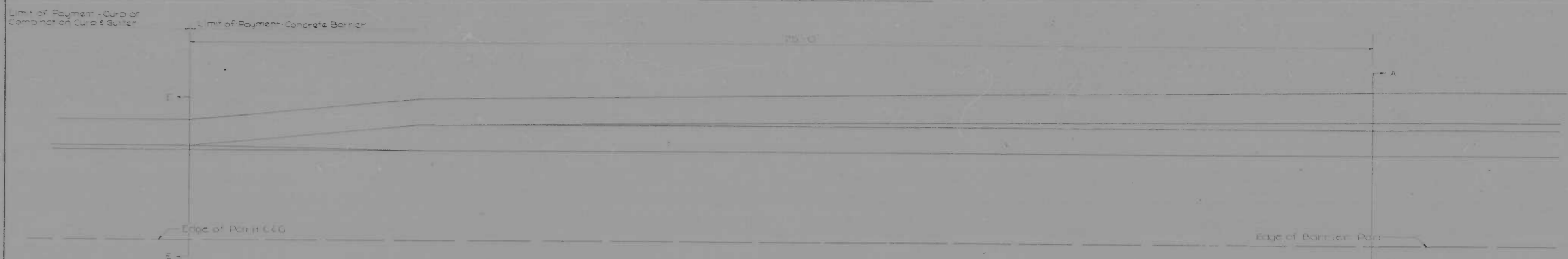

PLAN
Scale 1"=10'

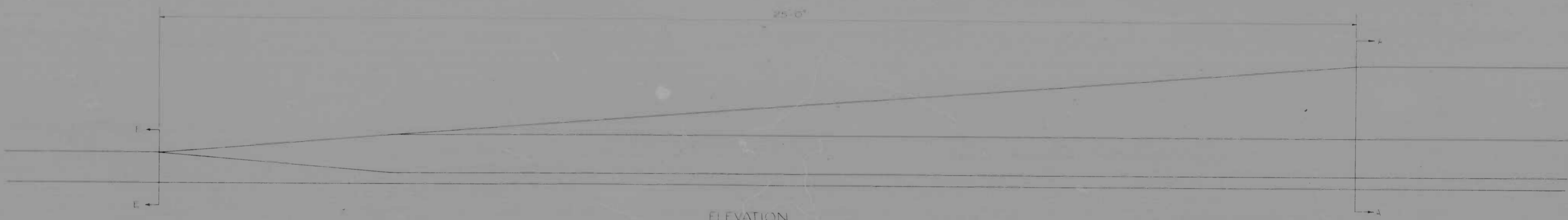

ELEVATION

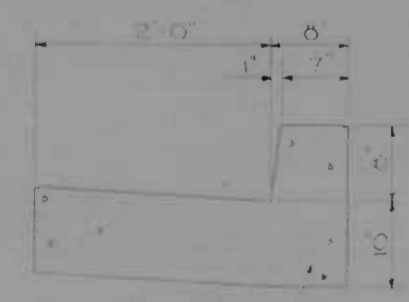

AND Type A Gable Curb & Gutter
(24" Curb, 10" Depth)

Section E-E

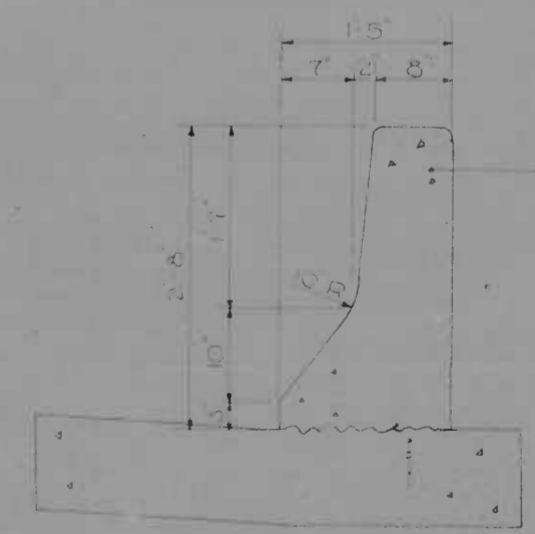

Section A-A

REVISIONS	CONSULTANT	CITY OF BALTIMORE DEPARTMENT OF PUBLIC WORKS	STATE ROADS COMMISSION OF MARYLAND INTERSTATE DIVISION FOR BALTIMORE CITY
	KWIERLE, BENDER, STONE & ASSOC., INC. AND MATZ, CHILDS & ASSOC., INC. CONSULTING ENGINEERS 341 N. CALVERT STREET BALTIMORE, MARYLAND 21202	& INTERSTATE ROUTE 95 EASTERN AVENUE INTERCHANGE	DRAWN BY: VEH TRACED BY: JDM E.A.P. NO. 1-95-4132136 S.P.C. NO. BC 246-29-915 BALTO. CITY NO. 1959
		SCALE: 1"=10'-0"	DATE: 4-20-70
			DES. BY: DES CHK. BY: VEH SHEET NO. 12 of 113

FED. ROAD DIST. NO.	STATE	FED. HIGHWAY NO.	SHEET NO.	TOTAL SHEETS
2	MD	100	13	12

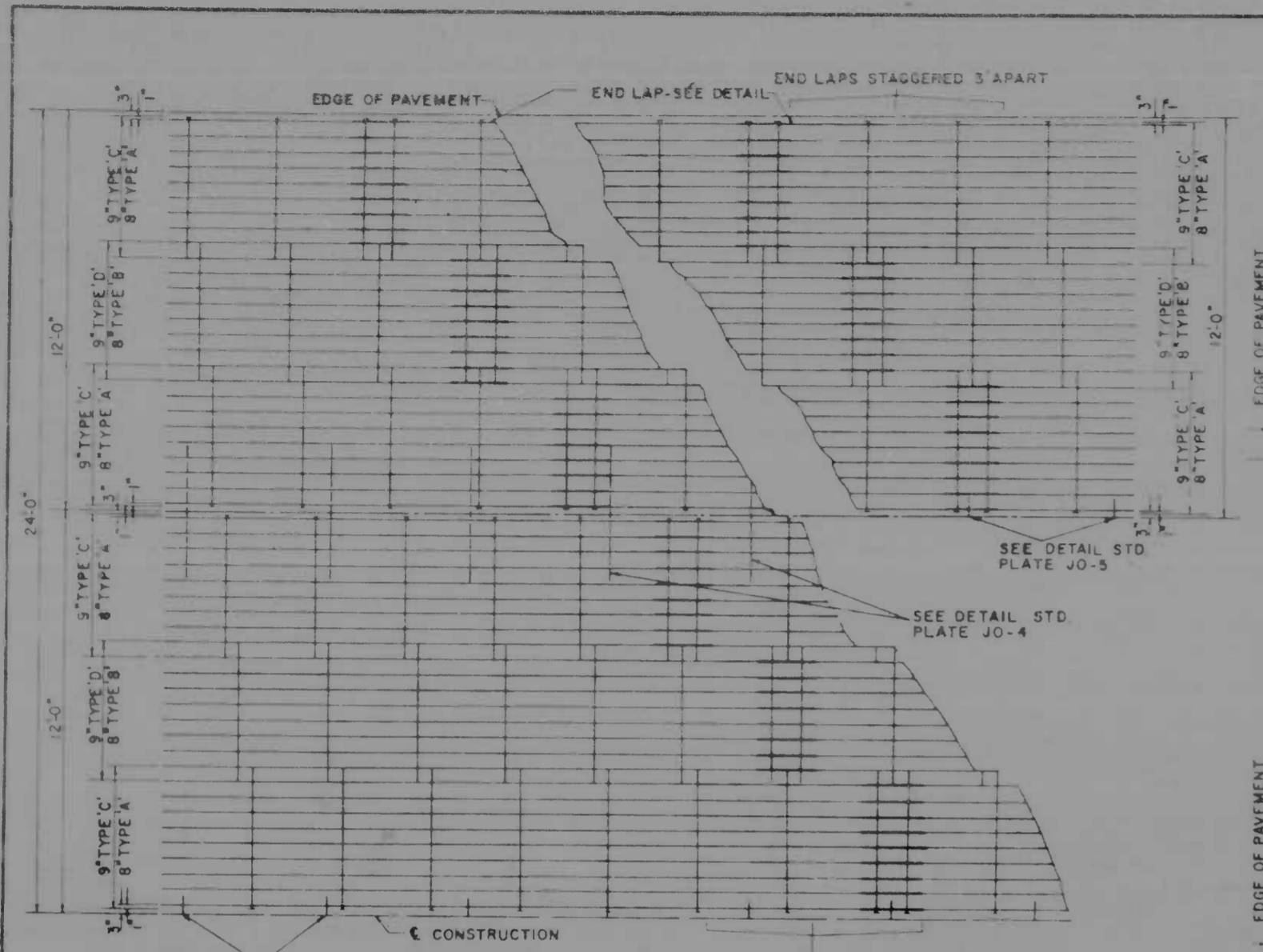

PLAN - BAR MATS
SCALE: 3/8" = 1'-0"
LENGTH OPTIONAL 35' MINIMUM

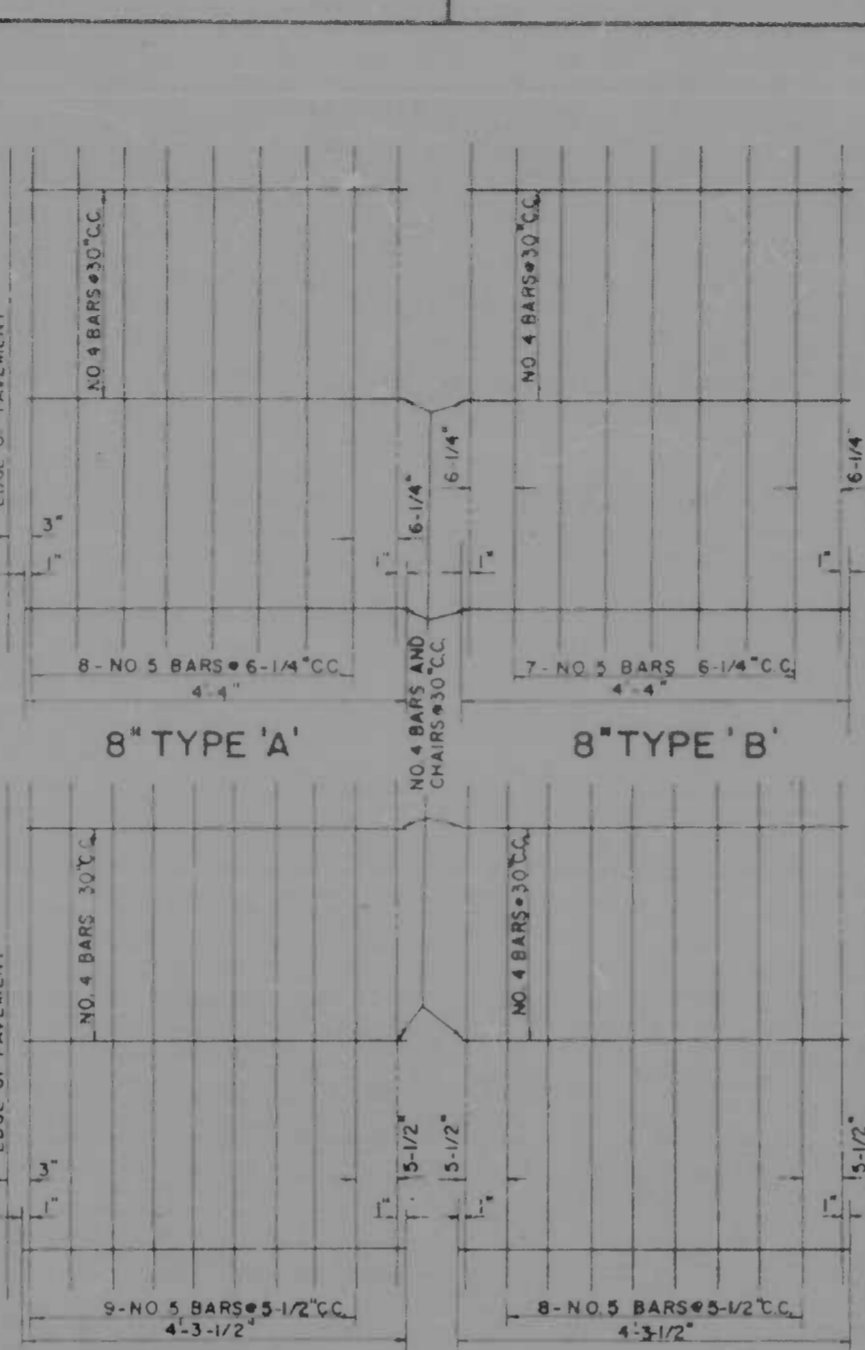

PLAN - LOOSE BARS
SCALE: 3/8" = 1'-0"

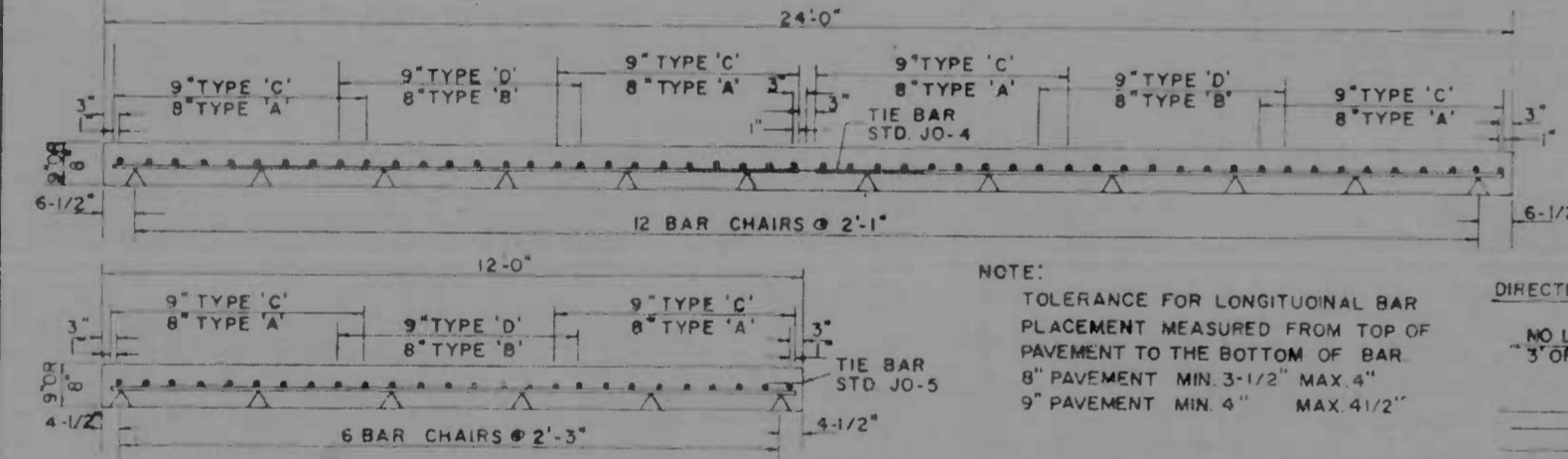

TRANSVERSE SECTION
SCALE: 1/2" = 1'-0"



BAR MAT DETAILS
SCALE: 3/4" = 1'-0"

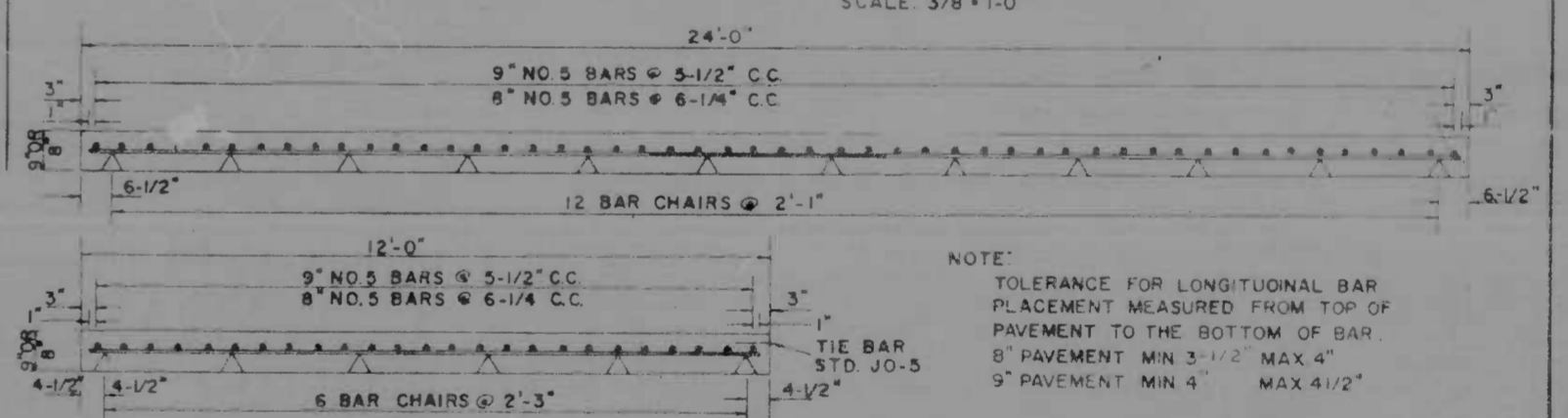

TRANSVERSE SECTION
SCALE: 1/2" = 1'-0"

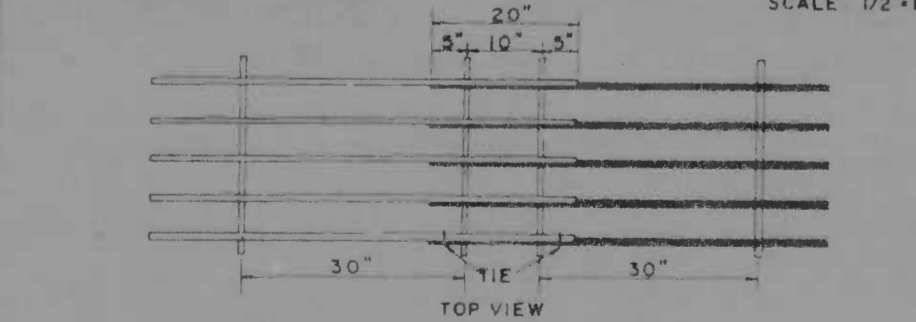

END LAP DETAIL
SCALE: 3/4" = 1'-0"



BULKHEAD JOINT AND LAP DETAIL
REINFORCEMENT ON CHAIRS
SCALE: 1/2" = 1'-0"

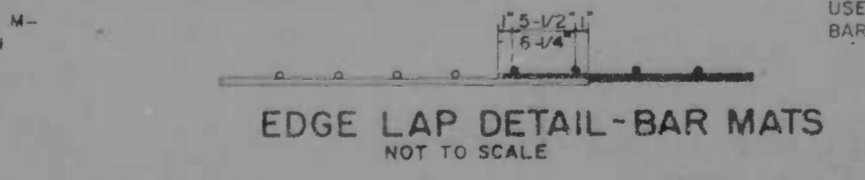

EDGE LAP DETAIL - BAR MATS
NOT TO SCALE

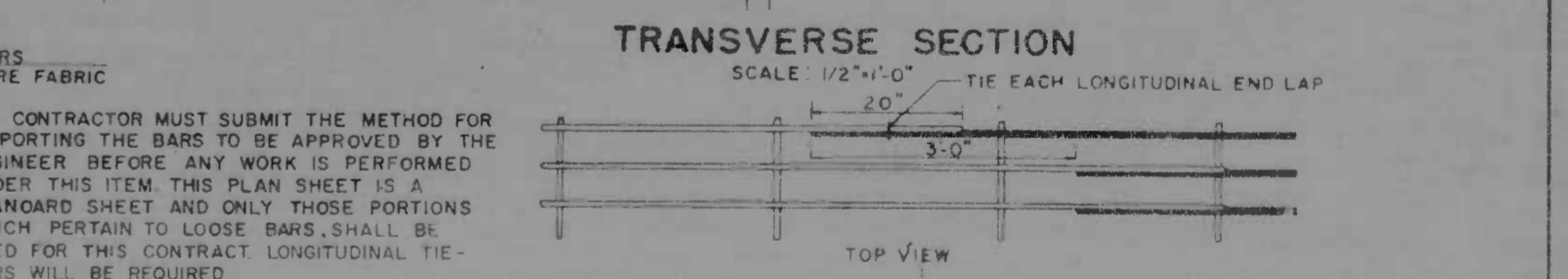

END LAP DETAIL
SCALE: 1/2" = 1'-0"

NOTE: TOLERANCE FOR LONGITUDINAL BAR PLACEMENT MEASURED FROM TOP OF PAVEMENT TO THE BOTTOM OF BAR:
8" PAVEMENT MIN 3-1/2" MAX 4"
9" PAVEMENT MIN 4" MAX 4-1/2"

NOTE: DEFORMED STEEL BARS FOR LONGITUDINAL AND TRANSVERSE BAR MATS AND LOOSE BARS SHALL MEET THE REQUIREMENTS OF A.A.S.H.O. DESIGNATION M-185 FOR NO. 5 BARS AND A.A.S.H.O. DESIGNATION M-31 FOR NO. 4 BARS. MATS TO BE SECURELY FASTENED TO PREVENT SEPARATION DURING CONCRETE PLACEMENT. MINIMUM 6 TIES EACH MAT.

NOTE: THE CONTRACTOR MUST SUBMIT THE METHOD FOR SUPPORTING THE BARS TO BE APPROVED BY THE ENGINEER BEFORE ANY WORK IS PERFORMED UNDER THIS ITEM. THIS PLAN SHEET IS A STANDARD SHEET AND ONLY THOSE PORTIONS WHICH PERTAIN TO LOOSE BARS, SHALL BE USED FOR THIS CONTRACT. LONGITUDINAL TIE-BARS WILL BE REQUIRED.

CONTINUOUSLY REINFORCED CONCRETE PAVT
BAR STEEL REINFORCEMENT

CITY OF BALTIMORE DEPARTMENT OF PUBLIC WORKS		STATE ROADS COMMISSION OF MARYLAND INTERSTATE DIVISION FOR BALTIMORE	
INTERSTATE ROUTE 95 EASTERN AVENUE INTERCHANGE		DRAWN BY TRACED BY	DES. BY CHK. BY
SCALE: AS SHOWN	DATE: 4-20-70	F.A.P. NO. 1-95-3(2)136 S.R.C. NO. 65-246-19-215 BALTO. CITY NO. 1000	SHEET NO. 13 OF 13

FILE NO.	STATE	PROJ. NO.	SHEET NO.	TOTAL SHEETS
2	MD	195-4-32136	14	113

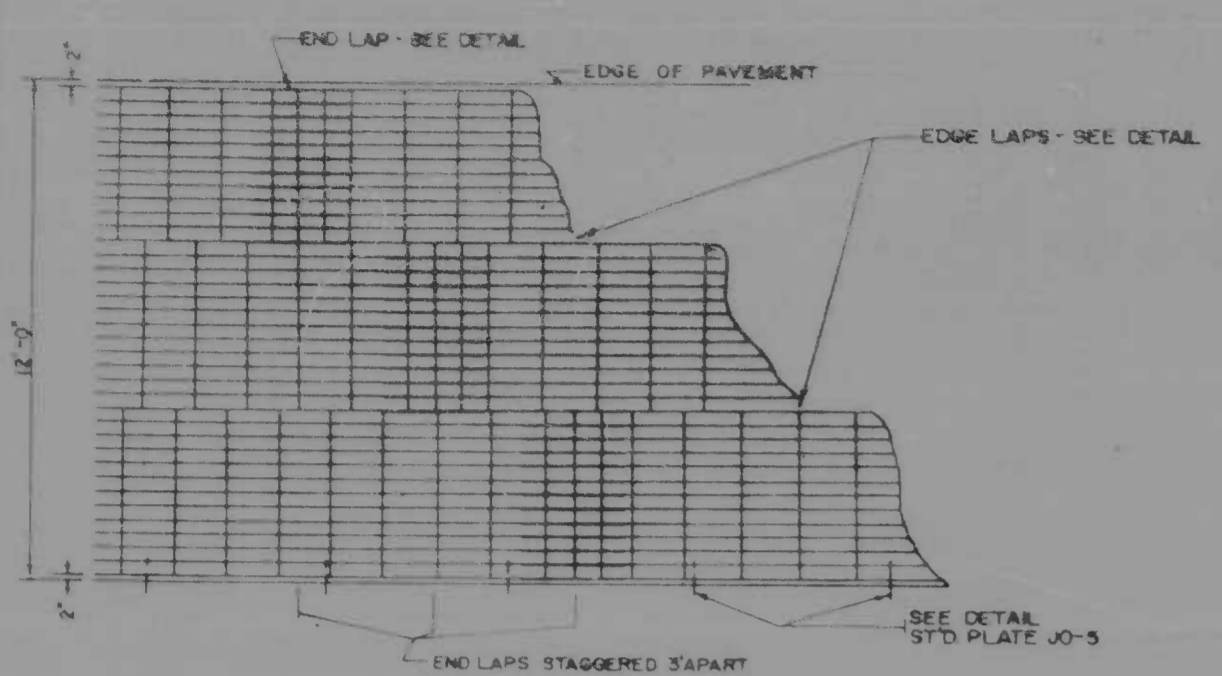

PLAN
SCALE 3/8" = 1'-0"

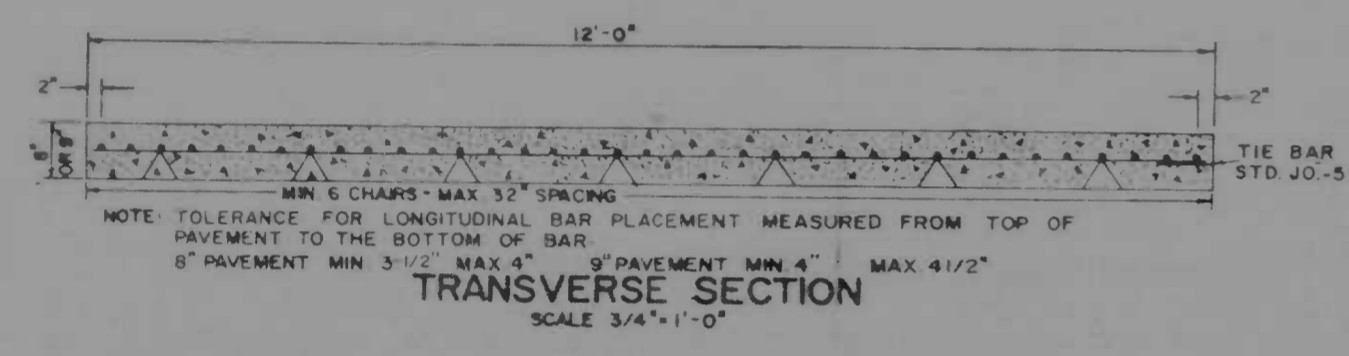

TRANSVERSE SECTION
SCALE 3/4" = 1'-0"

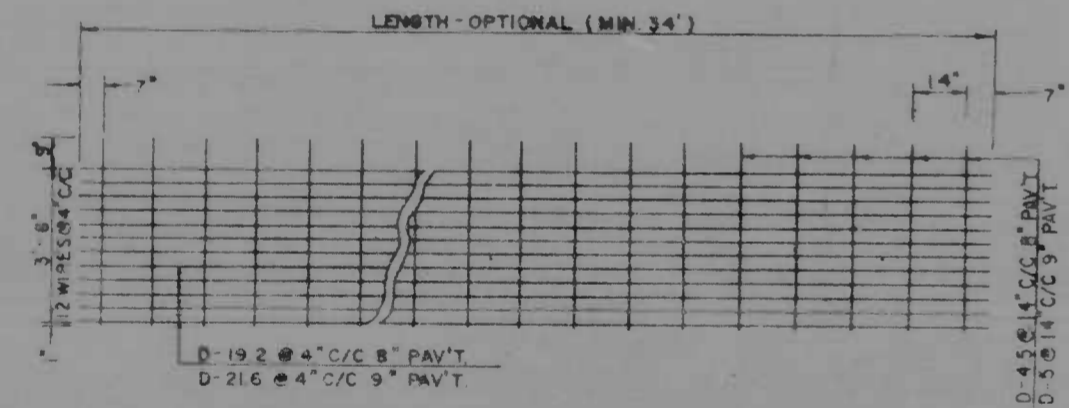

TYPICAL FABRIC SHEET
SCALE 3/8" = 1'-0"

NOTE: WELDED DEFORMED STEEL WIRE FABRIC FOR LONGITUDINAL AND TRANSVERSE WIRES SHALL MEET THE REQUIREMENTS OF A.S.T.M. DESIGNATION A-497 FOR WELDED DEFORMED STEEL WIRE FABRIC FOR CONCRETE REINFORCEMENT.

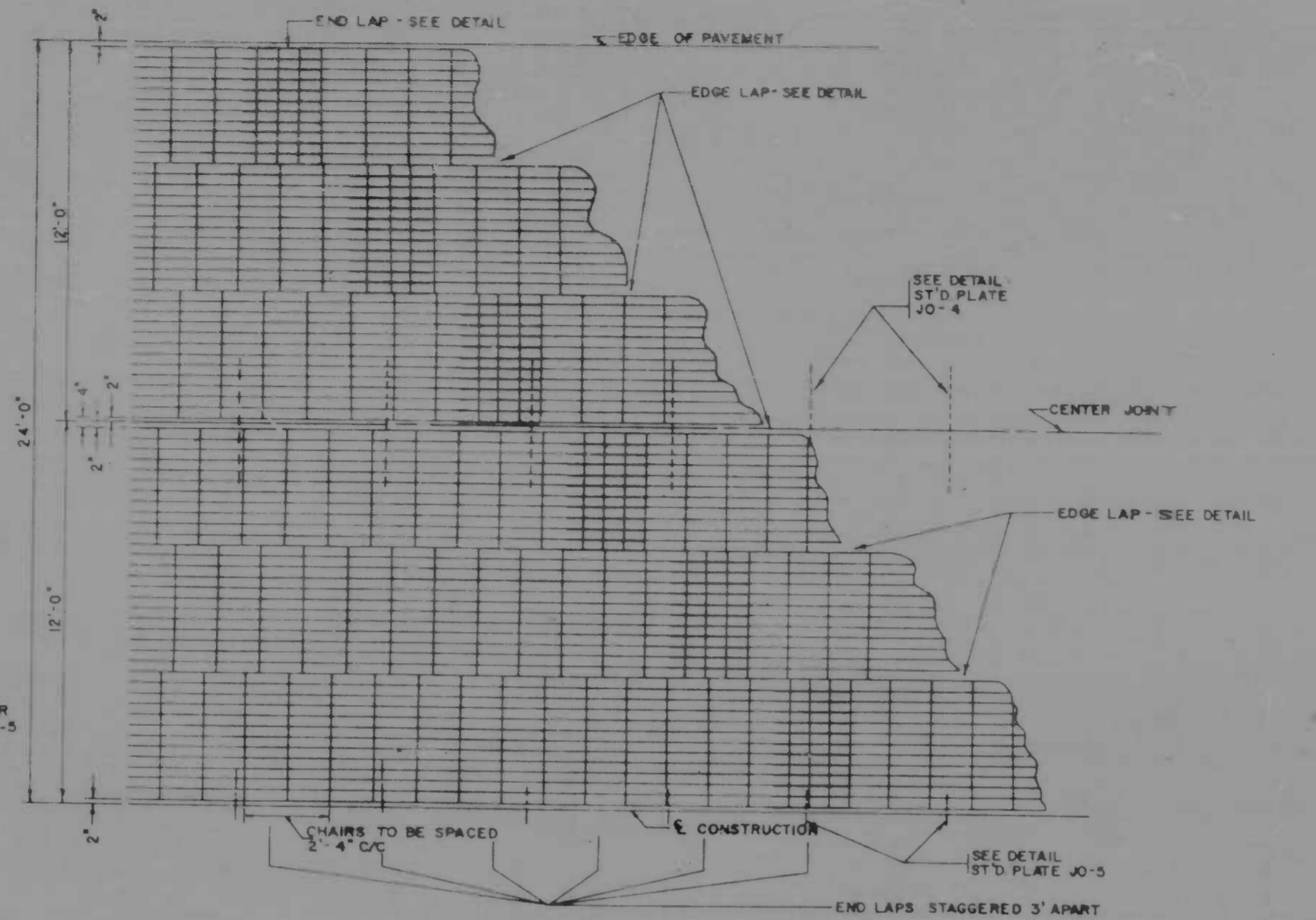

PLAN
SCALE 3/8" = 1'-0"

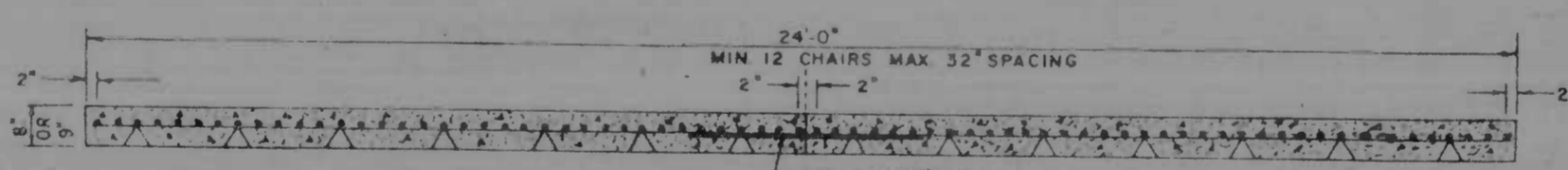

TRANSVERSE SECTION
SCALE 1/2" = 1'-0"

NOTE: TOLERANCE FOR LONGITUDINAL BAR PLACEMENT MEASURED FROM TOP OF PAVEMENT TO THE BOTTOM OF BAR. 8" PAVEMENT MIN 3-1/2" MAX 4" 9" PAVEMENT MIN 4" MAX 4-1/2"

NOTE: THE SHEET OF WELDED DEFORMED STEEL WIRE FABRIC WHEN PREPLACED SHALL BE SUPPORTED IN POSITION BY CHAIR SUPPORTS OF ANY TYPE SATISFACTORY AND CAPABLE OF PROVIDING ADEQUATE SUPPORT, AND THE CONCRETE PLACED THROUGH THE OPENINGS. SHEETS OF WELDED DEFORMED STEEL WIRE FABRIC MAY BE PLACED WITH THE TRANSVERSE WIRES UP OR DOWN.

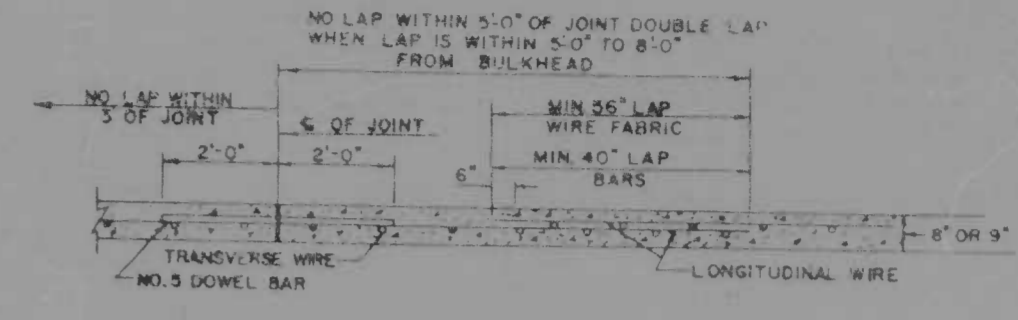

DOWELS AT TRANSVERSE CONSTRUCTION JOINTS NO. 5 DOWEL BAR TO BE PLACED MIDWAY BETWEEN LONGITUDINAL BAR AND THEN SPACED ON 12" C/C FOR WIRE FABRIC, ON 11" AND 12-1/2" C/C FOR BAR AND BAR MATS.

BULKHEAD JOINT AND LAP DETAIL
REINFORCEMENT BY MECHANICAL MEANS
SCALE 1/2" = 1'-0"

WHEN THE OPTION OF PLACING REINFORCEMENT BY MECHANICAL MEANS IS USED THE BAR OR WIRE FABRIC MATS SHALL BE DOUBLE LAPPED AS SHOWN ABOVE.
WHEN THE OPTION OF PLACING REINFORCEMENT ON CHAIRS OR CHAIR BARS IS USED THE BAR OR WIRE FABRIC MATS SHALL BE LAPPED AS SHOWN ON SHEET NO. 13.

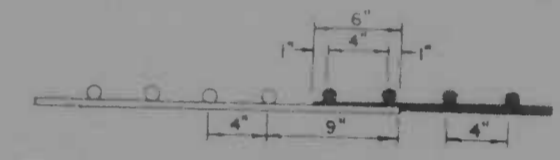

EDGE LAP DETAIL
SCALE 1/2" = 1'-0"

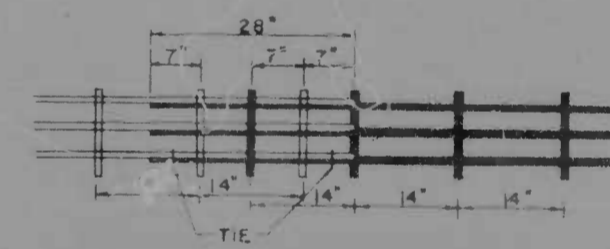

END LAP DETAIL
SCALE 3/4" = 1'-0"

NOTE: MATS TO BE SECURELY FASTENED TO PREVENT SEPARATION DURING CONCRETE PLACEMENT. MINIMUM 6 TIES EACH MAT.

NOTE: FOR JOINT DETAILS SEE SHEET NO. 15

THE CONTRACTOR MUST SUBMIT THE METHOD FOR SUPPORTING THE BARS TO BE APPROVED BY THE ENGINEER BEFORE ANY WORK IS PERFORMED UNDER THIS ITEM. THIS PLAN SHEET IS A STANDARD SHEET AND ONLY THOSE PORTIONS WHICH PERTAIN TO LOOSE BARS SHALL BE USED FOR THIS CONTRACT.

CONTINUOUSLY REINFORCED CONCRETE PAVEMENT
WELDED DEFORMED STEEL WIRE FABRIC REINFORCEMENT

CITY OF BALTIMORE DEPARTMENT OF PUBLIC WORKS		STATE ROADS COMMISSION OF MARYLAND INTERSTATE DIVISION FOR BALTIMORE	
INTERSTATE ROUTE 95 EASTERN AVENUE INTERCHANGE		DRAWN BY TRACED BY	DES. BY CHK. BY
SCALE: As Shown	DATE: 4/20/70	F.A.P. NO. 7-36-5-2013C S.R.C. NO. 86-441-23-105 BALTO. CITY NO. 1052	SHEET NO. 14 of 113



TERMINAL JOINT LAYOUT
NOT TO SCALE

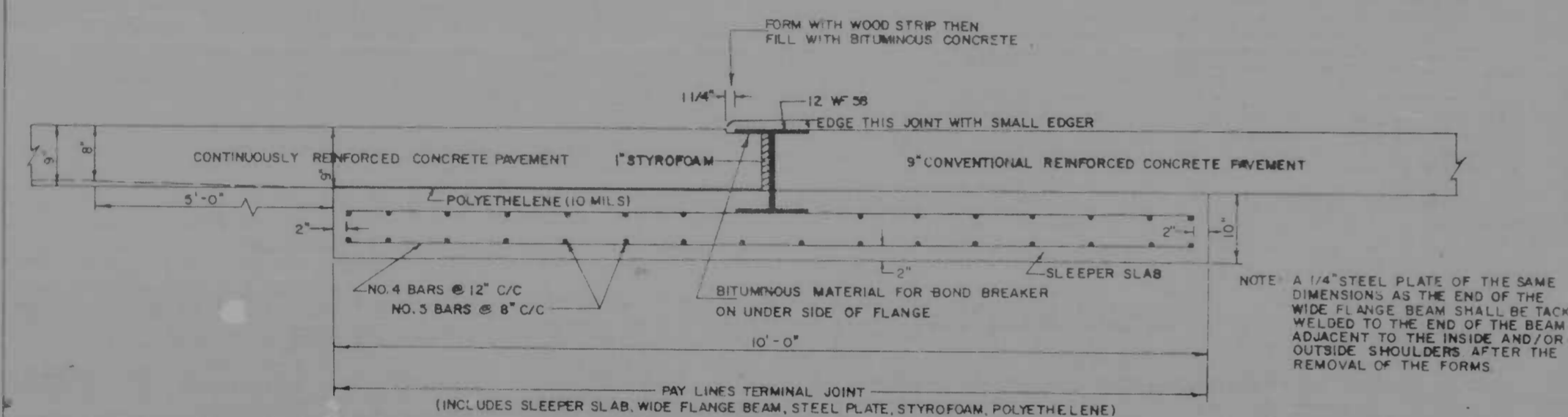

DETAIL 'A'
SLEEPER SLAB AND WIDE FLANGE TERMINAL JOINT *
SCALE: 1" = 1'-0"

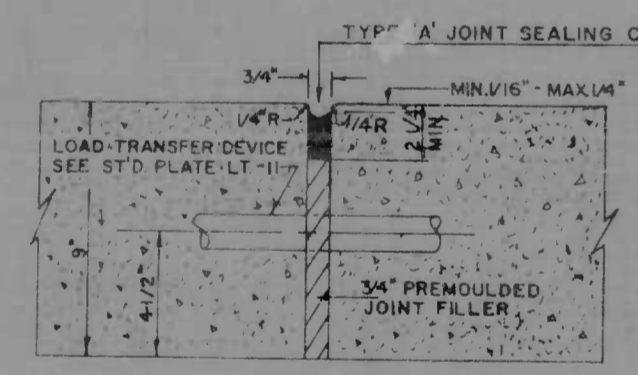

EXPANSION JOINT DETAIL 'B'
SCALE: 3" = 1'-0"

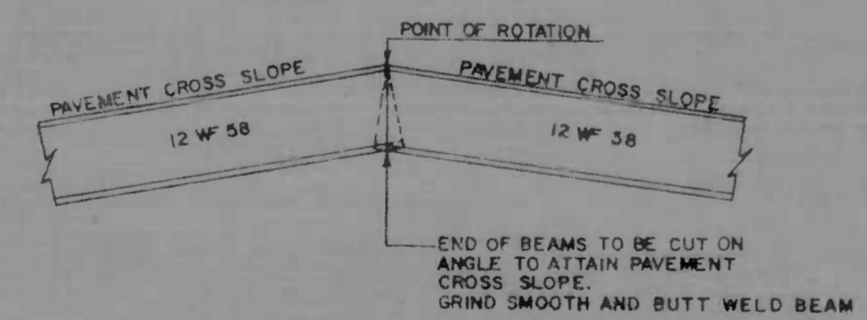

WIDE FLANGE BEAM ANGLE TIE
NOT TO SCALE

TERMINAL JOINT
BAR MATS, BARS, WIRE FABRIC

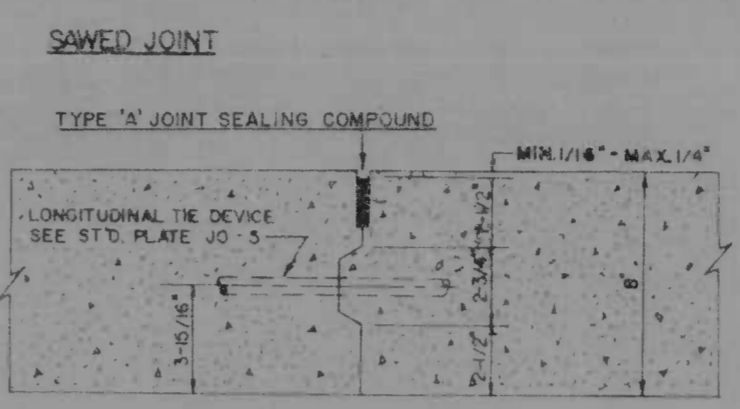

LONGITUDINAL CONSTRUCTION JOINT FOR 12' WIDTH PAVING WITH 8" CONTINUOUSLY REINFORCED CONCRETE PAVEMENT

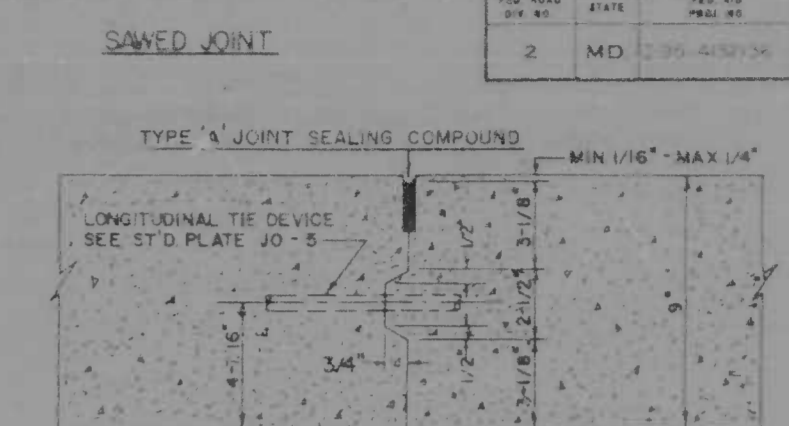

LONGITUDINAL CONSTRUCTION JOINT FOR 12' WIDTH PAVING WITH 9" CONTINUOUSLY REINFORCED CONCRETE PAVEMENT

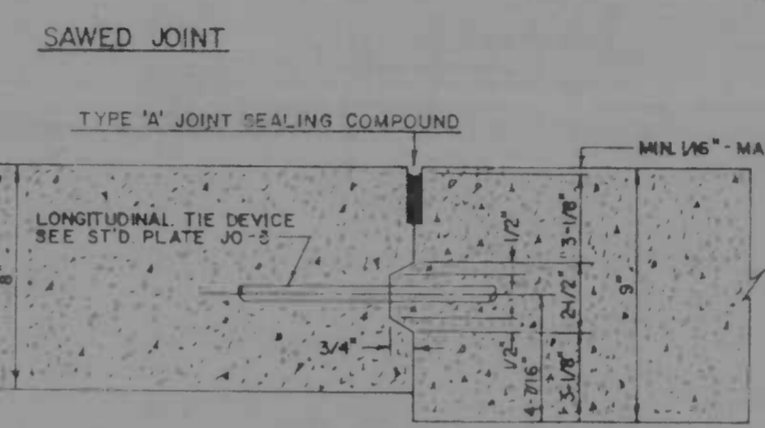

LONGITUDINAL CONSTRUCTION JOINT FOR 24' WIDTH PAVING WITH 8" AND 9" CONTINUOUSLY REINFORCED CONCRETE PAVEMENT

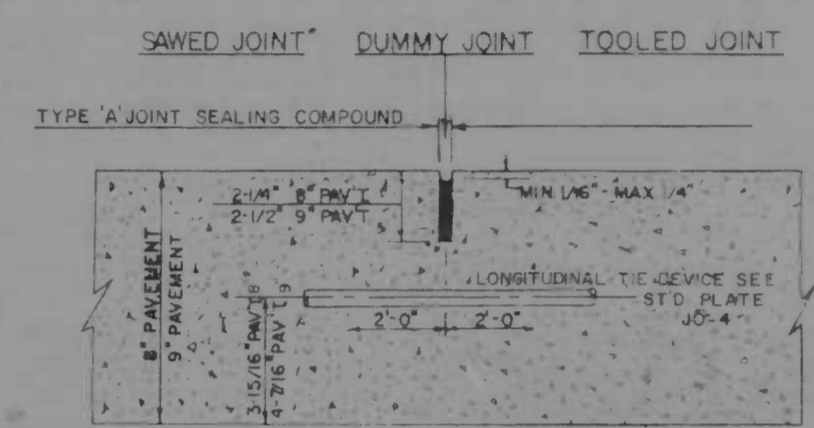

LONGITUDINAL CONSTRUCTION JOINT FOR 24' WIDTH PAVING WITH 8" OR 9" CONTINUOUSLY REINFORCED CONCRETE PAVEMENT AND/OR 9" CONVENTIONAL REINFORCED CONCRETE PAVEMENT. SAW JOINT IN 72 HOURS

DETAILS OF LONGITUDINAL CONSTRUCTION JOINTS
SCALE: 3" = 1'-0"

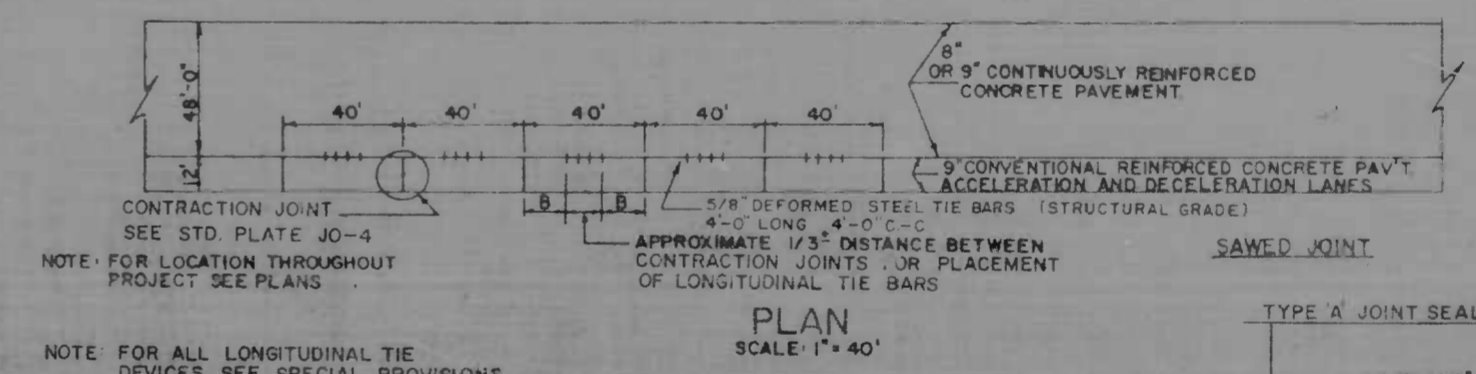

NOTE: FOR ALL LONGITUDINAL TIE DEVICES, SEE SPECIAL PROVISIONS.

PLAN
SCALE: 1" = 40'

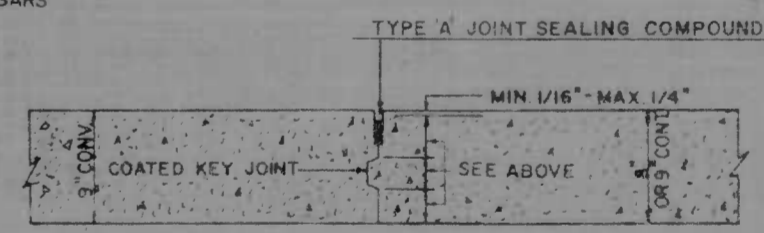

LONGITUDINAL KEY JOINT ('B' DISTANCE)
SCALE: 1 1/2" = 1'-0"

9" CONVENTIONAL REINFORCED CONCRETE PAVEMENT
ADJACENT TO 8" OR 9" CONTINUOUSLY REINFORCED CONCRETE PAVEMENT

CONTINUOUSLY REINFORCED CONCRETE PAVEMENT JOINT DETAILS

CITY OF BALTIMORE DEPARTMENT OF PUBLIC WORKS		STATE ROADS COMMISSION OF MARYLAND INTERSTATE DIVISION FOR BALTIMORE	
INTERSTATE ROUTE 95 EASTERN AVENUE INTERCHANGE		DRAWN BY TRACED BY F.A.P. NO. 1-95-91301-16 S.P.C. NO. BR. 2/95-23-85 BALTO. CITY NO. 1059	DES. BY CHK. BY SHEET 15 OF 113
SCALE AS SHOWN		DATE: 4/20/70	

REV. NO.	DATE	BY	CHK.	TOTAL SHEETS
2	MB	1-95-4132136	16	13

CURVE DATA

RAMP	CURVE NO.	Δ	D	R	T	L	E
A	A-1	99°03'35.1"	25°48'32"	222.00	260.21	363.62	120.04
A	A-2	90°00'00.0"	33°18'41"	172.00	172.00	270.18	7.24
A	A-3	85°08'18.4"	33°18'41"	172.00	157.90	235.48	8.44
A	A-4	9°07'46.6"	2°35'35"	2209.83	176.43	332.08	7.03
B	B-2	2°15'22"	5°10'00"	174.11	24.88	47.77	27.34
B	B-5	60°41'46.2"	1°59'12"	478.00	226.61	423.22	51.00
B	B-6	83°46'27.1"	5°17'45"	1000.00	88.68	146.21	34.33
B	B-7	75°13'44.8"	5°17'45"	1000.00	77.05	131.30	26.34
C	C-1	17°28'41.1"	4°9'26"	4000.00	97.80	19.83	11.78
C	C-2	90°00'00.0"	3°49'52"	1800.00	180.00	282.74	74.56
C	C-3	106°18'59.1"	3°49'52"	1800.00	240.25	334.00	120.20
C	C-4	30°02'15.5"	28°18'52"	200.00	53.66	104.85	7.07
C	C-5	20°10'49.2"	4°9'26"	4000.00	7.18	140.89	6.26
C	C-6	9°25'34.3"	7°09'43"	8000.00	55.56	19.61	2.71
D	D-1	3°45'59.2"	4°10'28.5"	1372.48	432.37	831.73	66.49
D	D-4	7°25'50.7"	2°00'00"	2064.79	186.35	372.37	6.06
D	D-5	45°37'55.9"	3°21'11.9"	178.00	21.29	32.55	13.73
D	D-6	18°55'48.2"	2°07'47"	328.00	38.01	78.33	3.15
D	D-7	8°07'50.7"	7°17'45"	100.00	84.10	139.85	35.56
D	D-8	4°53'06"	3°17'45"	100.00	51.93	95.79	12.58
D	D-9	35°26'54"	1°45'30"	50.00	13.82	30.64	2.44
E	E-1	88°53'13.3"	7°44'11"	232.00	84.35	127.10	8.23
E	E-2	69°11'22.9"	7°44'17.8"	320.00	220.71	385.43	68.73
E	E-3	35°16'27.3"	7°30'00"	189.72	173.70	347.17	35.5
F	F-1	80°20'00.0"	3°24'45"	175.88	123.23	276.77	72.35
F	F-2	24°15'08.0"	3°24'45"	175.88	52.33	438.60	376.69
F	F-3	77°42'23.6"	8°01'59"	713.25	176.65	346.36	21.55
F	F-4	30°18'44.4"	76°23'40"	75.00	131.61	157.92	76.48

IDENT	CURVE NO.	A	D	Ls	Ts	Lc	Pc	θs	Eθ	
I-95	10	847.34	12.17	3°00'00"	850.00	178.98	144.07	145.92	16°15'00"	322.90

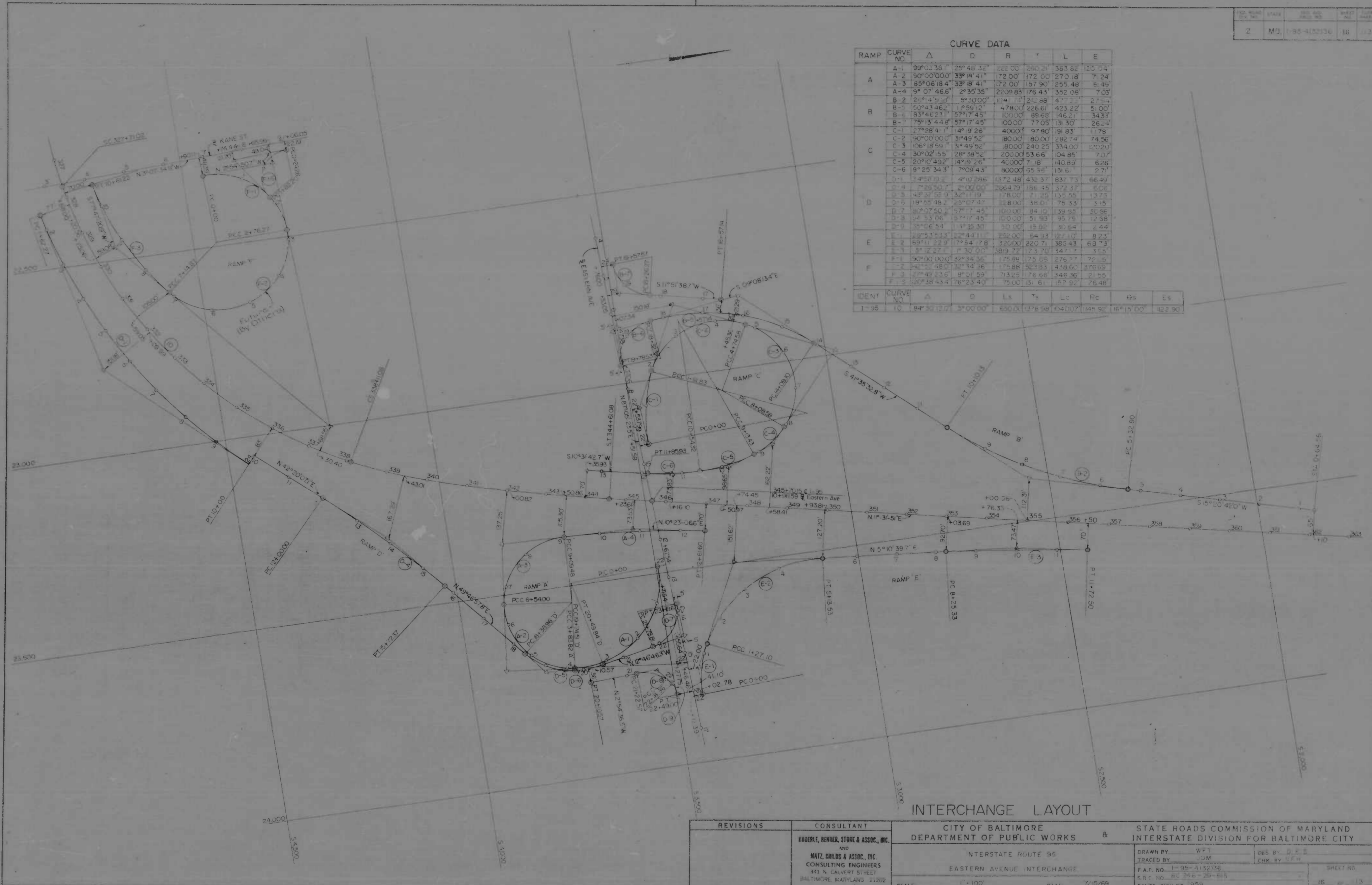

INTERCHANGE LAYOUT

REVISIONS	CONSULTANT KROEMER, BENNETT, STONE & ASSOC., INC. AND MATZ, CHILDS & ASSOC., INC. CONSULTING ENGINEERS 341 N. CALVERT STREET BALTIMORE, MARYLAND 21202	CITY OF BALTIMORE DEPARTMENT OF PUBLIC WORKS & STATE ROADS COMMISSION OF MARYLAND INTERSTATE DIVISION FOR BALTIMORE CITY	INTERSTATE ROUTE 95 EASTERN AVENUE INTERCHANGE
		DRAWN BY: WFT TRACED BY: JDM F.A.P. NO. 1-95-4132136 S.R.C. NO. BE 246-25-M45 BALD. CITY NO. 1952	DES. BY: D.E.S. CHK. BY: JFH SHEET NO. 16 OF 13
		SCALE: 1"=100'	DATE: 7/15/69

REFERENCES





2	MD.	98-403038	17	113
---	-----	-----------	----	-----

1		2		3		4		5		6		7		8		9		10	
11		12		13		14		15		16		17		18		19		20	
21		22		23		24		25		26		27		28		29		30	
31		32		33		34		35		36		37		38		39		40	
41		42		43		44		45		46		47		48		49		50	
51		52		53		54		55		56		57		58		59		60	

REVISIONS	CONSULTANT	CITY OF BALTIMORE DEPARTMENT OF PUBLIC WORKS	STATE ROADS COMMISSION OF MARYLAND INTERSTATE DIVISION FOR BALTIMORE CITY
	KNORLE, BEMBER, STONE & ASSOC., INC. MATZ, CHILDS & ASSOC., INC. CONSULTING ENGINEERS 341 N. FAYETTE STREET BALTIMORE, MARYLAND 21202	INTERSTATE ROUTE 95 EASTERN AVENUE INTERCHANGE	DRAWN BY: R.F.D. CHECKED BY: J.P.V. DATE: 4/20/70
		SCALE: NONE	SHEET NO. 17 OF 113

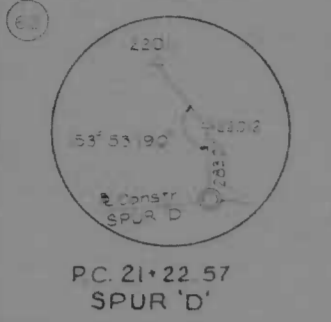
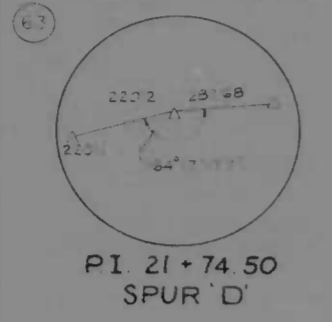
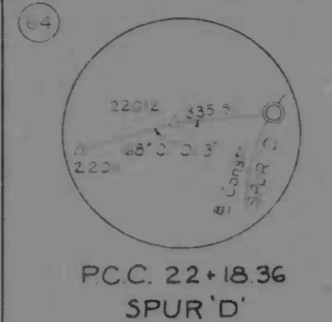
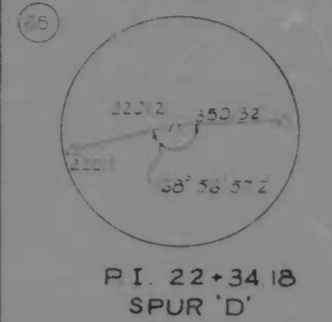
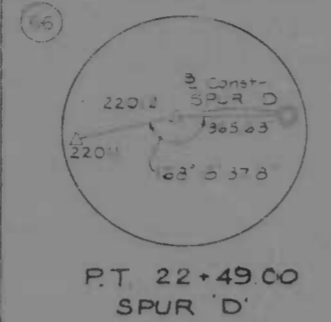
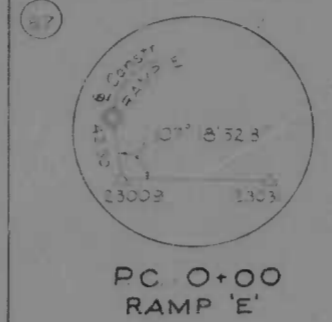
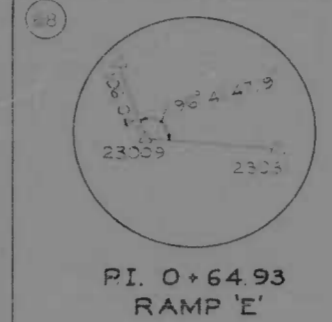
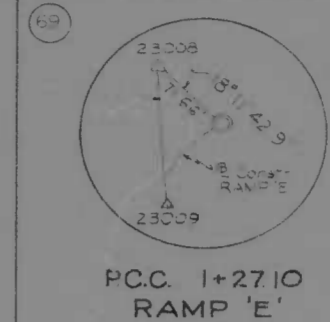
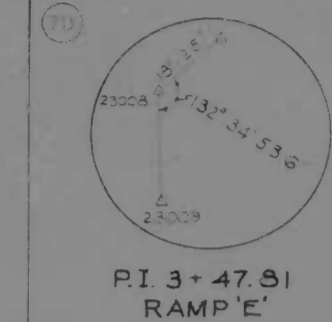
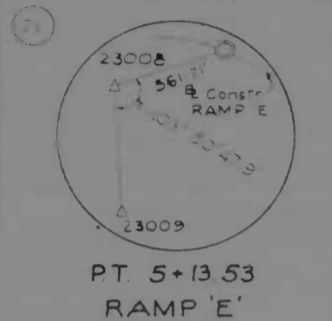
REFERENCES

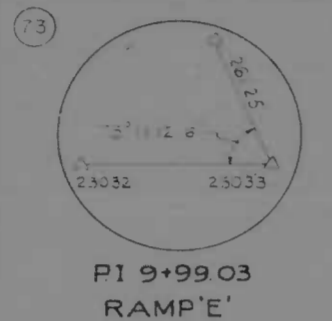
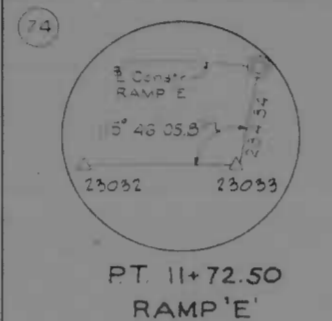
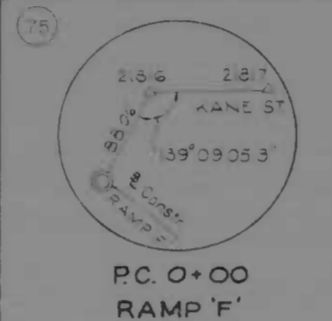
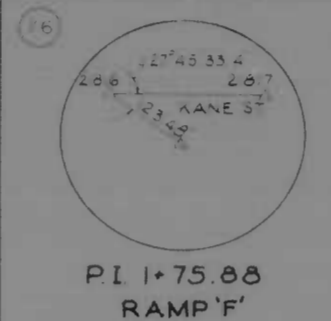
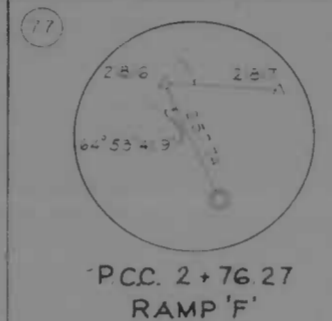
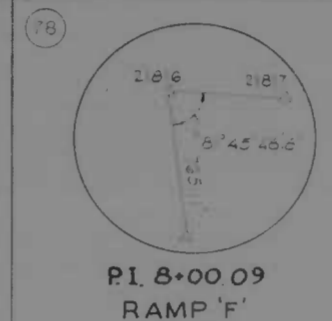
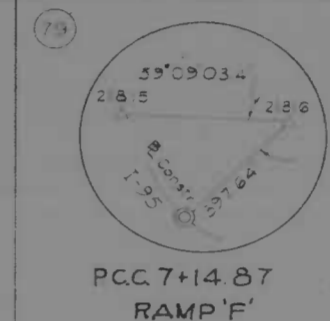
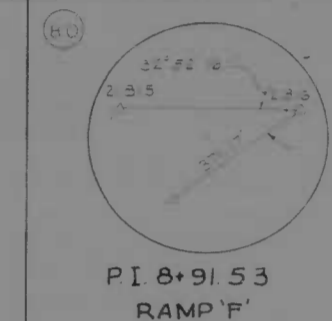
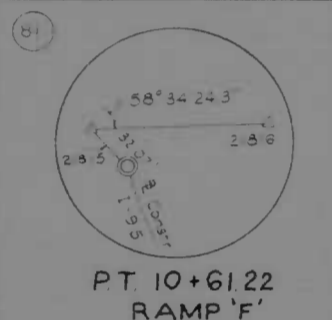
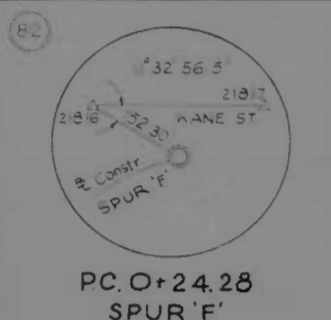
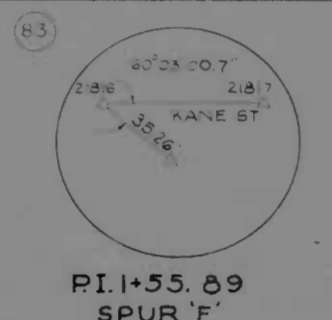
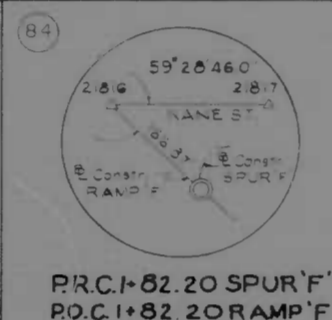
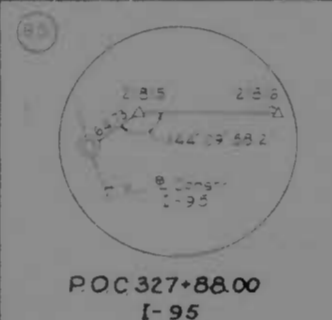
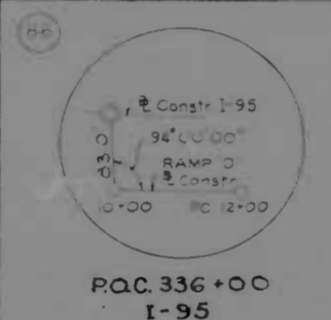
ST. ROAD	STATE	REF. NO.	SHEET NO.	TOTAL SHEETS
2	MD.	195-4132136	18	115

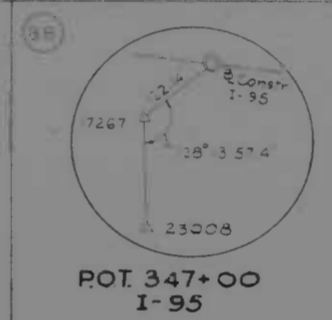
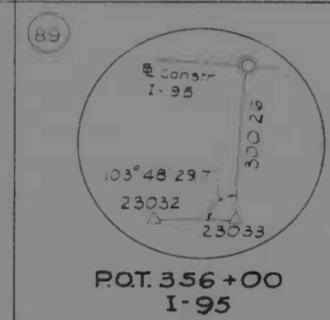
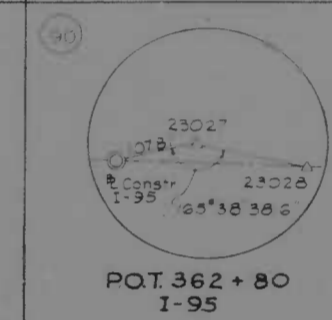
 <p>PT 20+10.57 SPUR 'D'</p>	 <p>PC 21+22.57 SPUR 'D'</p>	 <p>PI 21+74.50 SPUR 'D'</p>	 <p>PCC 22+18.36 SPUR 'D'</p>	 <p>PI 22+34.18 SPUR 'D'</p>	 <p>PT 22+49.00 SPUR 'D'</p>	 <p>PC 0+00 RAMP 'E'</p>	 <p>PI 0+64.93 RAMP 'E'</p>	 <p>PCC 1+27.10 RAMP 'E'</p>	 <p>PI 3+47.81 RAMP 'E'</p>
 <p>PT 5+13.53 RAMP 'E'</p>	 <p>PC 8+25.33 RAMP 'E'</p>	 <p>PI 9+99.03 RAMP 'E'</p>	 <p>PT 11+72.50 RAMP 'E'</p>	 <p>PC 0+00 RAMP 'F'</p>	 <p>PI 1+75.88 RAMP 'F'</p>	 <p>PCC 2+76.27 RAMP 'F'</p>	 <p>PI 8+00.09 RAMP 'F'</p>	 <p>PCC 7+14.87 RAMP 'F'</p>	 <p>PI 8+91.53 RAMP 'F'</p>
 <p>PT 10+61.22 RAMP 'F'</p>	 <p>PC 0+24.28 SPUR 'F'</p>	 <p>PI 1+55.89 SPUR 'F'</p>	 <p>PRC 1+82.20 SPUR 'F' PCC 1+82.20 RAMP 'F'</p>	 <p>POC 327+88.00 I-95</p>	 <p>POC 336+00 I-95</p>	 <p>POS 344+00 I-95</p>	 <p>POT 347+00 I-95</p>	 <p>POT 356+00 I-95</p>	 <p>POT 362+80 I-95</p>

REVISIONS	CONSULTANT	CITY OF BALTIMORE DEPARTMENT OF PUBLIC WORKS	STATE ROADS COMMISSION OF MARYLAND INTERSTATE DIVISION FOR BALTIMORE CITY
	KNOX, BENDER, STONE & ASSOC., INC. WATZ, CHILDS & ASSOC., INC. CONSULTING ENGINEERS 341 N. CALVERT STREET BALTIMORE, MARYLAND 21202	INTERSTATE ROUTE 95 EASTERN AVENUE INTERCHANGE SCALE: None	DRAWN BY: R.F.D. TRACED BY: L.L.M. F.A.P. NO. 195-4132136 S.R.C. NO. DC 2416-25-815 BALTO. CITY NO. 1959
		DATE: 4-20-70	DES. BY: D.E.S. CHK. BY: J.P.H. SHEET NO. 18 OF 115

CONTROL COORDINATES

NO. SHEET	DATE	JOB NO.	SHEET NO.	TOTAL SHEETS
2	MD. 1-95-4132-36	19	112	

POINT NUMBER	LOCATION	NORTH COORDINATE	EAST COORDINATE	BEARING
1	S.O. 327+71.02	4790.0612	22289.2965	N79°47'03.0"E
2	P.I. 335+29.96	4790.9291	22839.3791	N27°46'50.9"E
3	C.S. 338+11.09	-4206.4127	23009.8968	N27°46'50.9"E
4	P.I. 342+29.42	-4013.2385	23201.6630	N11°31'00.9"E
5	S.T. 344+61.08	3586.8489	23285.6920	N11°31'01.0"E
6	T.S. 373+42.36	773.5269	23362.8062	
7	P.C. 1-4+00	3615.4473	22812.7489	N87°05'23.5"E
8	P.O.T. 10+38.59 P.O.T. 345+70.15 (1-95)	-3479.9794	23310.4548	N87°05'23.5"E
9	P.O.T. 17+00	-3449.4505	23911.0018	
10	P.C. 0+00	-3493.3735	23480.3034	N87°05'23.5"E
11	P.I. 2+00.21	-3480.1623	23740.1749	S 87°09'01.8"W
12	P.C.C. 3+83.82	3738.8717	23712.2570	S 87°09'01.8"W
13	P.I. 5+55.82	-3205.8817	23693.8694	N83°50'53.4"E
14	P.C.C. 6+54.00	3891.4541	23622.8594	N83°50'58.4"W
15	P.I. 8+11.90	-3974.5372	23388.8688	N 1°18'20.0"E
16	P.C.C. 9+09.48	-3716.6757	23369.3283	N 1°15'20.0"E
17	P.I. 10+85.91	3540.2853	23373.1938	N10°23'06.6"E
18	P.T. 12+61.60	-3366.7432	23404.9680	
19	STA. 0+04.56	1860.2338	23574.5647	S15°20'42.0"W
20	P.C. 5+32.96	-2311.8774	23490.6777	S15°20'42.0"W
21	P.I. 7+75.78	-2846.0917	23386.3585	S41°35'32.8"W
22	P.T. 10+10.13	-2727.7271	23425.1392	S41°35'32.8"W
23	P.C. 14+09.16	-3026.1219	22960.2795	S41°35'32.8"W
24	P.I. 16+45.71	-3195.5008	22809.8488	S 9°08'13.4"E
25	P.C.C. 18+32.32	-3419.3363	22840.8326	S 9°08'13.4"E
26	P.I. 19+22.00	-3507.8808	22860.0748	N87°05'23.5"E
27	P.T. 19+78.53	-3503.5277	22949.6417	
28	P.T. 16+57.14	3237.7876	22814.7424	S11°51'38.7"W
29	P.C. 18+28.27	-3403.3079	22779.9802	S11°51'38.7"W
30	P.I. 19+03.32	-3478.7136	22764.1437	S87°05'23.5"W
31	P.T. 19+87.57	-3482.6255	22687.1922	
32	P.C. 0+00	-3455.4709	23162.5272	S87°05'23.5"W
33	P.I. 0+97.80	-3470.4361	23064.3651	N65°25'55.4"W
34	P.C.C. 1+91.83	-3429.7743	32975.9106	N65°25'55.4"W
35	P.I. 2+73.53	-3354.9354	22812.2062	N24°34'04.6"E
36	P.C.C. 4+74.98	-3191.2310	22987.0452	N24°34'04.6"E
37	P.I. 7+14.83	-2972.7452	22986.9385	S49°06'56.3"E
38	P.C.C. 9+08.58	-3125.9842	23188.5658	S49°06'56.3"E
39	P.I. 8+62.24	-3185.1067	23209.1347	S19°04'40.8"E
40	P.C.C. 9+73.43	3216.8496	23228.6737	S19°04'40.8"E
41	P.T. 9+94.61	-3281.0802	23249.9394	

POINT NUMBER	LOCATION	NORTH COORDINATE	EAST COORDINATE	BEARING
41	P.T. 9+94.61	3282.0900	23249.9394	
42	P.C.C. 10+54.32	-3354.2572	23249.9700	S01°06'08.4"E
43	P.I. 11+22.28	3470.0030	23247.8011	S01°06'08.4"E
44	P.T. 11+85.33	-3485.0465	23236.2492	S10°31'42.7"E
45	P.O.T. 13+35.93	-3632.5212	23207.8404	S10°31'42.7"E
46	P.C. 1+02.27	-4865.3490	22394.7673	
47	P.I. 5+94.64	-4770.8393	22776.5735	N77°18'26.3"E
48	P.T. 10+00.00	-4450.7218	23067.7617	N42°20'07.1"E
49	P.O.T. 10+00.00 (24" x P.T. 10+00)	-4434.8573	23060.0207	N42°20'07.1"E
50	P.I. 12+00.00	-4286.7135	23194.7238	N42°20'07.1"E
51	P.I. 13+86.45	-4148.8873	23310.2804	N49°46'57.8"E
52	P.T. 18+72.37	-4328.4963	23452.6522	N49°46'57.8"E
53	P.C. 18+28.96	-3956.3647	23656.2399	N49°46'57.8"E
54	P.I. 19+10.21	-3810.3573	23710.6286	N 6°09' 1.9"E
55	P.C.C. 19+74.51	-3729.5145	23718.2624	N 6°09' 1.9"E
56	P.T. 20+12.02	-3701.7205	23722.3348	N12°46'48.3"E
57	P.T. 20+49.84	-3864.6332	23723.3259	N12°46'48.3"E
58	P.C. 21+78.81	-3538.8790	23635.3988	N12°46'48.3"E
59	P.I. 22+62.01	-3456.8581	23646.7949	S87°05'23.5"W
60	P.T. 23+18.67	-3461.1281	23592.7990	
61	P.T. 20+10.57	-3701.6827	23756.2343	N 2°54'38.5"W
62	P.C. 21+22.37	-3589.8282	23749.5481	N 2°54'38.5"W
63	P.I. 21+74.50	-3637.9652	23746.9116	N 2°54'38.5"W
64	P.C.C. 22+18.36	-3508.9759	23787.9190	N51°58'29.5"E
65	P.I. 22+34.18	-3496.2307	23800.2811	N87°05'23.5"E
66	P.T. 22+49.00	-3495.4275	23816.0807	
67	P.C. 0+00	-3431.9734	23821.8660	S87°05'23.5"W
68	P.I. 0+84.93	-3435.2648	23786.6173	N84°00'43.2"E
69	P.C.C. 1+27.10	-3406.8178	23898.2925	N84°00'43.2"E
70	P.I. 3+47.81	-3310.1064	23499.8565	N 6°10'39.7"E
71	P.T. 5+13.83	-3090.2961	23516.7729	N 6°10'39.7"E
72	P.C. 8+28.33	-2779.7894	22647.9234	N 5°10'39.7"E
73	P.I. 9+69.03	-2606.7743	22563.5898	N13°23'06.8"E
74	P.T. 11+42.50	-2450.9160	22594.8992	
75	P.C. 0+00	-4451.4996	22311.7018	N 2°54'30.7"W
76	P.T. 1+75.88	-4375.8475	22302.7601	N87°05'09.3"E
77	P.C.C. 2+76.27	-4268.9060	22478.4122	

POINT NUMBER	LOCATION	NORTH COORDINATE	EAST COORDINATE	BEARING
78	P.C.C. 2+76.27	-4268.9060	22478.4122	
79	P.I. 3+00.09	-4240.2750	22301.5098	N87°05'09.3"E
80	P.C.C. 7+14.87	-4877.2224	22830.4878	S49°57'57.3"E
81	P.I. 8+91.53	-4690.8604	22465.2220	S49°57'57.3"E
82	P.T. 10+61.22	-4728.7267	22292.5947	S77°47'20.8"W
83	P.C. 0+24.28	-4237.7102	22273.7632	S 2°54'30.7"E
84	P.I. 1+58.80	-4368.7501	22280.4545	N56°25'25.9"E
85	P.O.C. 1+52.20 (Spur F) P.O.C. 1+52.20 (Main F)	-4298.9963	22390.1264	
86	P.O.C. 327+88	-4796.9254	22338.9493	
87	P.O.T. 326+00	-4583.0758	22484.9158	
88	P.O.T. 344+00	-2548.6856	23276.3924	
89	P.O.T. 347+00	-3382.7905	23336.4108	
90	P.O.T. 356+00	-2470.9146	23516.3170	
91	P.O.T. 362+80	-1804.6425	23687.2453	

BALTIMORE CITY MONUMENTS

DESIGNATION	NORTH COORDINATE	EAST COORDINATE
17257	-3444.634	23416.660
21541	-380.872	23779.756
71543	-364.044	24174.221
21811	-3484.304	23645.470
21786	-4779.080	21718.089
21768	-4731.207	22935.273
21789	-4715.941	22613.561
21814	-4955.202	22282.475
21815	-4746.086	22265.918
21816	-4387.872	22250.674
21817	-4088.366	22235.724
21818	-3829.863	22229.051
22011	-3729.870	23227.911
22012	-3602.557	23466.809
22021	-3084.220	23365.726
22022	-2719.222	23488.379
22024	-2561.501	23535.864
22725	-2090.202	23574.189
23008	-3434.155	23632.006
23009	-3417.212	23361.110
23027	-1696.824	23663.077
23028	-1306.671	23150.884
23029	-1126.333	23033.900
23030	-892.051	22918.359
23031	-874.997	23843.829
23032	-2821.285	23829.323
23033	-2524.919	23811.638
23034	-2186.535	23804.208

REVISIONS	CONSULTANT	CITY OF BALTIMORE DEPARTMENT OF PUBLIC WORKS		STATE ROADS COMMISSION OF MARYLAND INTERSTATE DIVISION FOR BALTIMORE CITY	
	KWOERLE, BENDER, STONE & ASSOC., INC. WATZ, DIVERS & ASSOC., INC. CONSULTING ENGINEERS 381 N. CALVERT STREET BALTIMORE, MD. 21202	INTERSTATE ROUTE 95 EASTERN AVENUE INTERCHANGE		DRAWN BY: J.C.B. TRACED BY: R.K. F.A.W. NO. 11-56-91321-6 S.E.C. NO. BC 345-28-2-8 BALTO. CITY NO. 1955	CHK. BY: J.E.H. SHEET NO. 19 OF 112
		SCALE: NONE	DATE: 10-8-59		

JOB NO.	STATE	SECTION	SHEET NO.	TOTAL SHEETS
2	MD.	1-95-R-2213E	2	113

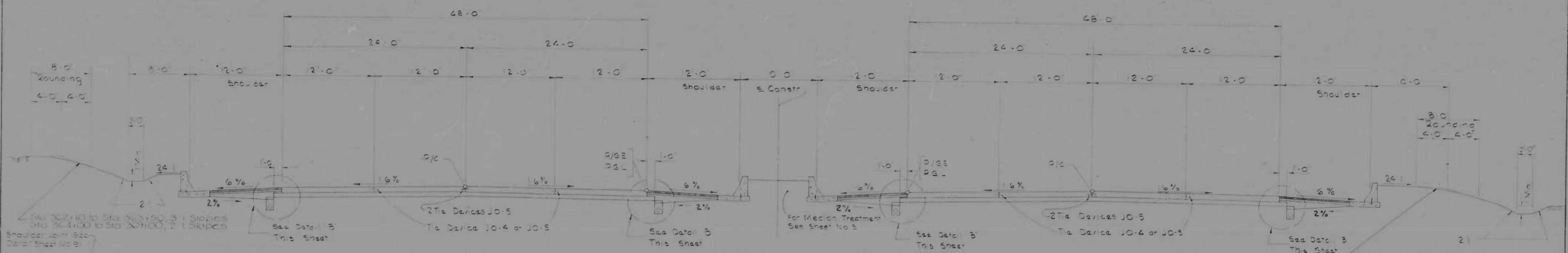

INTERSTATE ROUTE 95

3 (Nominal) Bituminous Concrete Shoulders
Spec. B Using Bond PC-1-G (Stone or Slag)
Bituminous Material For Prime Coat
7 Stabilized Shoulders Dense Graded Stabilized Aggregate

8 Continuous Reinforced Cement Concrete Pavement, C.P.
7 Sub-base Using Crusher Run, CR-6
Limit of Class 1 Excavation And Top of Subgrade

DETAIL - L
Scale: 1/2" = 1'-0"

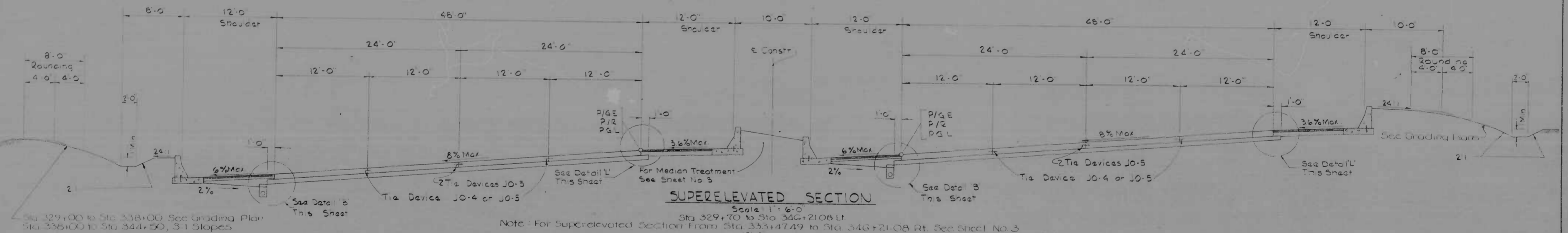

8 Continuous Reinforced Cement Concrete Pavement, C.P.
7 Subbase Using Crusher Run, CR-6
Limit of Class 1 Excavation And Top of Subgrade

DETAIL - B
8 RIGID PAVEMENT
Scale: 1/2" = 1'-0"

* Cost of No. 6 Aggregate to be included in Contract Unit Price For 6" Perforated Circular Pipe Longitudinal Underdrain.

9 (Nominal) Bituminous Concrete Shoulders
Spec. B Bond PC-1-G (Stone or Slag)
Bituminous Material For Prime Coat
3 Stabilized Shoulders Dense Graded Stabilized Aggregate Base
4 Stabilized Shoulders Dense Graded Stabilized Aggregate Base
Stabilized Shoulders Dense Graded Stabilized Aggregate Base
Limit of Class 1 Excavation And Top of Subgrade
6 Perforated Circular Pipe Longitudinal Underdrain (See Sta. P1 UD 3)

REVISIONS	CONSULTANT	CITY OF BALTIMORE DEPARTMENT OF PUBLIC WORKS	STATE ROADS COMMISSION OF MARYLAND INTERSTATE DIVISION FOR BALTIMORE CITY
	KNOERLE, BENDER, STONE & ASSOC., INC. 1100 WATZ, DREHRS & ASSOC., INC. CONSULTING ENGINEERS 341 N. CALVERT STREET BALTIMORE, MARYLAND 21202	INTERSTATE ROUTE 95 EASTERN AVENUE INTERCHANGE	DRAWN BY: A.C.B. TRACED BY: A.C.B. F.A.P. NO. 1-95-4(3)136 S.R.C. NO. BC 445-29-015 BALTO. CITY NO. 1559
		DATE: 4-20-70	DES. BY: D.E.S. CHK. BY: V.F.H. SHEET NO. 2 of 113

SUPERELEVATION TABLE

PROJECT NO.	MD I-95-4(3)136
SHEET NO.	20

INTERSTATE ROUTE 95 S B R														INTERSTATE ROUTE 95 N B R														
SUPER RATE	REMARKS	EDGE SHOULDER		END LANE 5		END LANE 4		EDGE LANE 3		P.G. EDGE LANE 1		EDGE SHOULDER		STATION	EDGE SHOULDER		P.G. EDGE LANE 1		EDGE LANE 3		END LANE 4		END LANE 5		REMARKS	SUPER		
		ELEV	DIST LT	ELEV	DIST LT	ELEV	DIST LT	ELEV	DIST LT	ELEV	DIST LT	ELEV	DIST LT		ELEV	DIST RT	ELEV	DIST RT	ELEV	DIST RT	ELEV	DIST RT	ELEV	DIST RT			ELEV	DIST RT
0.000	Rev. Spiral Level													1 S 321+21.02	5.58	17	41	85	77	88.42							Rev. Spiral Level	0.000
	Plane Inclined													322+51.02	5.58	17	41	85	77	88.42							Plane Inclined	
	Shoulder Level													324+78.52	5.58	17	41	85	77	88.42							Shoulder Level	
0.080	Full Superelevation	74.30	96.08	74.99	84.66	76.56	65	78.48	41	80.40	17	80.81	5.58	S.C. 327+71.02	5.58	17	80.40	41	82.32	65	84.24	77	85.20	88.42	85.61	Full Superelevation	0.080	
0.080	Full Superelevation	53.78	84.64	54.47	73.22	55.13	65	57.05	41	58.97	17	59.38	5.58	C.S. 338+11.06	5.58	17	58.97	41	60.89	65	62.81	77	63.76	66.42	63.22	Full Superelevation	0.080	
	Shoulder Level	54.15	80.49	54.85	79.07	55.47	65	56.53	41	57.59	17	57.99	5.58	341+03.58	5.58	17	57.59	41	58.65	65	59.71	77	60.67	61.52	59.71	Shoulder Level		
	Plane Inclined	55.45	95.04	57.04	83.62	57.34	65	57.72	41	58.10	17	57.78	5.58	343+31.08	5.58	17	58.10	41	58.48	65	58.86	77	59.24	60.09	58.86	Plane Inclined		
	Half Level					58.62	65	59.00	41	59.00	17	58.50	5.58	S.T. 344+61.08	5.58	17	59.00	41	59.38	65	59.38	77	58.88	58.88	59.38	Half Level		
0.016	Tangent Runout					60.74	65	61.12	41	60.74	17	60.06	5.58	346+21.08	5.58	17	60.74	41	61.12	65	60.74					Tangent Runout	0.016	
0.016	Tangent Runout	107.04	76.42			107.73	65	108.11	41	107.73	17	107.04	5.58	371+72.36	5.58	17	107.73	41	108.11	65	107.73					Tangent Runout	0.016	
	Half Level	106.81	76.42			107.50	65	107.88	41	107.50	17	107.38	5.58	T.S. 373+32.36	5.58	17	107.88	41	108.26	65	108.26					Half Level		
	Pl. Incl. & Full Super	106.04	76.42			106.73	65	107.11	41	107.49	17	107.17	5.58	374+55.44	5.58	17	107.49	41	107.87	65	108.25					Pl. Incl. & Full Super		
	Full Superelevation	105.56	76.42			106.25	65	106.63	41	107.01	17	106.69	5.58	S.C. 378+52.36	5.58	17	107.31	41	107.69	65	107.77					Full Super	0.016	

STATION	24' LT	PROFILE GRADE ELEV	24' RT	REMARKS
5+76.00	75.03	75.94		Exist. Edge Lt. Begin Transition
7+06.00	75.57	75.93	76.17	Exist. Edge Rt. Begin Transition
7+92.12	76.97	76.97	76.97	P.R.C. Level
9+18.79	81.66	80.22	78.78	End Transition Begin Full Super 6%
9+85.58	83.50	82.06	80.62	End Full Super 6% Begin Transition
10+88.00	85.08	84.89		Track Lt. End Transition
10+94.00	85.08	85.05		Track Lt. Begin Transition
11+12.25	85.58	85.56	85.54	P.T.
11+14.00		85.61	85.61	Track Rt. End Transition
11+20.00		85.77	85.61	Track Rt. Begin Transition
11+80.34	87.44	87.44	87.06	Half Level
12+48.44	89.85	89.32	88.55	P.C.
13+63.04	94.11	92.67	91.27	End Transition Begin Full Super 6%
				End Full Super 6% Begin Transition
14+78.45	96.45	96.45	96.45	P.R.C. Level
15+46.5	98.76	98.79	97.92	Exist. Edge Rt. End Transition
16+36.00	102.56	102.14		Exist. Edge Lt. End Transition

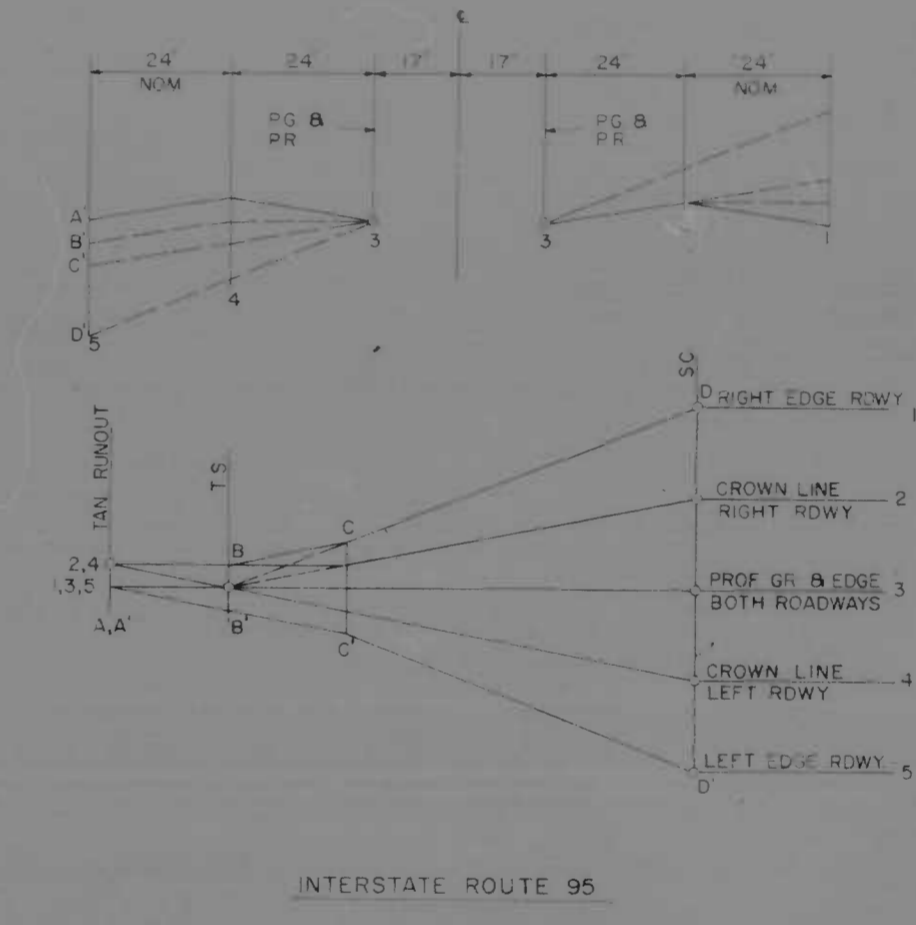
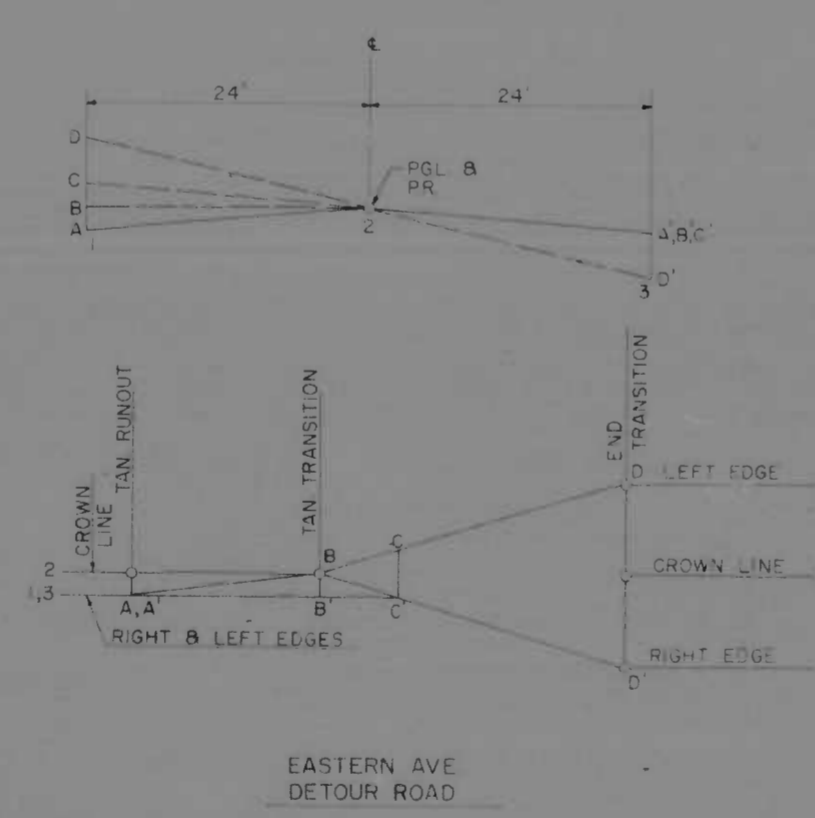

METHOD OF ATTAINING SUPERELEVATION

REVISIONS	CONSULTANT	CITY OF BALTIMORE DEPARTMENT OF PUBLIC WORKS	STATE ROADS COMMISSION OF MARYLAND INTERSTATE DIVISION FOR BALTIMORE CITY
	ENGERLE, BENDER, STONE & ASSOC., INC. AND MATZ DUBOS & ASSOC., INC. CONSULTING ENGINEERS BALTIMORE, MARYLAND 21202	INTERSTATE ROUTE 95 EASTERN AVENUE INTERCHANGE	DRAWN BY: J.H.R. TRACED BY: J.H.R. F.A.P. NO. I-95-4(3)136 S.R.C. NO. DC 245-25-812 BALTO. CITY NO. 1959
		SCALE: NONE	DATE: 4-20-70
			SHEET NO. 20 OF 23

SUPERELEVATION TABLE

2 MD 1-95-4132156 24 115

RAMP "A"					
STATION	PROFILE GRADE	SLOPE (%)	DIST. FT.	ELEV. FT.	REMARKS
P.C.	0+00	0.040	0.00	92.80	Begin Transition
	0+50.40	-0.0647	22.00	94.03	End & Begin Transition
	1+57.00	-0.090	22.00	94.55	End Transition
	3+66.00	-0.090	22.00	86.09	Begin Transition
P.C.C.	3+83.82	0.0994	22.00	84.74	
	3+96.00	0.10	22.00	83.82	End Transition - Begin Full Super
P.C.C.	6+54.00	-0.10	22.00	88.16	
	8+36.00	-0.10	22.00	87.87	End Full Super - Begin Transition
P.C.C.	9+09.48	-0.08014	22.00	86.62	
	10+21.00	-0.05	16.50	87.45	End Transition
	11+95.00	-0.05	16.50	89.57	Begin Transition
	22+62.80	-0.03871	15.00	61.07	+ 347+00.00 (70' Rt.)
(E. 95)	247+00.00	0.03871	65.00	61.07	
(E. 95)	248+34.00	-0.016	82.32	63.75	End Transition

RAMP "B"					
STATION	PROFILE GRADE	SLOPE (%)	DIST. FT.	ELEV. FT.	REMARKS
	0+64.36	-0.0160	15.22	91.84	302+10 65' Lt.
	4+25.00	-0.0160	15.00	92.56	Begin Transition
P.C.	5+32.90	-0.04864	15.00	79.45	
	5+88.00	-0.065	15.40	79.23	End Transition
	8+17.75	-0.065	24.41	79.18	Begin Transition
P.T.	10+10.13	-0.03454	36.00	71.61	
	12+26.28	+0.00	36.00	72.67	End & Begin Transition
P.C.	14+09.10	+0.03567	36.00	72.18	
	14+99.51	+0.0530	36.00	71.93	End Transition
	16+57.14	+0.0550	36.00	71.76	Begin Transition
	17+71.14	+0.0150	22.00	72.42	End & Begin Transition
P.C.C.	18+32.32	+0.01785	22.00	74.58	
	18+78.51	+0.020	22.00	76.40	End Transition

RAMP "B" S.P.U.R.					
STATION	PROFILE GRADE	SLOPE (%)	DIST. FT.	ELEV. FT.	REMARKS
P.T.	16+57.14	0.055	24.00	70.44	Begin Transition
	17+75.24	-0.015	28.15	72.42	End & Begin Transition
P.C.	18+26.27	+0.00	30.00	74.08	End & Begin Transition
	18+88.25	+0.0163	30.00	76.25	End Transition
P.T.	19+57.57				

RAMP "D"					
STATION	PROFILE GRADE	SLOPE (%)	DIST. FT.	ELEV. FT.	REMARKS
P.C.	0+00.00	-0.03		80.50	Begin Transition
	1+25.72	-0.0628	22.00	76.04	End & Begin Transition
	1+82.20	-0.04	22.00	73.82	End & Begin Transition
P.C.C.	1+91.85	-0.0433	22.00	75.55	
	2+42.47	0.10	22.00	71.77	End Transition - Begin Full Super
P.C.C.	8+08.58	-0.10	22.00	60.95	
P.C.C.	9+13.43	-0.10	22.00	59.91	
P.C.C.	10+54.22	0.10	18.65	58.83	
	10+78.79	0.10	17.51	58.70	End Full Super - Begin Transition
P.C.C.	11+85.93	-0.065	15.00	58.40	
	12+35.93	-0.018	15.00	57.64	End Transition

RAMP "D" S.P.U.R.					
STATION	PROFILE GRADE	SLOPE (%)	DIST. FT.	ELEV. FT.	REMARKS
P.T.	7+25.80	-0.0400	24.00 Lt.	69.82	Begin Transition
	10+00.00	0.01978	24.00 Lt.	66.14	
	10+00.00	0.01928	24.00 Rt.	66.60	
	10+87.10	+0.00	24.00	64.74	End Transition
P.C.	12+00.00	-0.0250	24.00	63.52	
	15+27.02	-0.0250	12.00	70.86	
P.T.	15+72.37	-0.0250	12.00	72.87	
	15+75.40	-0.0250	12.00	73.01	
	16+23.79	+0.00	12.00	75.78	
P.C.	18+38.96	+0.0790	12.00	89.85	
	19+06.78	+0.0790	12.00	92.24	
P.C.C.	19+74.51	+0.0790	12.00	94.99	
	20+10.57	+0.0560	12.00	98.91	
P.T.	20+49.84	+0.0357	12.00	96.91	
	21+12.44	+0.050	20.84	97.76	
P.C.	21+78.81	+0.0248	22.00	99.20	
	22+29.74	+0.0400	0.00	99.40	

RAMP "B" S.P.U.R.					
STATION	PROFILE GRADE	SLOPE (%)	DIST. FT.	ELEV. FT.	REMARKS
P.T.	20+10.57	-0.0464	24.00	95.91	Begin Transition
	22+10.33	+0.0100	30.00	103.10	End Transition
	22+49.00		0.00	104.71	

RAMP "C"					
STATION	PROFILE GRADE	SLOPE (%)	DIST. FT.	ELEV. FT.	REMARKS
P.C.	0+00.00			105.36	
	0+36.89	0.0400		103.61	Begin Transition
P.C.C.	1+27.10	-0.0670	22.00	98.96	End & Begin Transition
	2+37.10	-0.0900	22.00	92.38	End Transition
	4+33.00	-0.0900	22.00	79.20	Begin Transition
P.T.	5+12.53	-0.0692	22.00	75.59	
	7+19.00	-0.0160	17.39	71.49	End & Begin Transition
P.C.	8+29.33	-0.0286	15.00	73.43	
	8+75.00	-0.0350	15.00	72.11	End Transition
	11+05.83	-0.0350	15.00	77.28	Begin Transition
P.T.	11+72.90	-0.0287	15.00	76.94	+ 354+50 (70' Rt.)
	12+50.00	-0.0287	85.00	78.94	
	13+83.33	-0.0180	82.33	82.09	End Transition

RAMP "E"					
STATION	PROFILE GRADE	SLOPE (%)	DIST. FT.	ELEV. FT.	REMARKS
P.C.	0+00.00	-0.0568	24.33	62.87	Begin Transition
	1+30.79	-0.10	22.00	66.01	End Transition - Begin Full Super
P.C.C.	2+76.27	-0.10	22.00	69.71	
	6+81.86	-0.10	22.00	63.38	End Full Super - Begin Transition
P.C.C.	7+14.87	-0.092	22.00	64.12	
	7+64.68	-0.080	19.48	68.62	End Transition
P.T.	10+61.22	-0.080	15.00	74.51	+ 327+56 (70' Lt.)

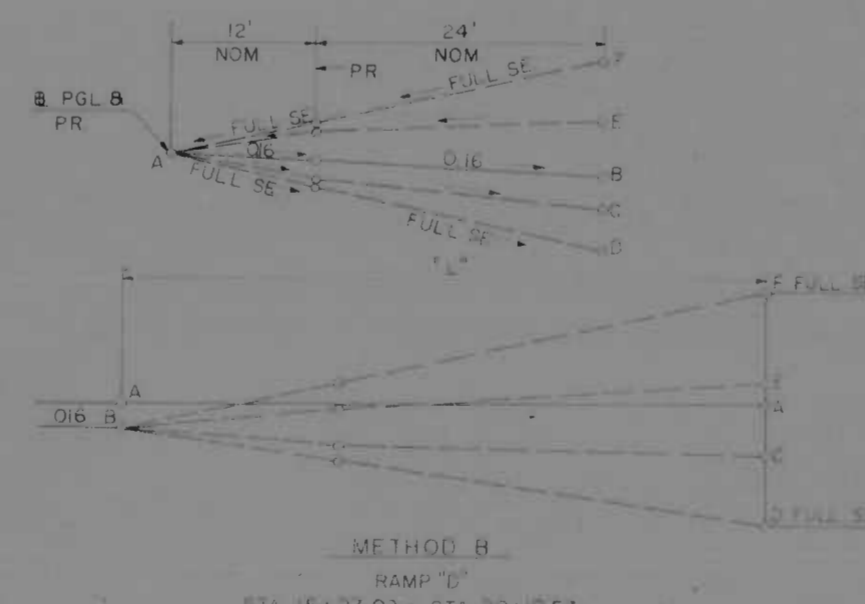
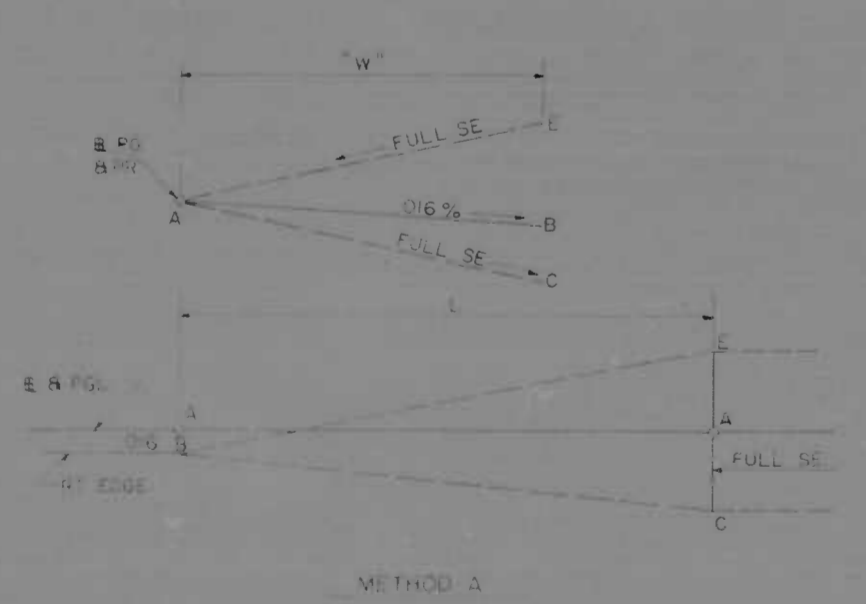

METHOD OF ATTAINING SUPERELEVATION

REVISIONS	CONSULTANT	CITY OF BALTIMORE	STATE ROADS COMMISSION OF MARYLAND
	KROEHL, BENDER, STONE & ASSOC., INC. MATZ, ORRIS & ASSOC., INC. CONSULTING ENGINEERS 341 N. BALTIMORE STREET BALTIMORE, MARYLAND 21202	DEPARTMENT OF PUBLIC WORKS INTERSTATE ROUTE 95 EASTERN AVENUE INTERCHANGE	INTERSTATE DIVISION FOR BALTIMORE CITY DRAWN BY: JPK CHECKED BY: JPK DATE: 1-25-70 S.R.C. NO. BC 245-23-815 BALTIMORE, MD 21202

SHEET NO.	STATE	FILE NO.	SHEET NO.	TOTAL SHEETS
2	MD.	1-95-A132156	22	113

SOIL LEGEND

	A-5, SWAMP MUCK		A-4-7, CLAYEY SILT
	A-3, SAND, NON-PLASTIC		A-5, SILT WITH MICA AND/OR DECOMPOSED ROCK
	A-2, SAND & FINES		A-7, CLAY
	A-2-4, SILTY SAND		A-7-2, SANDY CLAY
	A-2-7, CLAYEY SAND		A-7-4, SILTY CLAY
	A-4, SILT		A-6, COLLOIDAL CLAY
	A-4-2, SANDY SILT		

PLAN LOCATION OF SOIL BORINGS
 PLAN LOCATION OF GOW BORINGS
 GENERAL LOCATION OF REQUIRED MATERIAL REMOVAL
 IN-PLACE DRY DENSITY (DEPTH)
 R.C.F. % MOISTURE (DATE)
 PROFILE VERTICAL SCALE (1"=10')

LL - LIQUID LIMIT PL - PLASTICITY INDEX NP - NON PLASTIC
 M.D.D. & O.M.C. - MAXIMUM DRY DENSITY AND OPTIMUM MOISTURE CONTENT AS DETERMINED BY A.S.H.T.O. DESIGNATION T-99 METHOD "C"
 UNLESS OTHERWISE NOTED ON PLANS ALL SOIL SURVEY BORINGS FOR ROADWAY CONSTRUCTION WERE LEFT OPEN FOR 24 HOURS WITH NO EXCESS MOISTURE OR FREE WATER ENCOUNTERED DURING TIME OF SOIL SURVEY (DDA 8 & 1/69-3, 69) BORING DATA FOR STRUCTURES IS INDICATED ON RESPECTIVE PLAN SHEETS

ABBREVIATIONS

- B.C.C.M.P. - Bituminous Coated Corrugated Metal Pipe
- B.M. - Bench Mark
- B.L.S. - Base Line Survey
- C.L.C. - Center Line Construction
- Elev. - Elevation
- P.G.L. - Profile Ground Line
- P.G.L. - Profile Grade Line
- P.C. - Point of Curvature
- P.T. - Point of Tangency
- P.G.E. - Profile Grade Elevation
- R.C.P. - Reinforced Concrete Pipe
- S.S.D. - Stopping Sight Distance
- H.S.D. - Headlight Sight Distance
- S.E. - Super-elevation
- S.D.D. - Surface Drain Depth
- S.D. - Side Ditch
- STD. PL. - Standard Plan
- RE - Remove Existing Facility
- V.C.P. - Vitrified Clay Pipe
- V.C.P.X. - Vitrified Clay Pipe (Extra Strength)
- P.S.F. - Pounds Per Square Foot
- N.T.S. - Not to Scale
- P.S.I. - Pounds Per Square Inch
- G.R.W.B. - Guard Rail w/ Beam Approach Flare
- RE - Remove Existing Facility (See Special Provisions)
- R.C.S.P. - Reinforced Concrete Sewer Pipe

EXPLANATORY NOTES AND REFERENCES

- VERTICAL CONTROL**
The Location and Elevations of Bench Marks are Shown on The Plans. All Elevations Shown are Based on Baltimore City Datum.
- DITCHES**
All Side Ditches on This Project Will be 2' in Width Unless Otherwise Noted on The Plans.
- INVERT ELEVATIONS**
All Invert Elevations are Approximate and May be Modified to Meet Conditions Encountered During Installation of Drainage Structures.
- SIGHT DISTANCE**
Stopping Sight Distance For Crest Vertical Curves is Based on a Height of Object = 0.25 and a Height of Eye = 3.0'. Headlight Sight Distance For Sag Vertical Curves is Based on a Height of Headlight = 2.0' and an upward Divergence of Beam = 1%.
- MATERIALS SALVAGED IN CONSTRUCTION**
These Materials Shall Become The Property of the Contractor and Shall be Removed From The Site of Construction Except For Those Items Provided For Salvage as City Property in The Special Provisions.
- HORIZONTAL CONTROL**
The Project is Directed to Conform with The Baltimore City Grid System.
- SPECIFICATIONS**
Specifications For Materials, Highways, Bridges and Incidental Structures, Dated March 1968 and Revised Thereof or Additions Thereof Included in The Proposal and Special Provisions.
- MAINTENANCE OF TRAFFIC AND UTILITY SERVICE**
Special Attention is Directed to The Requirements For Maintenance of Traffic and Utility Service During The Construction of This Project. See Special Provisions and Plans For Construction Phases Required.
- EXISTING UTILITIES**
Existing Utility Locations Shown on Plans are Approximate. It Shall be The Contractor's Responsibility to Verify The Exact Locations by Test Pits and Other Methods Prior to Commencing Work. The Necessary Relocation and/or Adjustment of The Existing Utilities Will be Performed by Others Unless Otherwise Provided For in The Proposal or Special Provisions.
- CLEARING AND GRUBBING**
Special Attention is Directed to The Fact That no Clearing and Grubbing or Grading May Commence For This Project Until The Clearing Limits are Staked in The Field and Approved by The Engineer.
No Clearing Will be Allowed Beyond Construction Limits.
- FIRE HYDRANT INSTALLATION**
Special Attention is Directed to The Special Provisions Relative to This Item of Work.
In Addition to Contacting All Residents Affected by The Water Shutdown During The Fire Hydrant Installation, the Following Major Industries Should be Given Advance Notification:
ANCHOR FENCE DIVISION - ANCHOR POST PRODUCTS, INC.
Mr. John Gross 633-6500
CONTAINER CORPORATION OF AMERICA
Mr. John S. Young 633-8700
GRAY CONCRETE PIPE COMPANY
Mr. John Deal 633-7070
CROSSE AND BLACKWELL COMPANY
Mr. H. L. Reynolds 633-6800
- BORINGS**
The Interstate Division For Baltimore City Does Not Represent, Warrant, or Guarantee That The Conditions and/or Materials Actually Encountered in The Prosecuting of The Work or Any Part Thereof Will be The Same as That Shown by The Borings, The Recordings, or Any Part of Them, and If The Contractor Relies, For Any Purpose, Upon The Said Information, He Does So at His Own Risk.

TOPOGRAPHY LEGEND

	WALL OF FOUNDATION		WEDGE
	FLAGPOLE		TREE
	ALL TYPE FENCES		TREELINE
	FENCE ON RETAINING WALL		TRAIL LABELLED
	RETAINING WALL		COLLETT-EXISTING
	GUARD POSTS & TABLE		STREAM ON SHINE LINE
	POSTS ON GUARD POSTS		INTERMEDIATE CONTOUR
	STEEL GUARD RAIL		INDEX CONTOUR
	RAILROAD		DEPRESSION-NO DRAINAGE AREA
	R.R. SWITCH		B.M. S. BENCH MARK
	R.R. BUMPER		TRAVERSE POINT
	R.R. SIGNAL		PHOTOGRAMMETRIC ELEVATION
	R.R. CONTROL BOX & TRAFFIC CONTROL BOX		FIELD ELEVATION
	TRAFFIC LIGHT		AVI. AVIATION
	LIGHT POLE		B.T. BITUMINOUS
	UTILITY AND LIGHT POLE		BR. BRICK
	UTILITY LIGHT POLE WITH TRANSFORMER		CON. CONCRETE
	UTILITY POLE		E.W. EWEILING
	UTILITY POLE WITH TRANSFORMER		F.P. FLAGPOLE
	GUY POLE		F.B. FLOOFER BED
	STREET SIGN		FR. FRAME
	LIGHT POLES WITH CATWALK & TRANSFORMERS		GAR. GARAGE
	UTILITY POLES WITH CATWALK & TRANSFORMERS		G.R. GUARD RAIL
	TELEPHONE		L.P. LAND POST
	OVERHEAD TRAFFIC CONTROL SWITCH		M.F. MANUFACTURING
	FIRE HYDRANT		MAS. MASONRY
	DROP INLET		MET. METAL
	SATCH BASIN		RET. ST. RETAIL STORE
	BILLBOARD		R.W. RET. W. RETAINING WALL
	MANHOLE		S. SIGN
	GAS VENT PIPE		CHIMN. CHIMNEY
	WATER OR GAS METER - WATER METER		STN. STATION
	FIRE OR POLICE CALL BOX, CALL BOX OR SIGNAL BOX		STY. STONE
	GRATE		STY. STYRENE
	UNDERGROUND PIPE		TRANSFORMER
	CELESTIAL ENTRANCE		B.F. B.F. BUILDING OR TANK ELEVATION
	NO DIMENSIONS LABELLED		PLACED-REFRAC. DITCH
	R.R. CROSSING SET		DITCH-PROPOSED
	UTILITY LIGHT POLE WITH FIRE OR POLICE BOX		DITCH-EXISTING
	RAB. OR SURVEY LINE		DITCH-NO GRADE ELEVATION
	DITCH-SEED AND MULCH		DITCH-NO GRADE ELEVATION
	DITCH-SOILS BORING		DITCH-NO GRADE ELEVATION
	STEEL PAVED		WORK
	APPROVED LIGHT POLE NAME & STANDARD		
	BALTIMORE CITY MONUMENT		

REVISIONS	CONSULTANT	CITY OF BALTIMORE DEPARTMENT OF PUBLIC WORKS & INTERSTATE ROUTE 95 EASTERN AVENUE INTERCHANGE	STATE ROADS COMMISSION OF MARYLAND INTERSTATE DIVISION FOR BALTIMORE CITY	
	KNOERLE, BENDER, STONE & ASSOC., INC. AND MATZ, CHMOS & ASSOC., INC. CONSULTING ENGINEERS 341 N. CALVERT STREET BALTIMORE, MARYLAND 21202		DRAWN BY: E.P.D. TRACED BY: L.P.F.	DES. BY: D.E.S. CHK. BY: S.W.H.
		SCALE: AS SHOWN	DATE: 4-20-70	SHEET NO. 22 OF 113

REV. NO.	DATE	BY	CHKD. BY	TOTAL SHEETS
1	MD 1-25-43	W.S.	W.S.	23

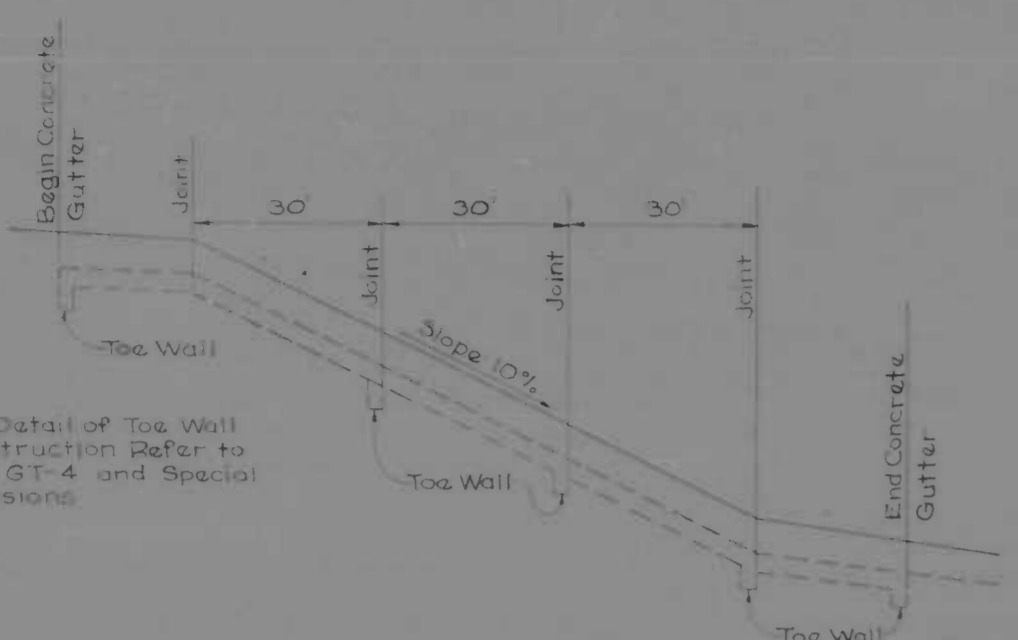

Note: For Detail of Toe Wall Construction Refer to Std. GT-4 and Special Provisions.

TYPICAL LONGITUDINAL SECTION FOR 5" CONCRETE GUTTER
Not to Scale

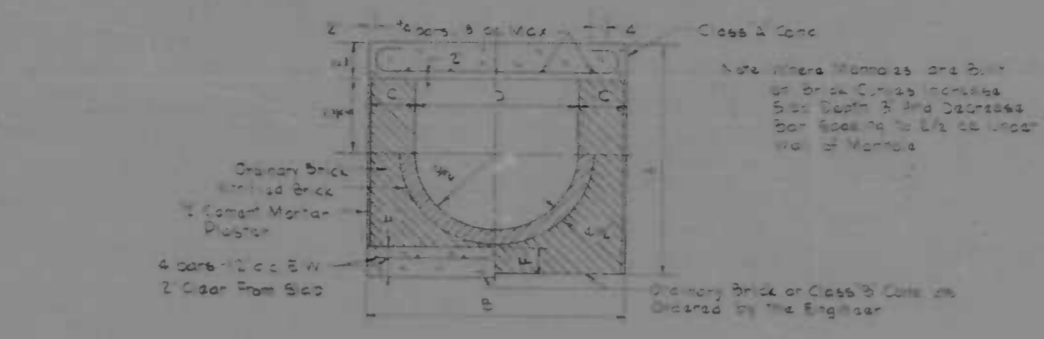

STANDARD BRICK AND CONCRETE CURVE
Not to Scale

DIMENSIONS										
D	A	B	C	E	F	G	H	I	J	STEEL
24	3-3	3-6	9	8	4 1/2	6	6	6	6	1/2 bars @ 0 c.c.
27	3-6	3-9	9	8	4 1/2	6	6	6	6	1/2 bars @ 8 c.c.
30	3	4-0	9	8	4 1/2	6	6	6	6	1/2 bars @ 7 c.c.
33	4-2	4-5	9	8	4 1/2	6	6	6	6	1/2 bars @ 6 c.c.
36	4-5	4-6	9	8	4 1/2	6	6	6	6	1/2 bars @ 5 c.c.
42	5-3	5-6	9	8	4 1/2	6	6	6	6	1/2 bars @ 4 c.c.
48	5-9	6-2	9	8	4 1/2	6	6	6	6	1/2 bars @ 3 c.c.
54	6-3	6-8	9	8	4 1/2	6	6	6	6	1/2 bars @ 2 c.c.
60	6-9	7-2	9	8	4 1/2	6	6	6	6	1/2 bars @ 1 c.c.

QUANTITIES PER LINEAR FOOT				
SIZE	CLASS CONC.	CRD BRICK	HT BRICK	STEEL
24	0.084 cu. yds.	0.1724 cu. yds.	0.258 cu. yds.	7.235 lbs.
27	0.0926 cu. yds.	0.192 cu. yds.	0.273 cu. yds.	8.934 lbs.
30	0.0988 cu. yds.	0.212 cu. yds.	0.287 cu. yds.	10.349 lbs.
33	0.1049 cu. yds.	0.232 cu. yds.	0.302 cu. yds.	12.286 lbs.
36	0.1111 cu. yds.	0.252 cu. yds.	0.316 cu. yds.	14.96 lbs.
42	0.124 cu. yds.	0.324 cu. yds.	0.365 cu. yds.	16.576 lbs.
48	0.1303 cu. yds.	0.398 cu. yds.	0.414 cu. yds.	20.676 lbs.
54	0.1358 cu. yds.	0.46 cu. yds.	0.463 cu. yds.	20.344 lbs.
60	0.1412 cu. yds.	0.524 cu. yds.	0.512 cu. yds.	27.3 lbs.

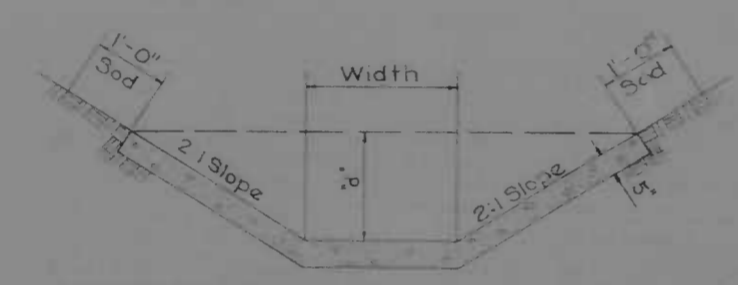

Note: For Values of Width and 's' See Plans.
Note: Toe Wall to be Constructed at 30' Intervals on All Concrete Ditches Having Grades 10% or Greater. See Detail This Sheet.

CONCRETE INLET AND OUTLET DITCH
Not to Scale

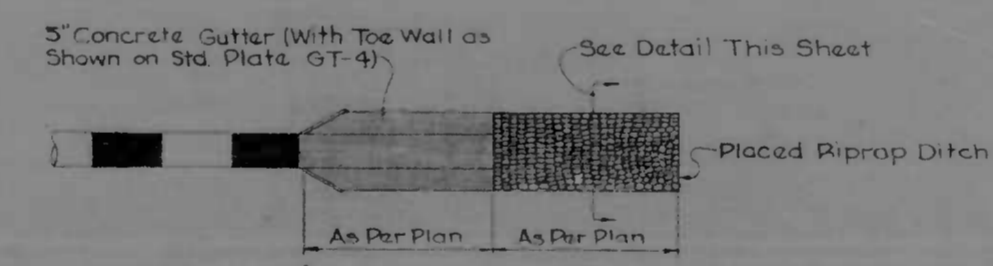

PLACED RIPRAP DITCH LOCATION
Not to Scale

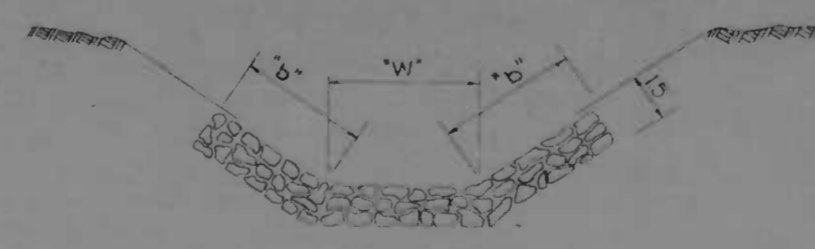

PLACED RIPRAP DITCH
Not to Scale
(See Special Provisions)

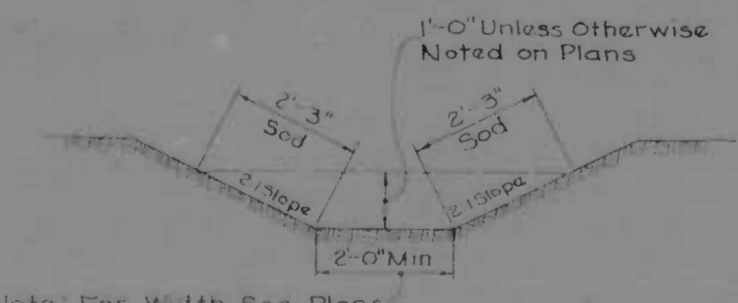

Note: For Width See Plans.
SOD SIDE DITCH FILL AREAS & SOD INLET & OUTLET DITCH
Not to Scale

DRAINAGE NOTES

- EXISTING UTILITIES**
Obstructions Shown on The Drawings Are For The Convenience of The Contractor Only And The I.O.B.C. Does Not Warrant or Guarantee The Correctness of The Information Given Nor For Any Construction Difficulty Arising Therefrom. The Contractor Must Verify All Such Information to His Satisfaction.
- GAS & ELECTRIC COMPANY UTILITIES**
Before Starting Work The Contractor Shall Call 234-5581 For a Gas & Electric Company Representative. Call Three (3) Days Before Starting Work.
- CHESAPEAKE & POTOMAC COMPANY UTILITIES**
Three (3) Days Before Starting Work The Contractor Shall Notify The C & P Telephone Company, 583-1234.
- INLET CONNECTIONS**
Depth of Inlet Connections in Streets at Curb Line to be as Shown by Invert Elevations. No Payment Will be Made for Greater Depth Unless Specifically Ordered by The Engineer. Additional Depth for Pipe Excavation Shall be Paid For as "Class 3 Excavation for Incidental Construction."
- DRAINAGE STRUCTURES**
The Locations and Inverts of The Drainage Structures are Subject to Modification as May be Required by Field Conditions as Directed by The Engineer. Type Double "S" Compartment Inlets Shall be Undepressed.
- EXISTING DRAINAGE STRUCTURES**
All Salvaged Items Shall Become The Property of The Contractor, Unless Otherwise Noted in The Special Provisions.
- PIPES IN FILL**
When a Pipe Structure is to be Laid on Existing Ground or on or Under Fill, Embankment Shall be Constructed to a Height of at Least Nine (9) Inches Above, But Not More Than Three (3) Feet Above Top of Pipe And Then a Trench Excavated to Receive The Pipe Backfilling of Trenches Shall be in Accordance With Article 31.07 of The Specifications.
- INLET CONSTRUCTION**
Inlets May be Constructed of Brick or Reinforced Concrete. Top 5" of Walls May be Brick Masonry. Additional Brick May be Used to Bring The Grate to Grade if Required. Reinforcement to be #4 (1/2" dia) Bars, 2 Ways. Reinforcement Required on Outside as Well as Inside of Walls Below 2'-0" Spacing Same as for Inside Wall. Place 1/4" Expansion Material of Same Type Approved for Pavement Between The Frame and Abutting Rigid Pavement and Between Ends of Inlet Curb & Normal Curb.
- HORIZONTAL & VERTICAL CONTROL**
Grid System: All Bearings, North Arrows, & Coordinates are Based on The City of Baltimore Survey Control System.
Level Datum: All Elevations are Based on The City of Baltimore Survey Control System.
- MANHOLES**
Manholes on Drains 36" and Larger in Diameter Shall Have 30" Frame & Cover. Pipe Inverts Shown on Profiles are at E. Manhole.
- PAVEMENT CROSS SLOPE**
Grates for Underdepressed inlets shall be set on the cross slope indicated in the charts on the plans.
- MODIFIED S' COMBINATION INLET**
Inlet Bottom to be Channeled When Connecting Pipe Through Inlets. See Detail Sheet No. 29.
- R.C.P. CLASS**
All Reinforced Concrete Pipe shall be as indicated on the plans and conform to the Tentative Specifications for Reinforced Concrete Pipe, ASTM C76-65 T.
- PIPE JOINTS**
Storm Drain and Sanitary Sewer Pipe to be Rubber Gasket Joint and Inlet Connection Pipe to be Bell & Spigot Joint. See Special Provisions Relative to Jacked Pipe.
- LOCATION OF DRAINAGE STRUCTURES**
Locations of Proposed Manholes and Special Structures are Described by The Distance from The Project & Construction to The Intersection Point of The Horizontal and Vertical Centerlines of The Structure.
Locations of Curb inlets are Described by The Distance from The E. Construction to The Face of The Curb at The Transverse Centerline of The Inlet. The Top of Grate Elevations Given are at The Same Point.

REVISIONS	CONSULTANT	CITY OF BALTIMORE DEPARTMENT OF PUBLIC WORKS	STATE ROADS COMMISSION OF MARYLAND INTERSTATE DIVISION FOR BALTIMORE CITY
	KIMBLE, BENDIS, STONE & ASSOC., INC. AND WATT, CHILDS & ASSOC., INC. CONSULTING ENGINEERS 341 N. DEXTER STREET BALTIMORE, MARYLAND 21202	INTERSTATE ROUTE 95 EASTERN AVENUE INTERCHANGE	DRAWN BY: J.S.M. DES BY: J.S.M. CHECK BY: J.S.M. F.P. NO. 1-95-430136 S.R.C. NO. DC 245-29-815 BALTO. CITY NO. 1359
		SCALE: AS SHOWN	DATE: 10-6-65

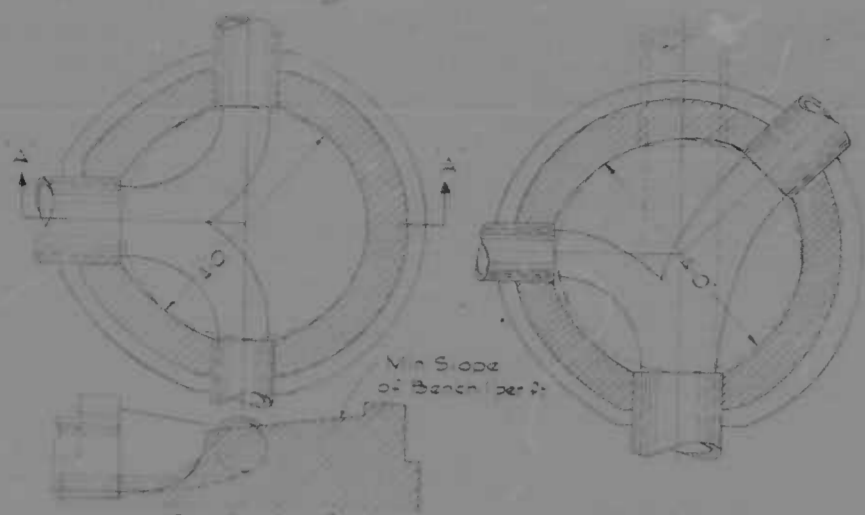

Section A-A
STANDARD CHANNEL No. 1

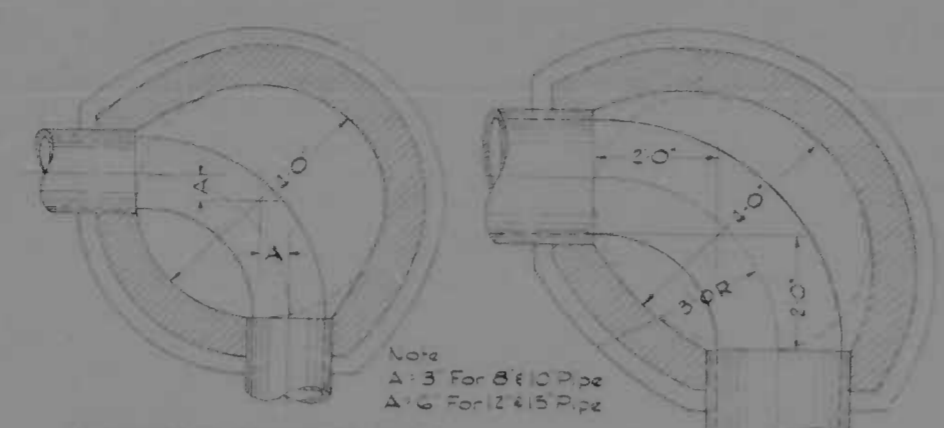

STANDARD CHANNEL No. 5
(For 8, 10, 12 & 15 Pipe)
STANDARD CHANNEL No. 6
(For 18, 21 & 24 Pipe)

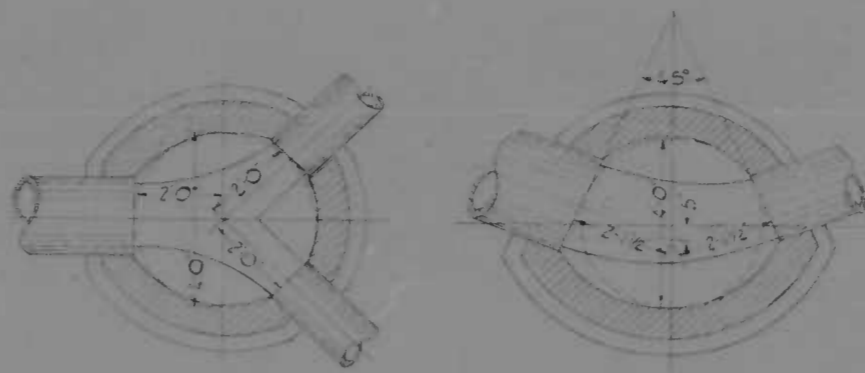

STANDARD CHANNEL No. 9 **STANDARD CHANNEL No. 10**
Scale: 3/8\"/>

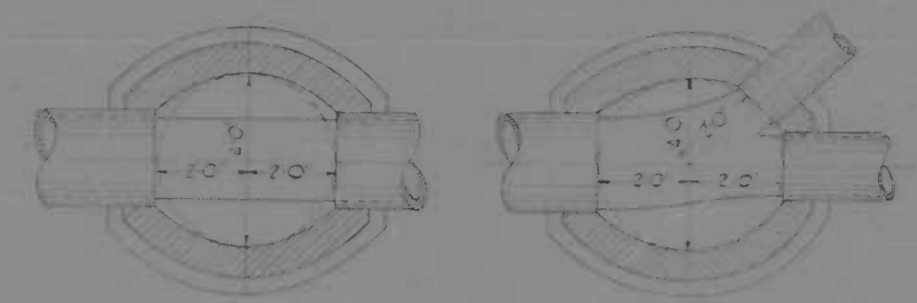

STANDARD CHANNEL No. 11 **STANDARD CHANNEL No. 12**
Scale: 3/8\"/>

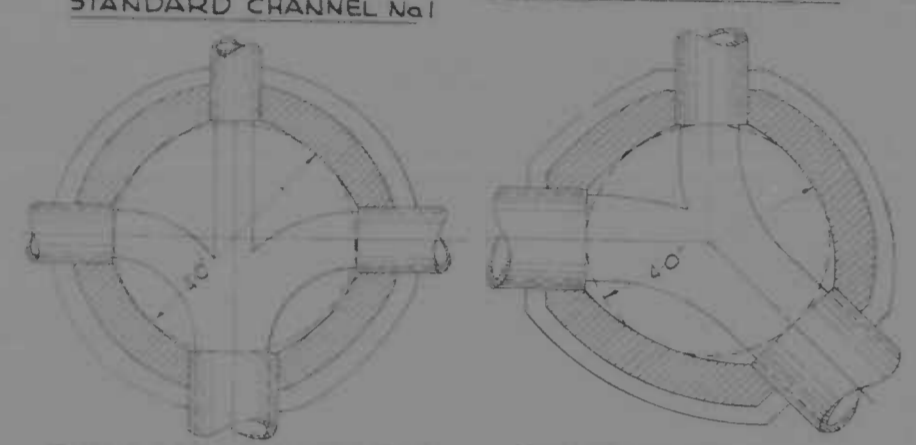

STANDARD CHANNEL No. 3 **STANDARD CHANNEL No. 4**
Scale: 1/2\"/>

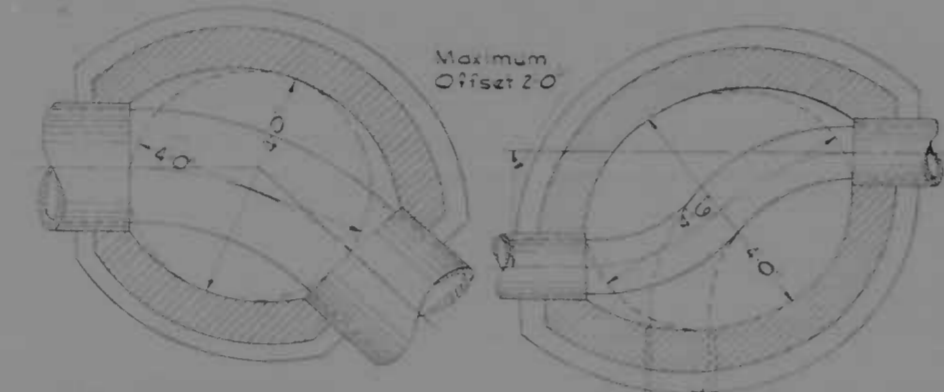

STANDARD CHANNEL No. 7 **STANDARD CHANNEL No. 8**
Scale: 1/2\"/>

Bench Height Above Outgoing Pipe Invert to be Equal to Diameter of Outgoing Pipe

TYPICAL MANHOLE CHANNELS

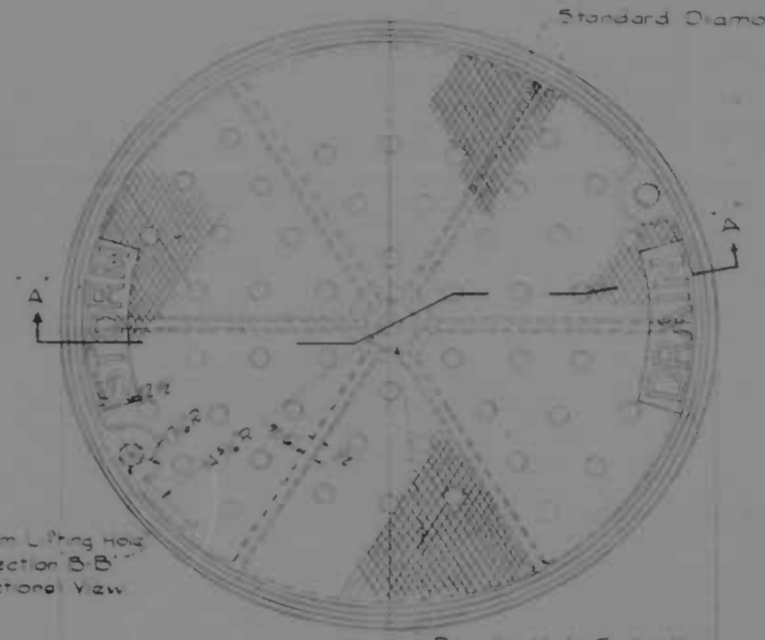

18\"/>

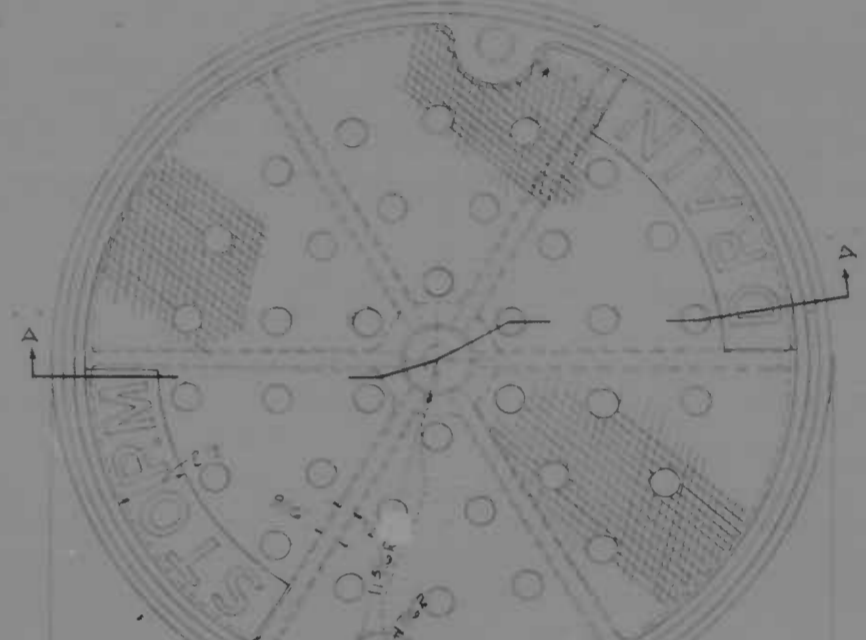

18\"/>

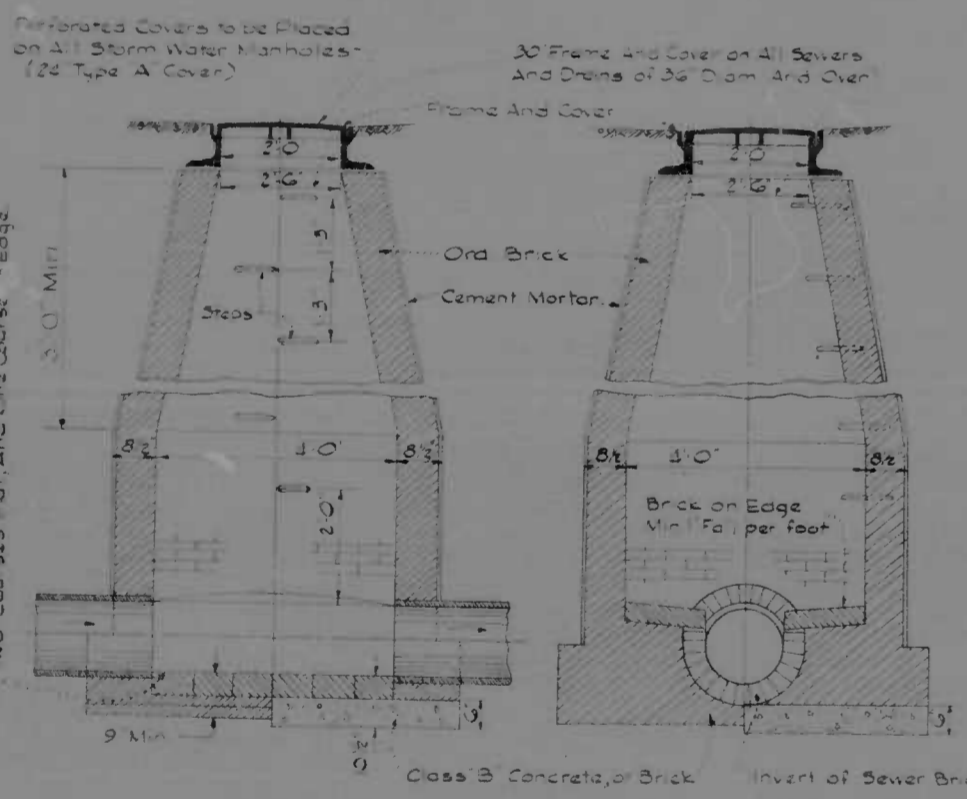

STANDARD MANHOLE
Scale: 1/2\"/>

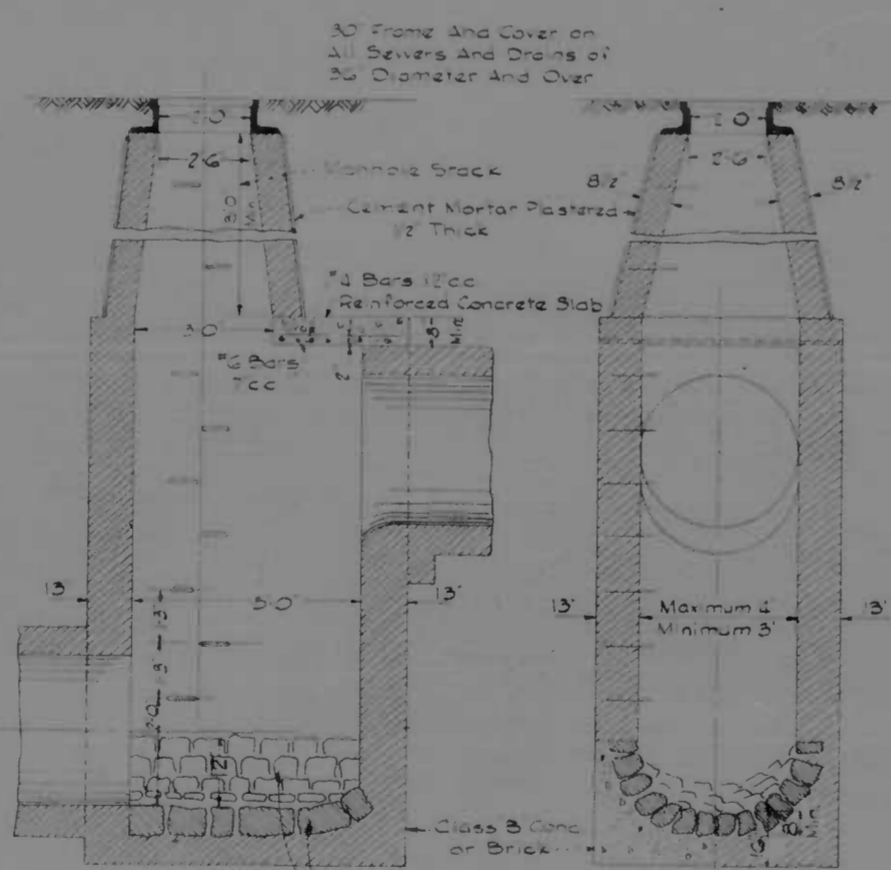

STANDARD STORM DRAIN DROP MANHOLE
Scale: 3/8\"/>

NOTE
1. If concrete slab is used, place #4 Cor. Bars 12\"/>

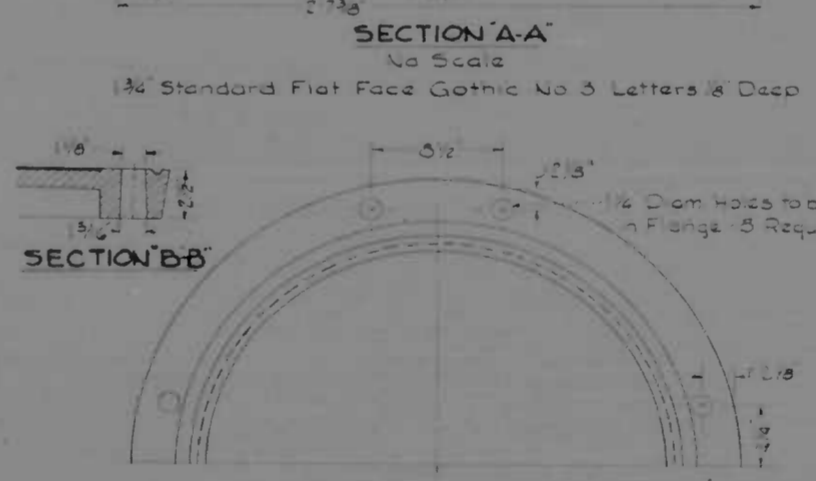

SECTION A-A
No Scale
SECTION B-B



SECTION A-A
Scale: 3/4\"/>

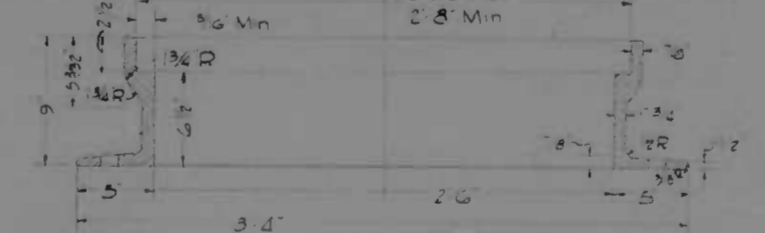

DETAIL OF 30\"/>

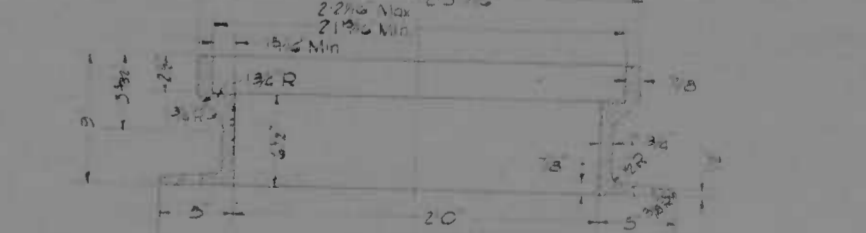

DETAIL OF 24\"/>

REVISIONS	CONSULTANT	CITY OF BALTIMORE DEPARTMENT OF PUBLIC WORKS	STATE ROADS COMMISSION OF MARYLAND INTERSTATE DIVISION FOR BALTIMORE CITY
	KNORRE, BENDER, STONE & ASSOC., INC. 441 N. CALVERT STREET BALTIMORE, MARYLAND 21202		
	PROJECT	INTERSTATE ROUTE 95 EASTERN AVENUE INTERCHANGE	DRAWN BY M.F.H. TRACED BY M.F.H. J.A.P. NO. 1-48-812/36 P.R.C. NO. B.C. 238-227-B15 BALTO. CITY NO. 1223
	DATE	9-20-70	DES. BY D.E.S. CHK. BY W.F.F.
	SCALE	AS SHOWN	SHEET NO. 24 of 113

DATE	NO.	BY	REVISION
2	MD	1-85-43, 136	25

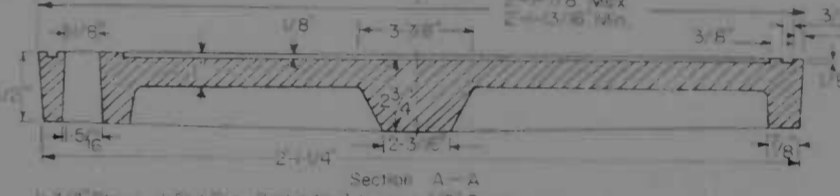
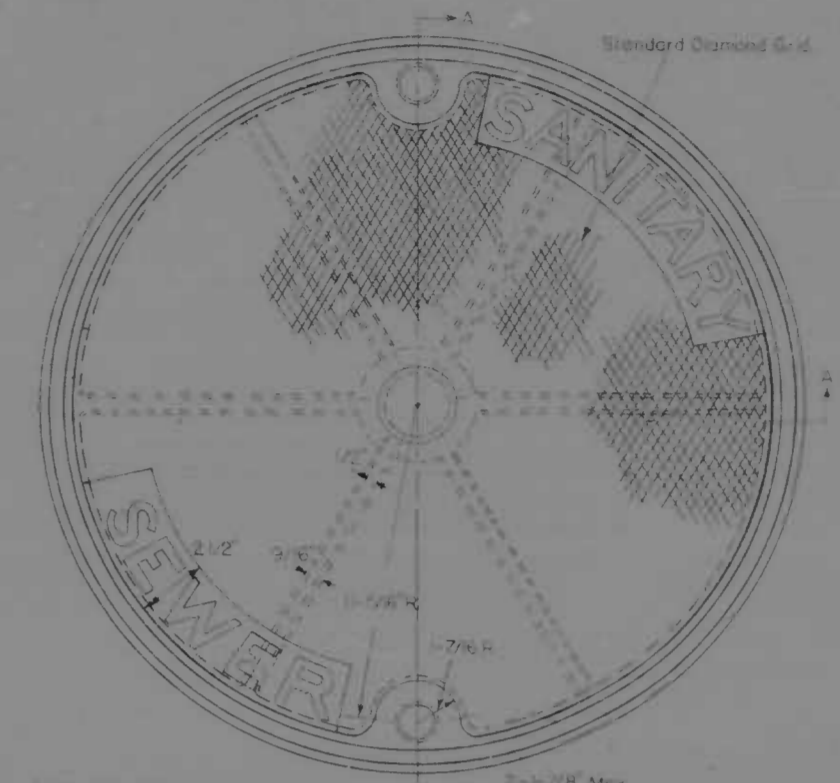
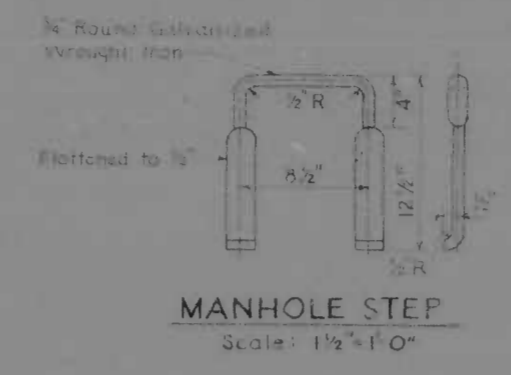
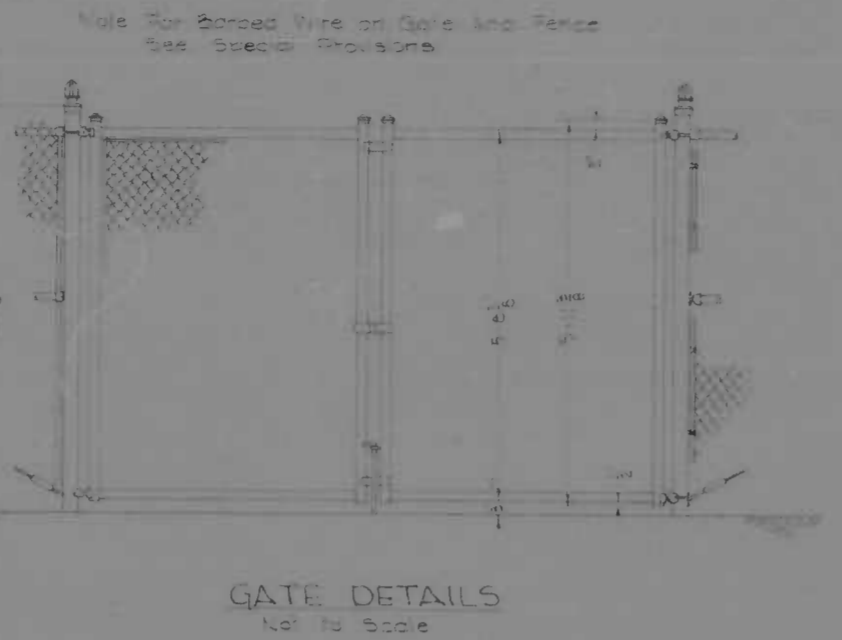
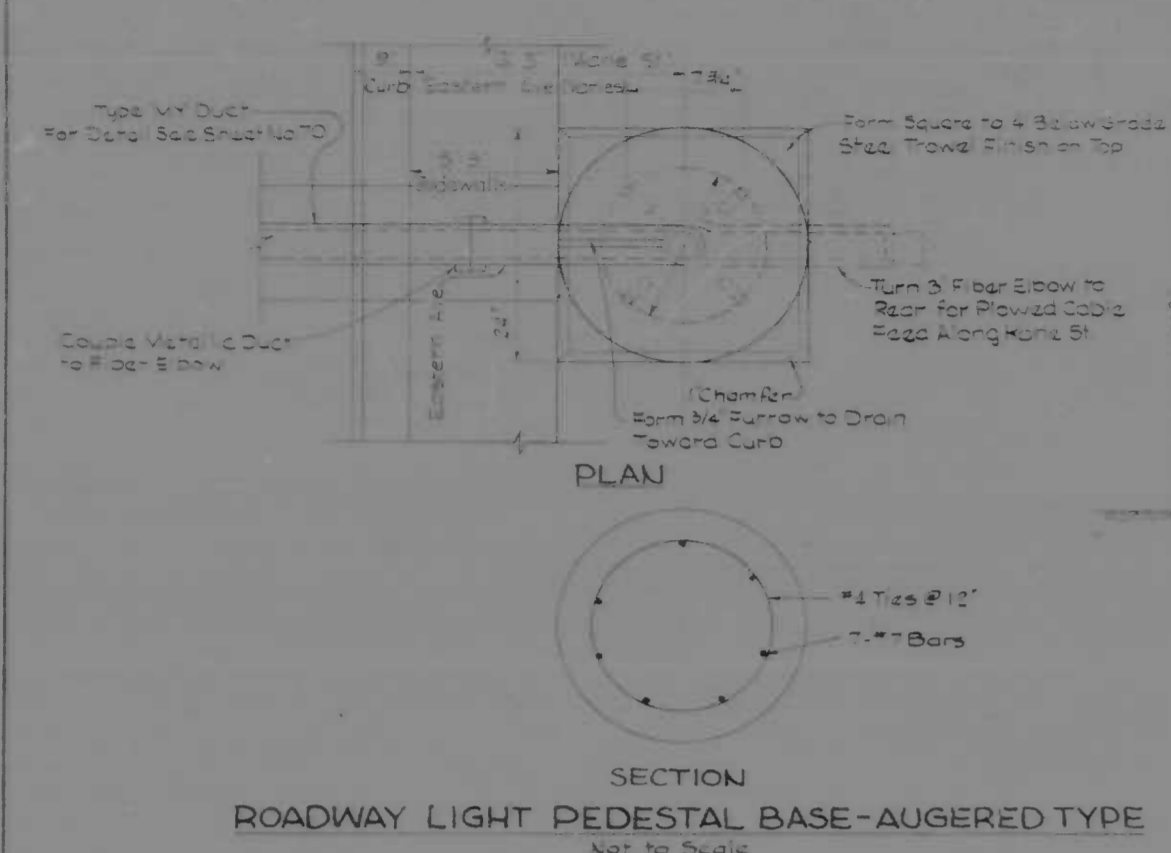

SANITARY MANHOLE COVER FOR 24" FRAME
Scale 3"=1'-0"

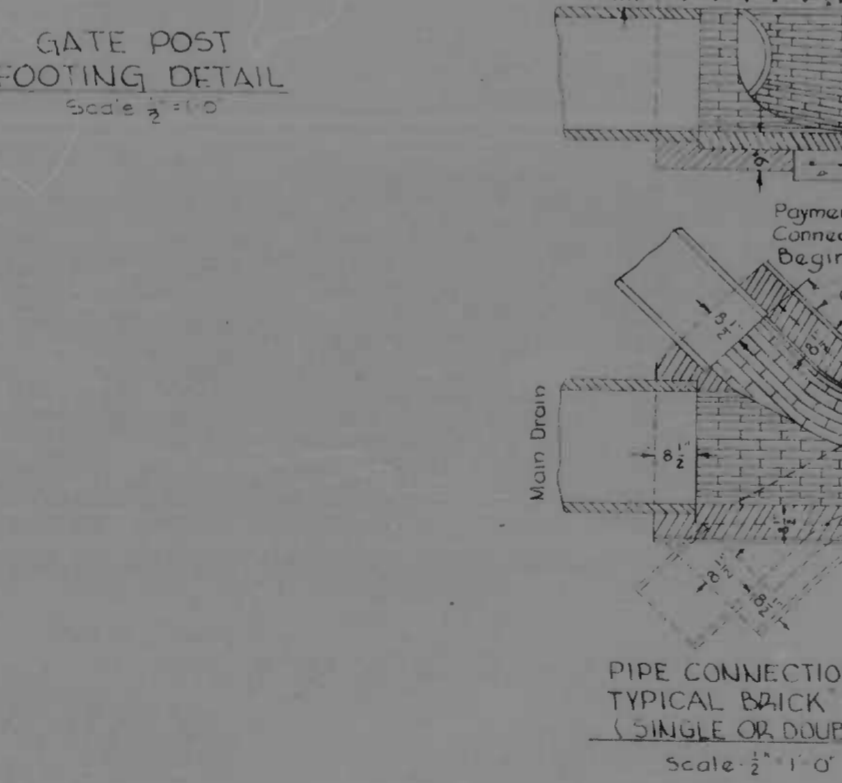
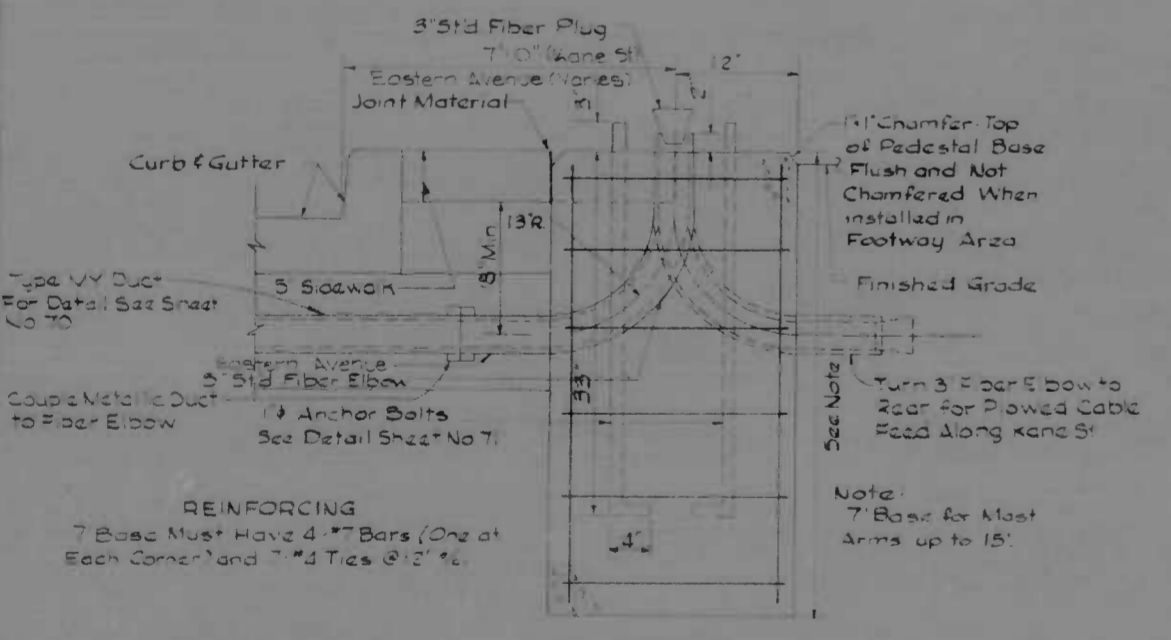
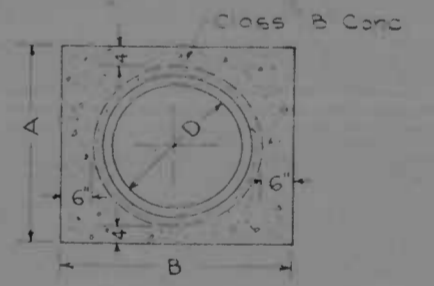
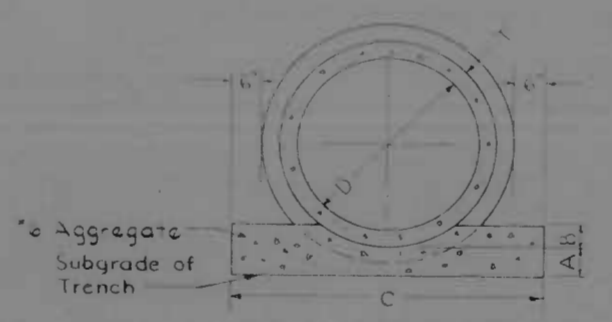
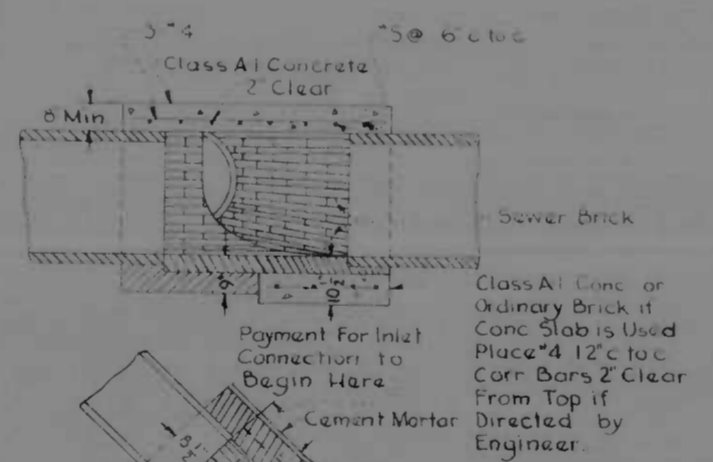
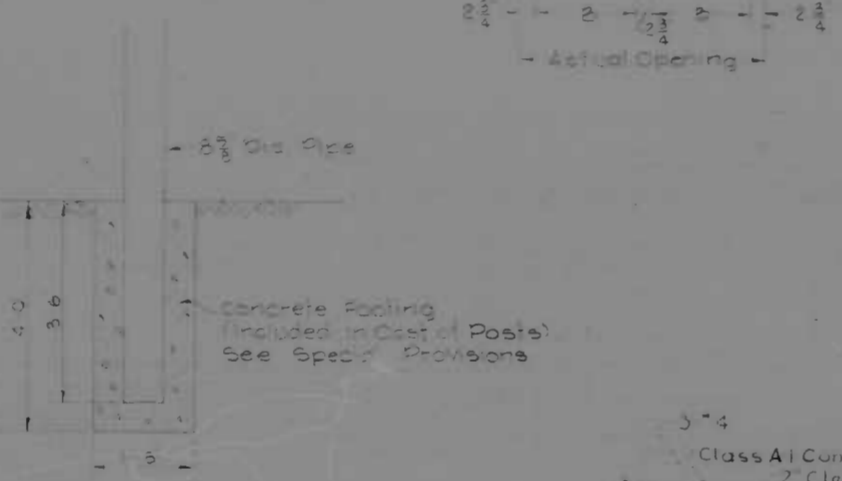
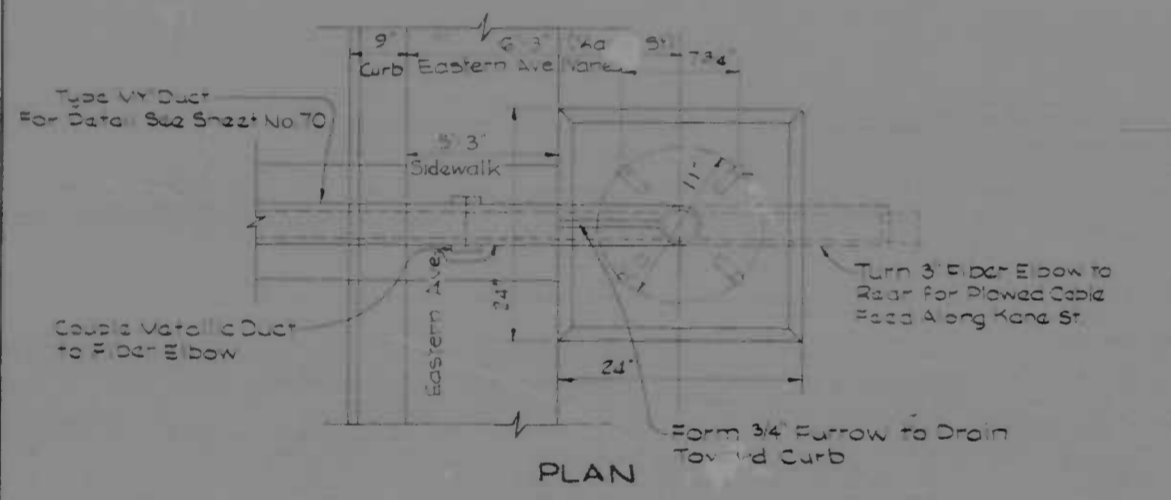

REINFORCED CONCRETE PIPE GRAVEL CRADLE
Not to Scale

DIMENSIONS					CUBIC YDS PER LIN FT
D	A	B	C	T	
IN	IN	IN	IN	IN	
15	7	6	2 1/2	2	0.0978
18	7	6	3-3/8	2 1/4	0.1084
21	7	6	3-6	2 3/8	0.1167
24	7	6	3-10	2 7/8	0.1230
27	7	6	4-1	2 7/8	0.1366
30	7	6	4-5	3	0.1479
33	7	6	4-8	2 7/8	0.1547
36	7	6	4-11	3 3/8	0.1718
42	7	6	5-9	4	0.2000
48	8	6	6-6	4 1/2	0.2103
54	8	7	7-0	5	0.2754
60	8	8	7-3	6	0.2718
66	8	8	7-9	6 1/2	0.2920

Note: Gravel Cradles to be Placed Under Storm Drain Pipes and Under Sanitary Sewer Pipes as Noted on the Plan

DIMENSIONS

D	A	B	Cu Yds Conc. Per Lin. Ft.
8"	1' 8"	2' 0"	0.0944
10"	1' 10"	2' 2 1/2"	0.1254
12"	2' 1"	2' 5"	0.1469
15"	2' 5"	2' 9"	0.1860
18"	2' 9"	3' 1"	0.2291
21"	3' 1"	3' 5"	0.2738
24"	3' 5"	3' 9"	0.3073
27"	3' 8"	4' 0"	0.3481

CONCRETE ENCASEMENT
Not to Scale

REVISIONS	CONSULTANT	CITY OF BALTIMORE DEPARTMENT OF PUBLIC WORKS	STATE ROADS COMMISSION OF MARYLAND INTERSTATE DIVISION FOR BALTIMORE CITY
	KNORLE, BENDER, STONE & ASSOC., INC. AND MATZ, CHILDS & ASSOC., INC. CONSULTING ENGINEERS 341 N. BALVERT STREET BALTIMORE, MARYLAND 21202	INTERSTATE ROUTE 98 EASTERN AVENUE INTERCHANGE	DRAWN BY E.P.D. TRACED BY E.P.D. F.A.P. NO. 1-95-43, 136 S.R.C. NO. BC 246-29-BIS BALTO. CITY NO. 1789
		SCALE AS SHOWN	DATE 4-20-75
			SHEET NO. 25 OF 113

PROJECT NO.	STATE	FED. AID DIST. NO.	SHEET NO.	TOTAL SHEETS
2	MD	11-95-4152136	26	113

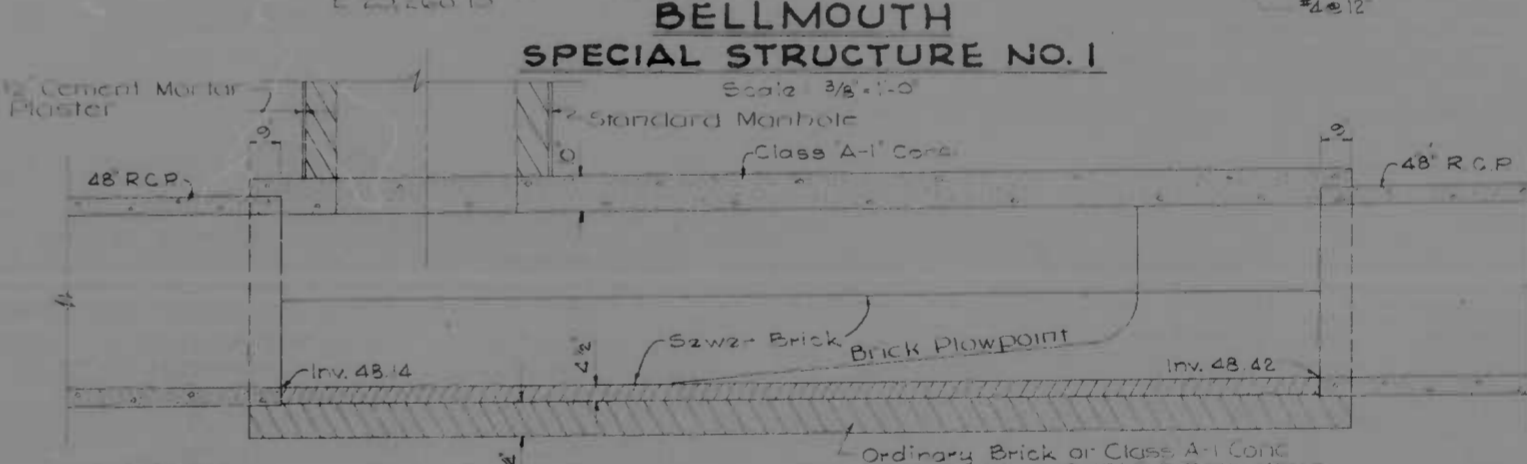
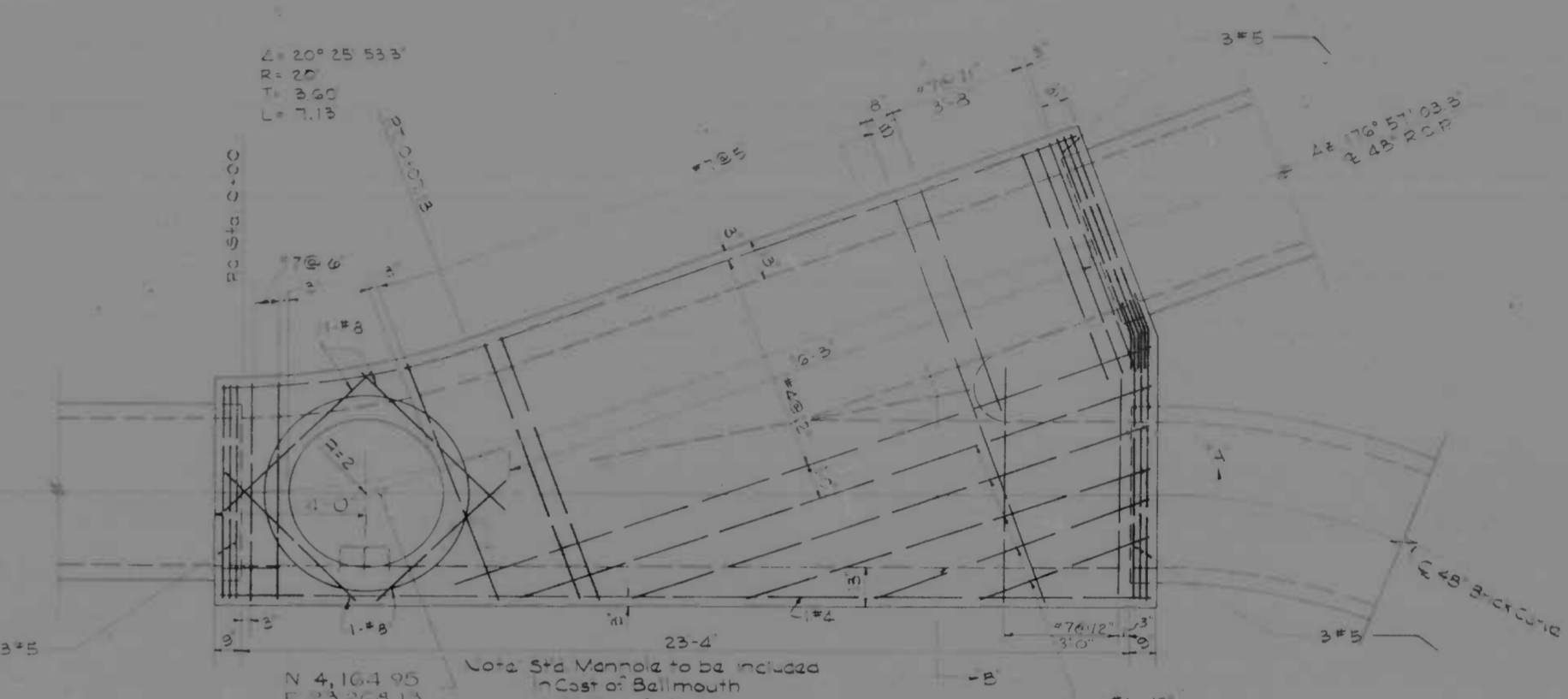
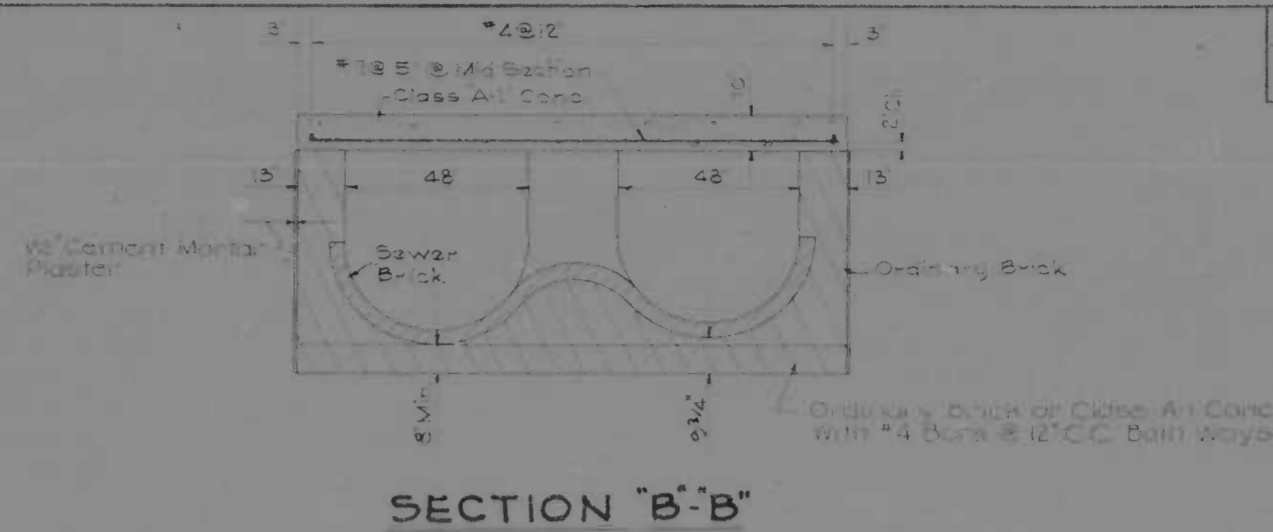
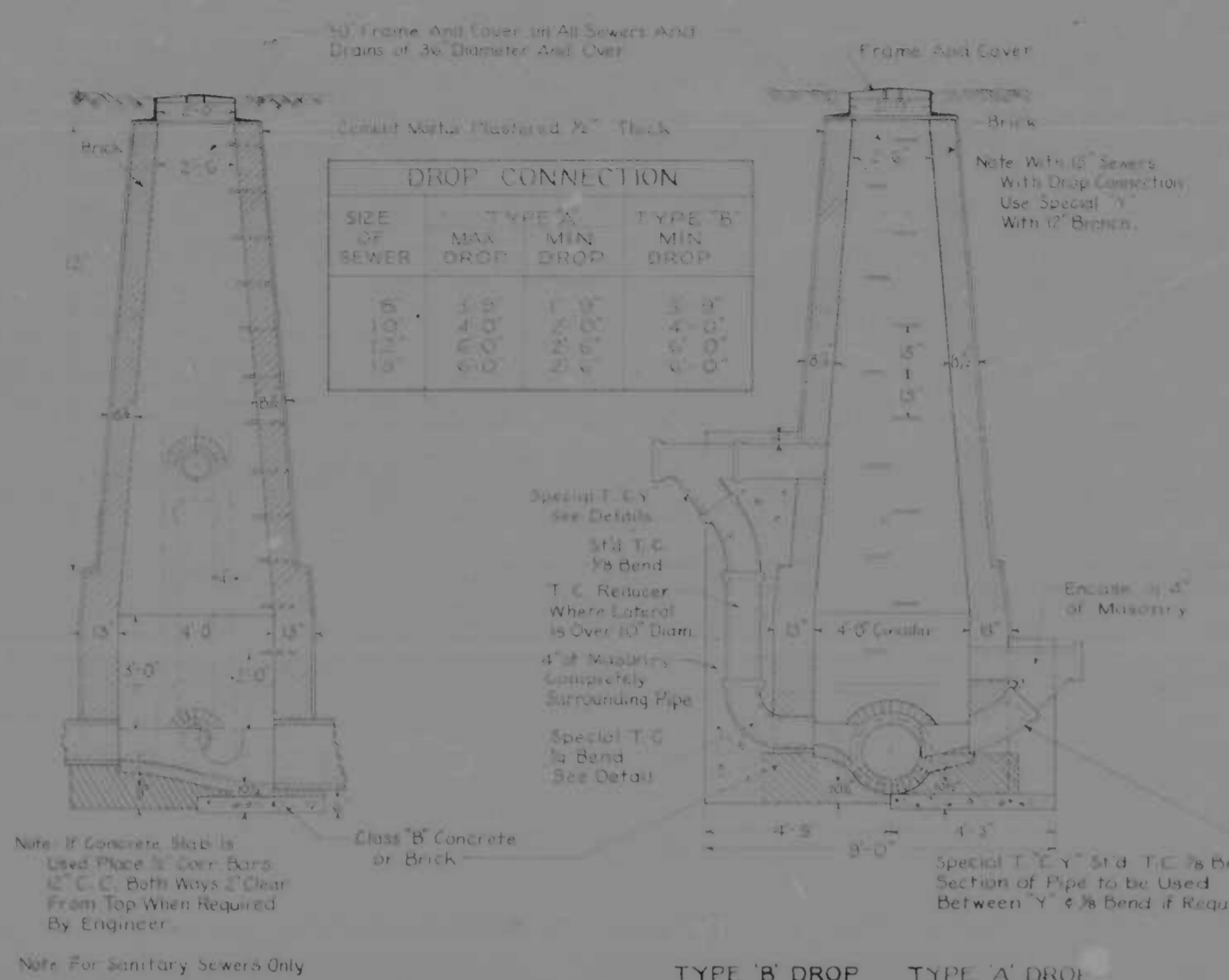

SANITARY SEWER TYPE 'A' DROP CONNECTION

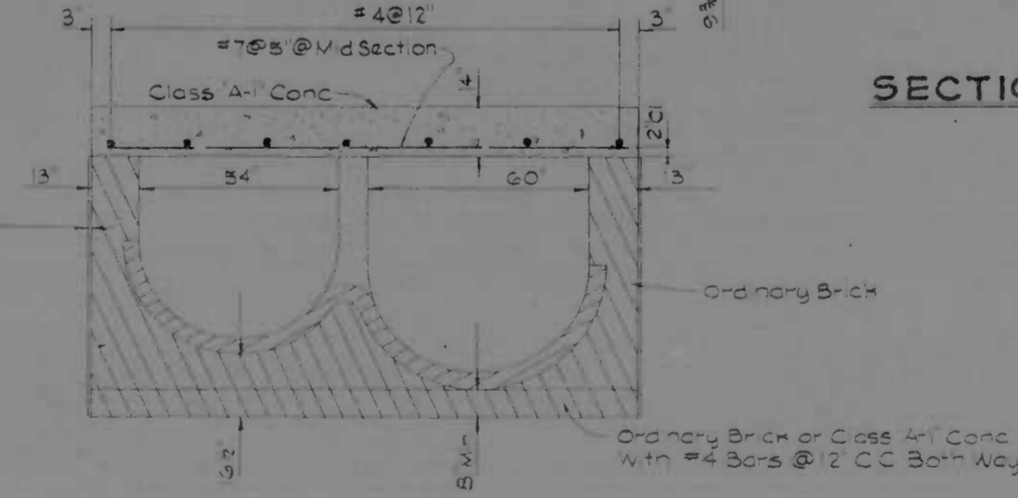
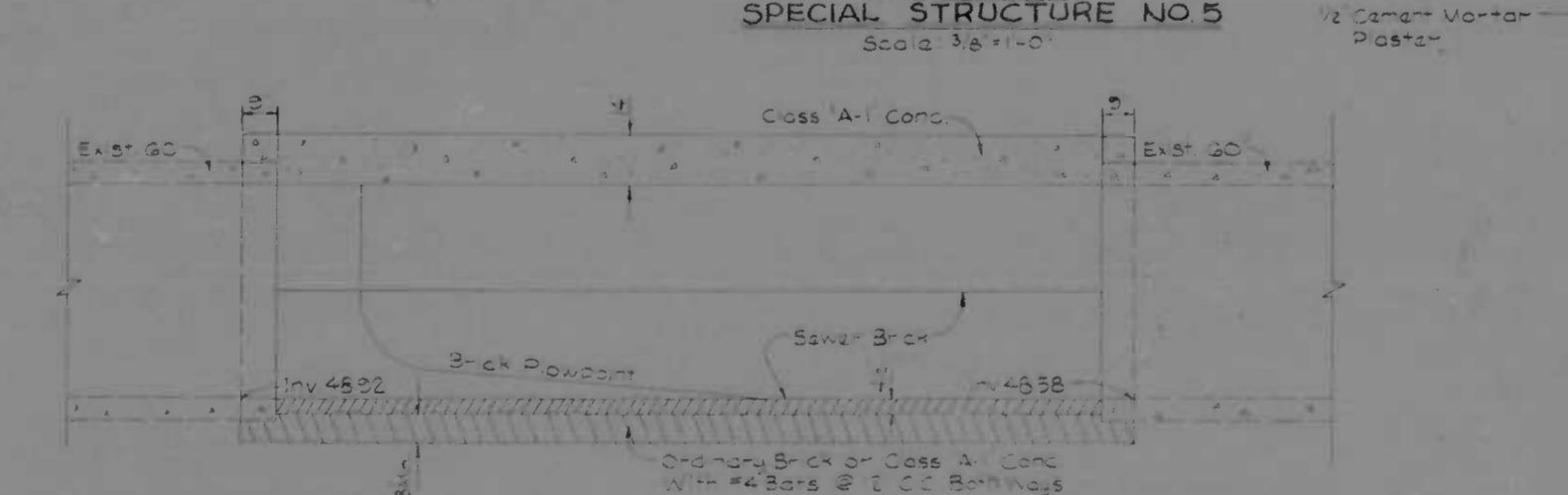
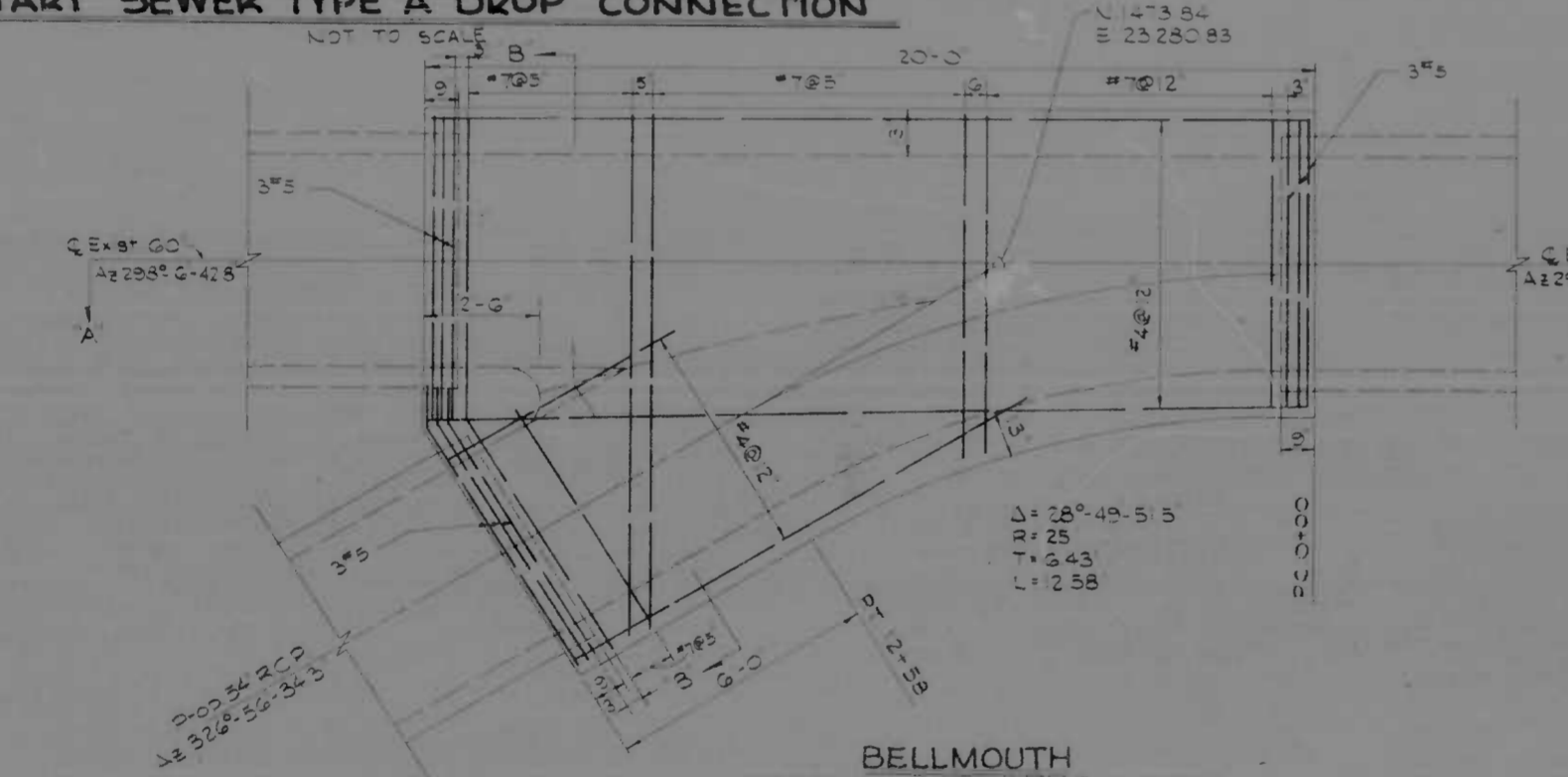

REVISIONS	CONSULTANT	CITY OF BALTIMORE DEPARTMENT OF PUBLIC WORKS	STATE ROADS COMMISSION OF MARYLAND INTERSTATE DIVISION FOR BALTIMORE CITY
	KNOWLE, BENDER, STONE & ASSOC., INC. NATZ, CHURS & ASSOC., INC. CONSULTING ENGINEERS 841 N. CALVERT STREET BALTIMORE, MARYLAND 21202	INTERSTATE ROUTE 95 EASTERN AVENUE INTERCHANGE	DRAWN BY: ELM CHECKED BY: ELM DES. BY: DE S. DATE: 10-5-59
		SCALE: AS SHOWN	SHEET NO. 26 OF 113

NO.	DATE	BY	CHKD.	APP.
2	MO. 196-5-30	127	113	

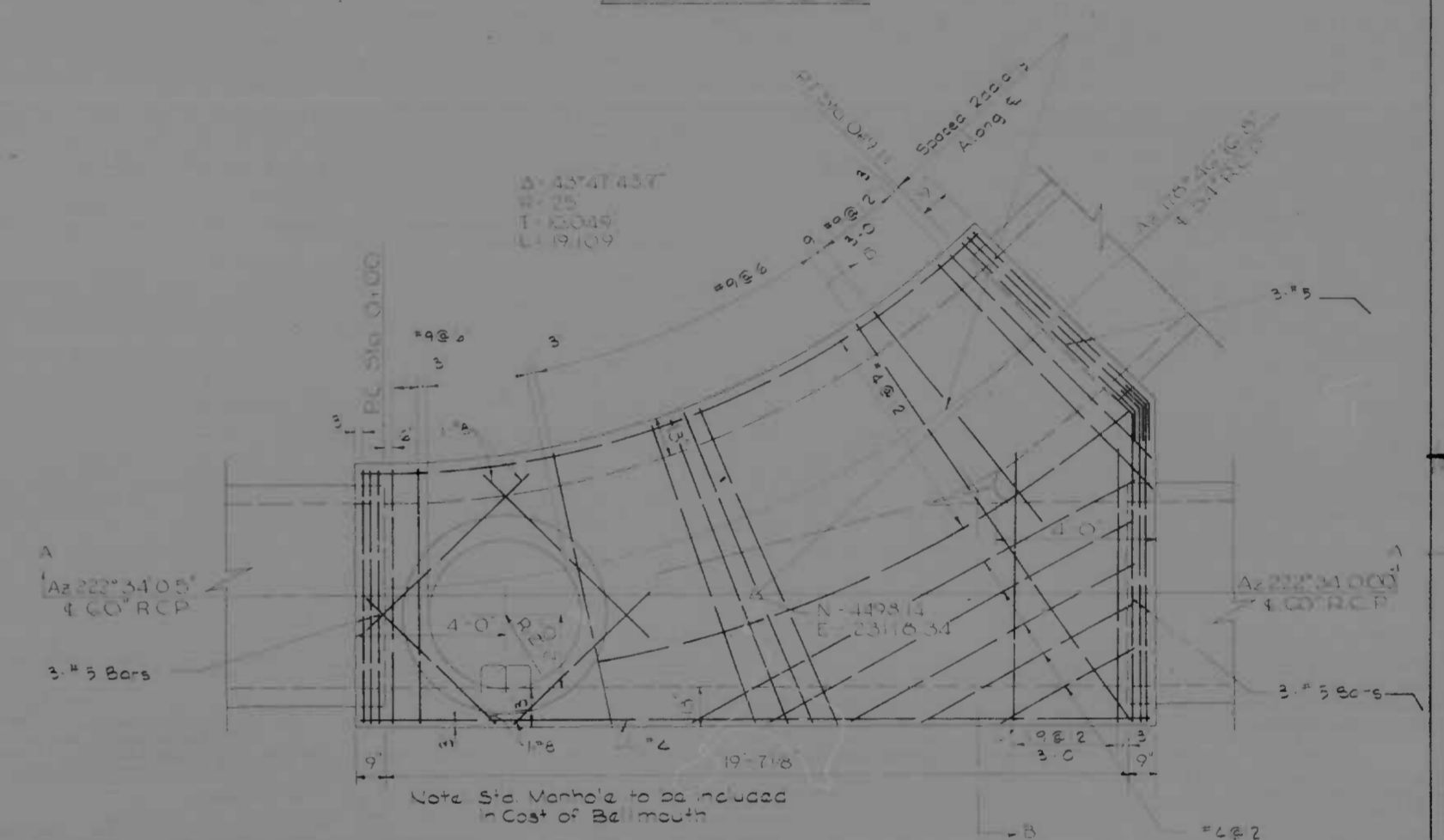
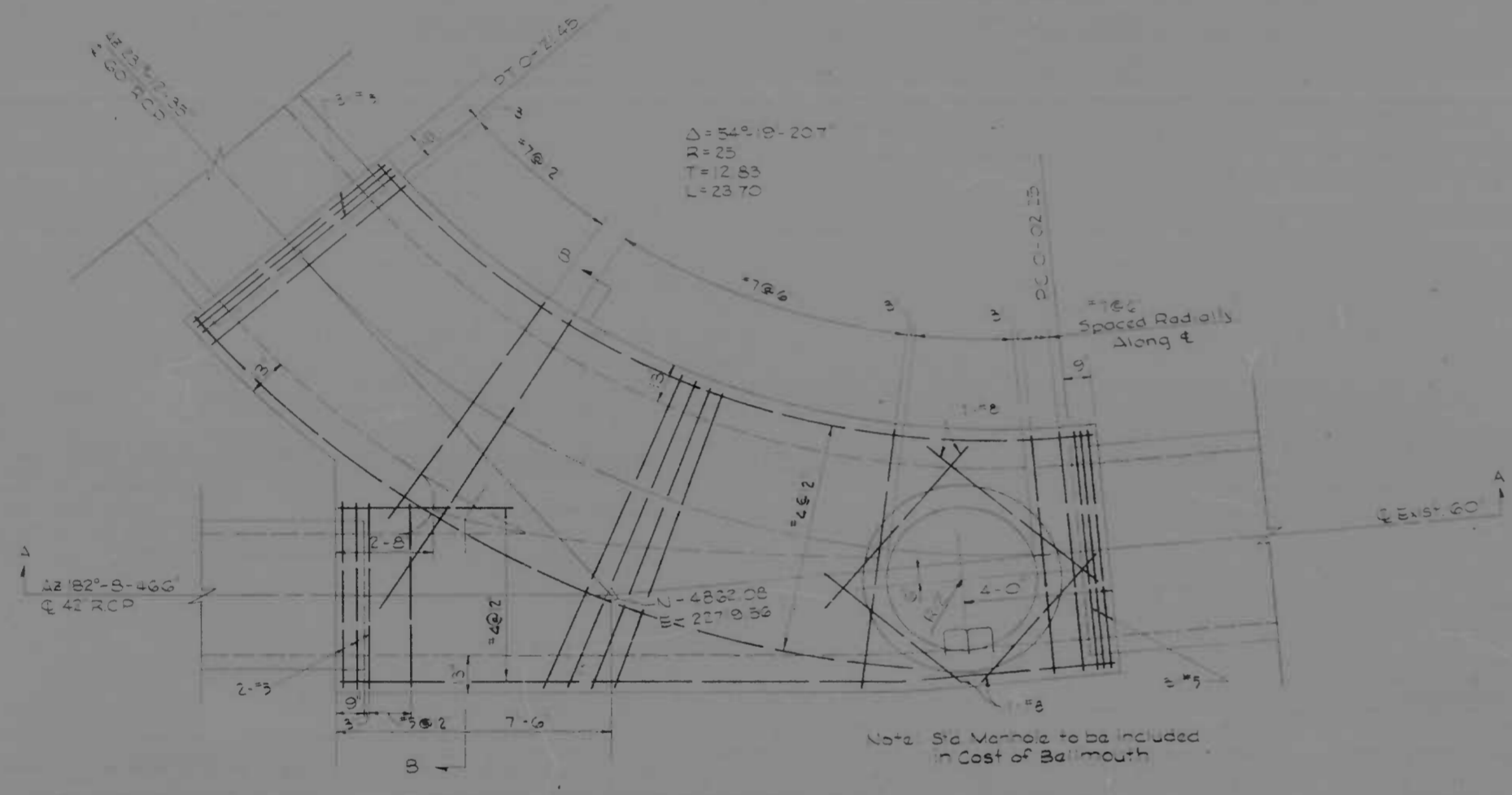
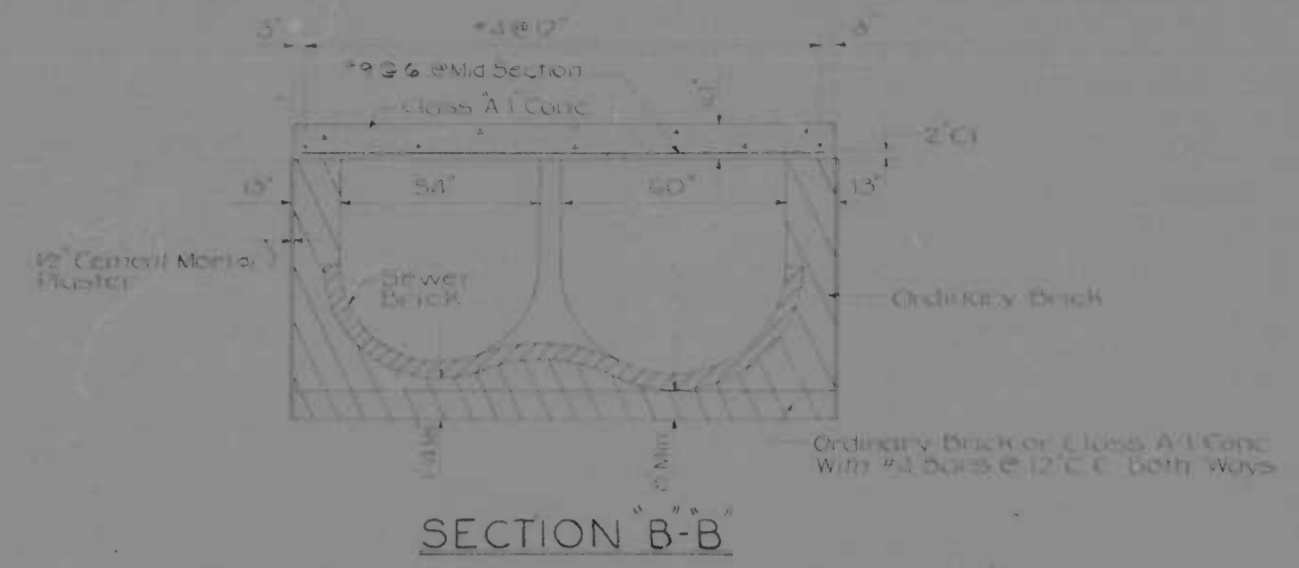
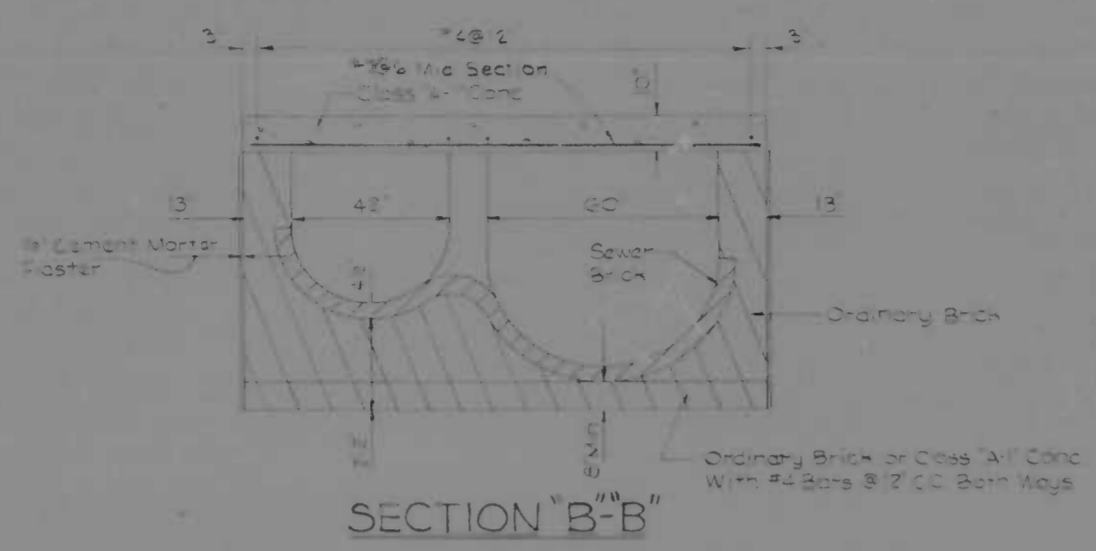

BELLMOUTH
SPECIAL STRUCTURE NO. 3

BELLMOUTH
SPECIAL STRUCTURE NO. 2

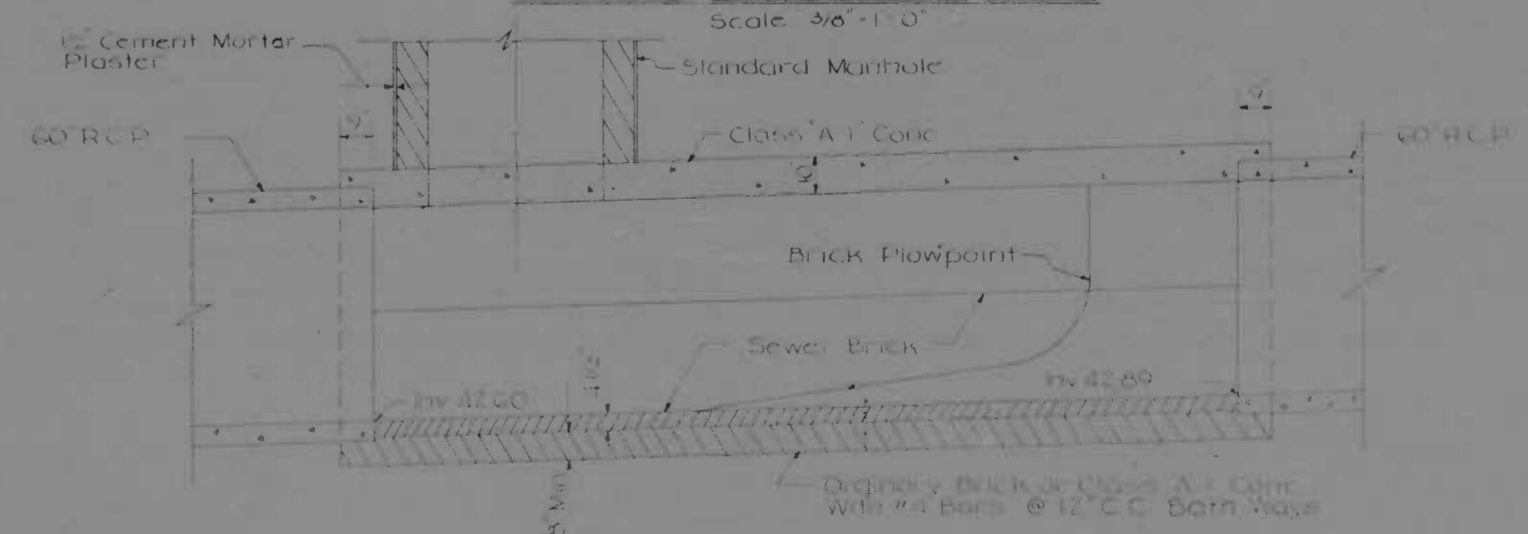
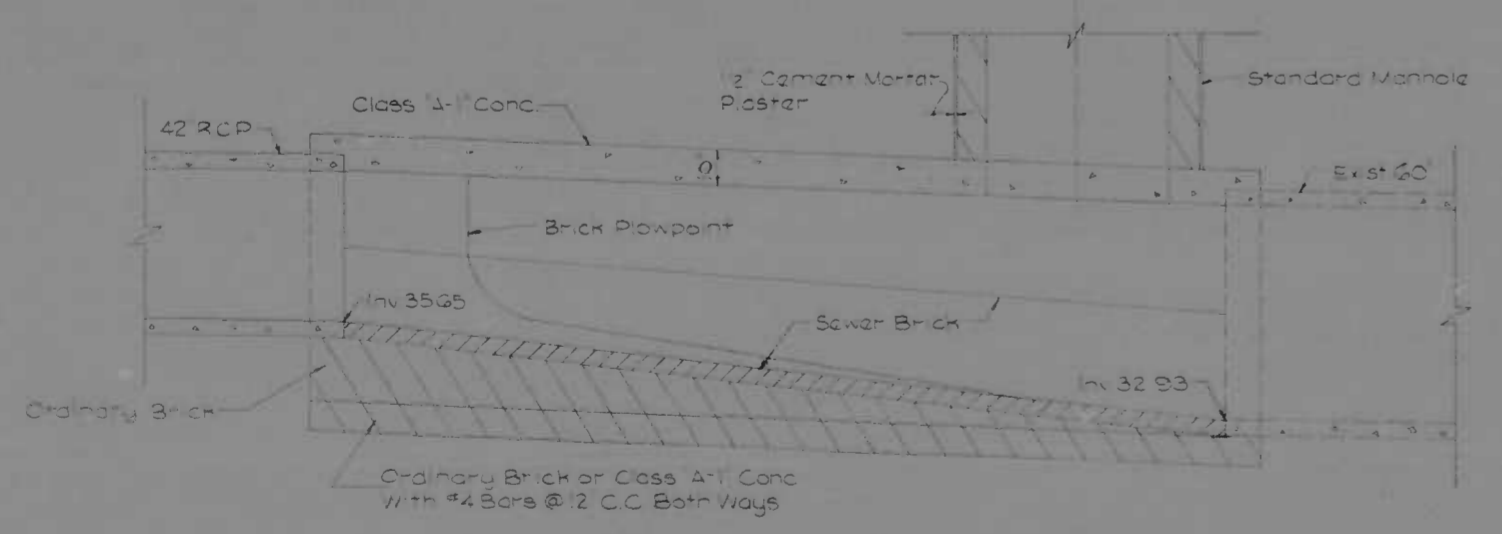

SECTION A-A

SECTION A-A

REVISIONS	CONSULTANT	CITY OF BALTIMORE DEPARTMENT OF PUBLIC WORKS	STATE ROADS COMMISSION OF MARYLAND INTERSTATE DIVISION FOR BALTIMORE CITY	
	KINDLER, BENDER, STONE & ASSOC., INC. BALTIMORE, MARYLAND 21202		INTERSTATE ROUTE 95 EASTERN AVENUE INTERCHANGE	DRAWN BY: J.F.F. CHECKED BY: J.F.F. DATE: 4-20-70
		SCALE: As Shown	DATE: 4-20-70	SHEET NO. 27 OF 13

NO.	DATE	BY	REVISIONS
2	MD	195-423135	28 113

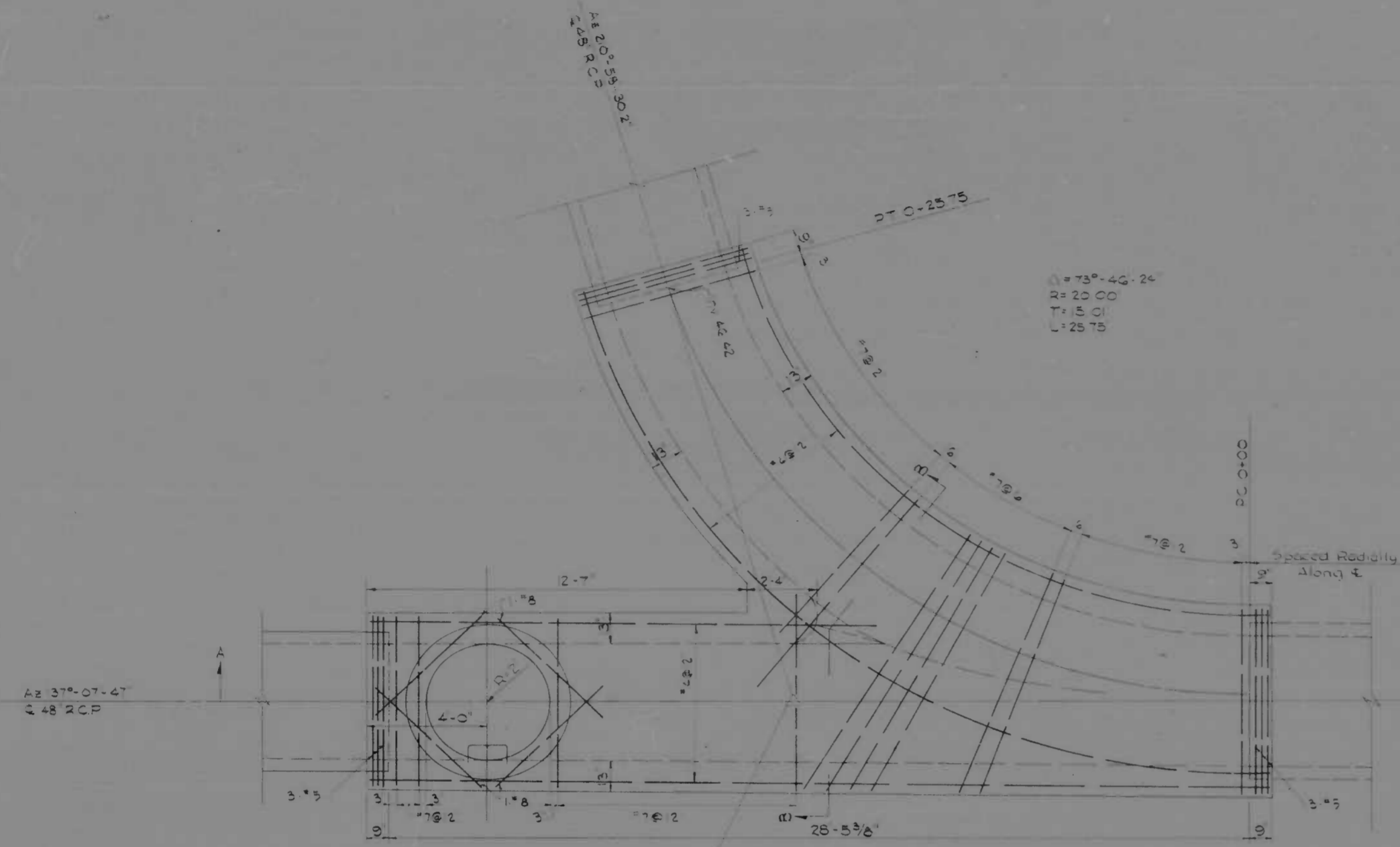

BELLMOUTH SPECIAL STRUCTURE NO. 4
Scale: 3/8" = 1'-0"

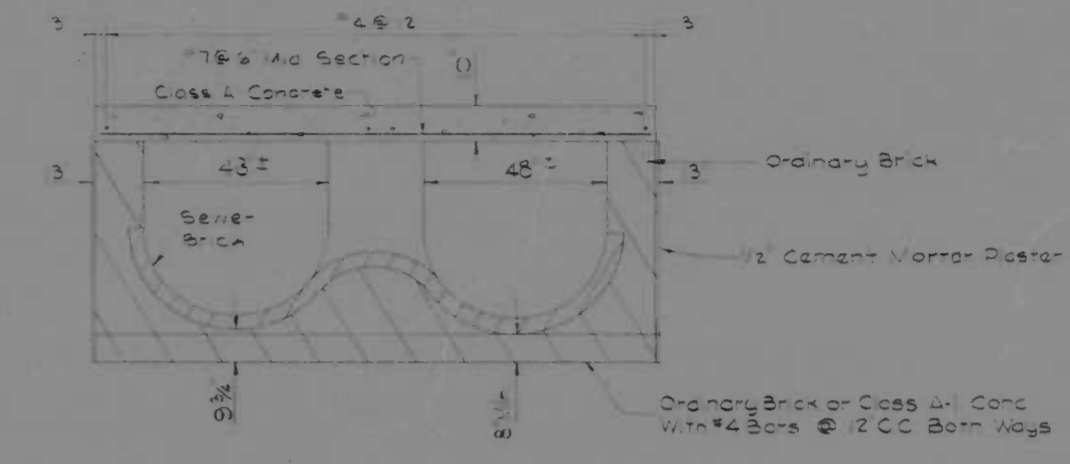

SECTION 'B'-'B'

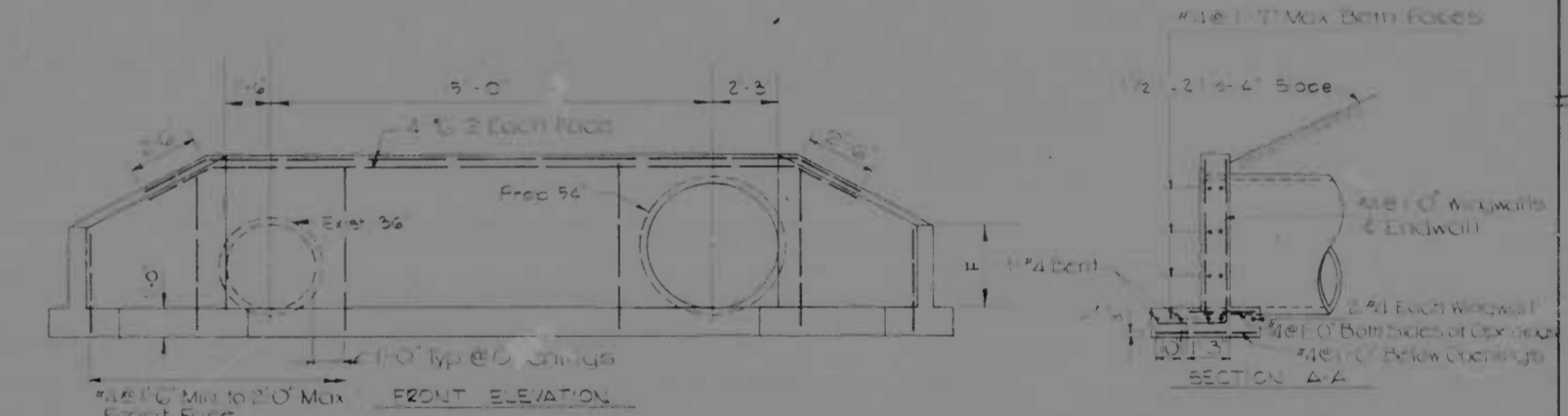

FRONT ELEVATION

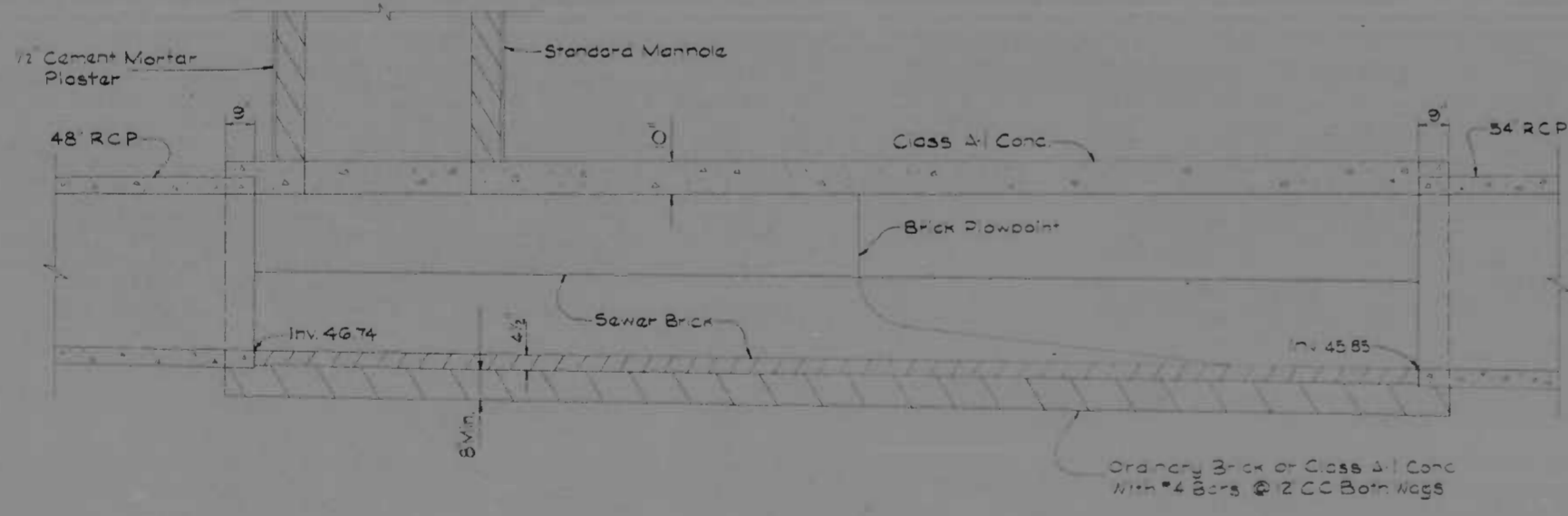

SECTION 'A'-'A'

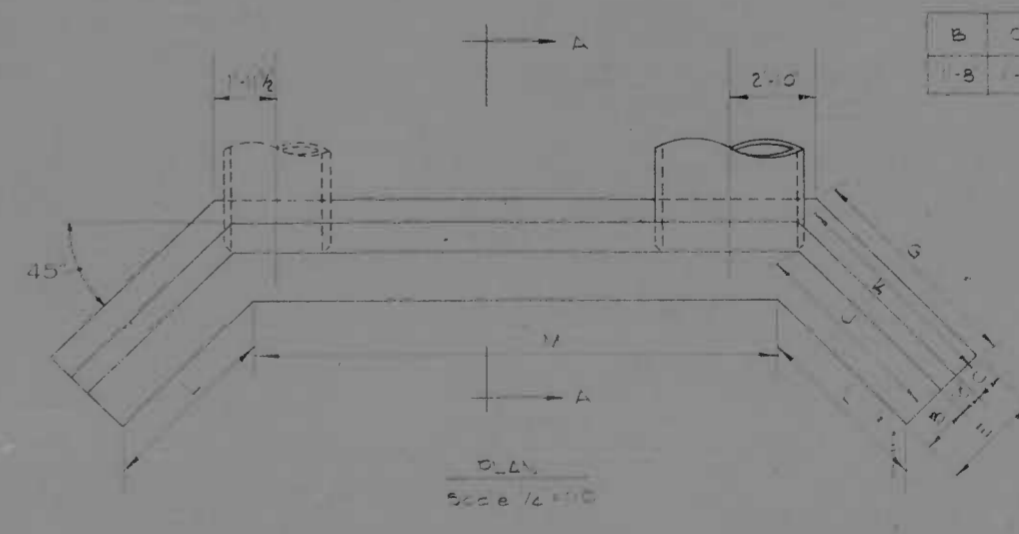

SPECIAL 'B' HEADWALL

B	C	E	F	G	H	K	L	M
1-B	1-C	3-B	3-C	1-B	1-C	1-D	1-E	1-F

REVISIONS	CONSULTANT	CITY OF BALTIMORE DEPARTMENT OF PUBLIC WORKS	STATE ROADS COMMISSION OF MARYLAND INTERSTATE DIVISION FOR BALTIMORE CITY
	KANDLER, BERGER, STONE & ASSOC., INC.	INTERSTATE ROUTE 95	DRAWN BY: W.F.F.
	MATE, CUMAS & ARNER, INC. CONSULTING ENGINEERS	EASTERN AVENUE INTERCHANGE	TRACED BY: J.F.M.
	BALTIMORE, MARYLAND 21202	SCALE: AS SHOWN	DATE: 4-20-70
			SHEET NO. 28 OF 113

NO.	DATE	BY	CHKD.	TOTAL SHEETS
2	MD	1-20-4132136	25	113

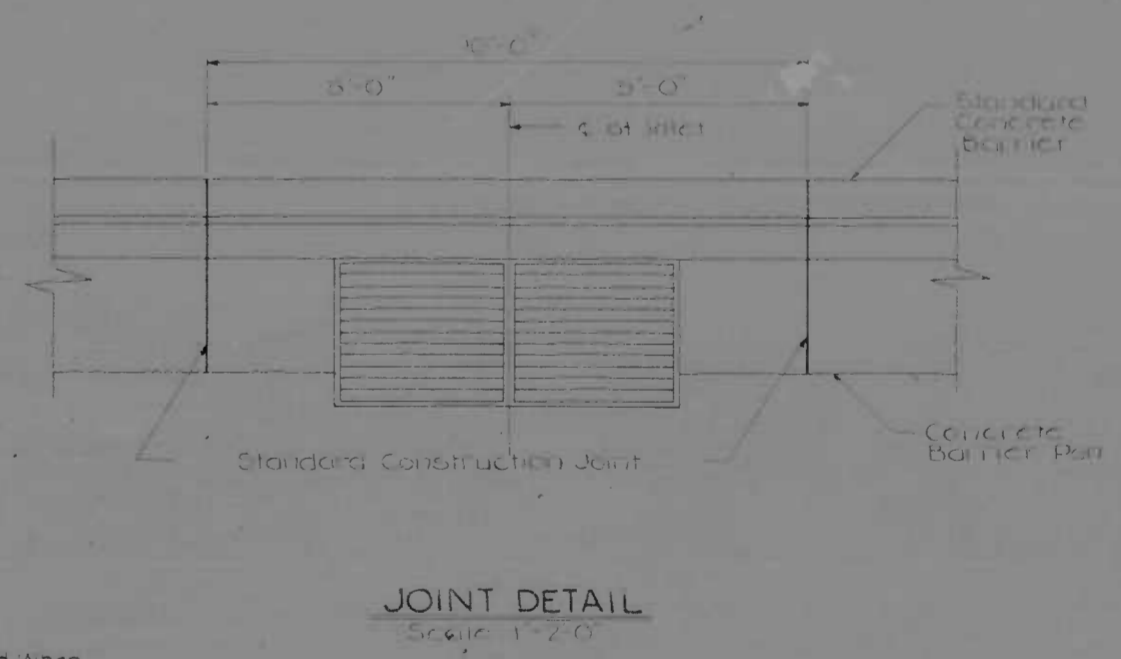
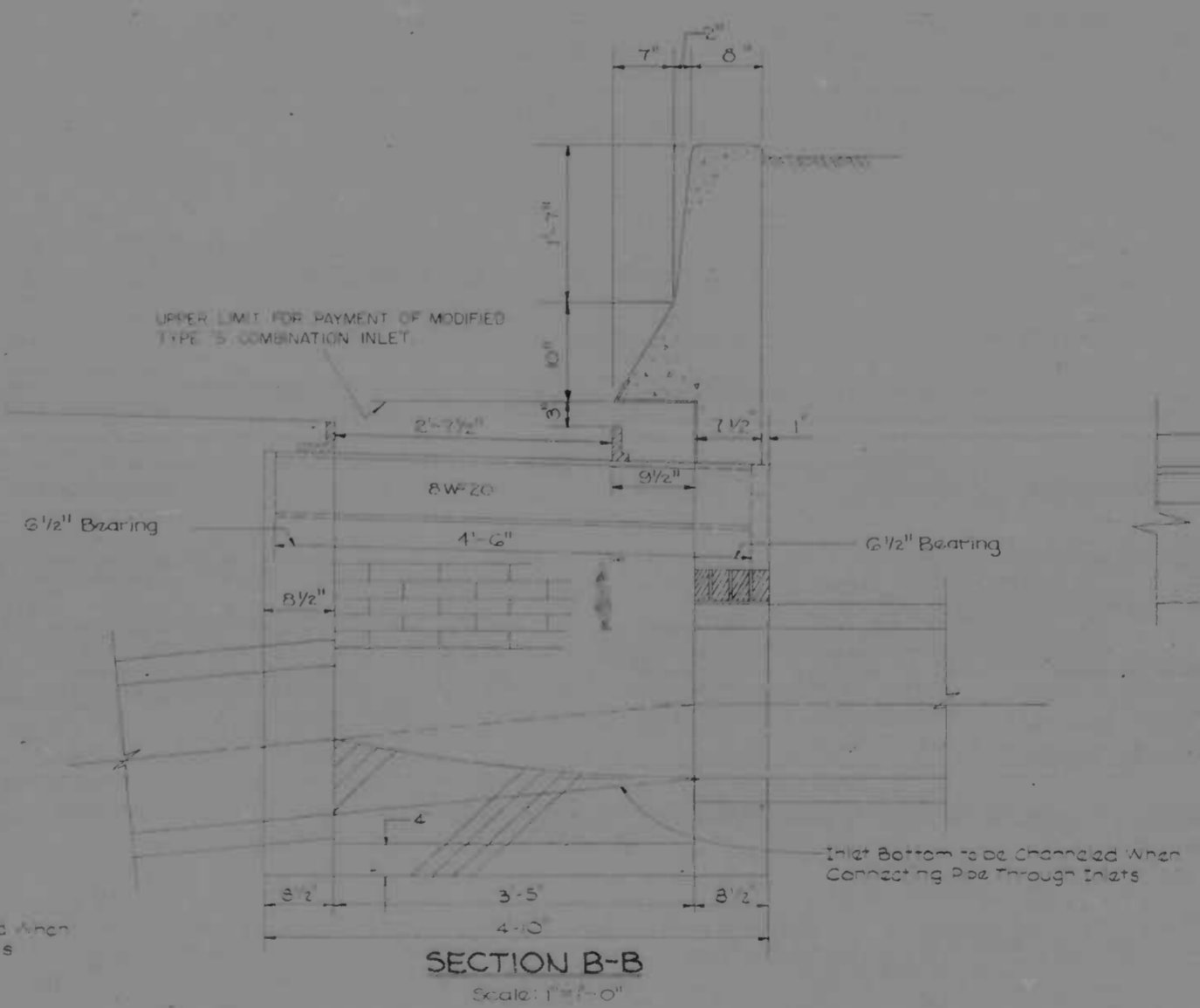
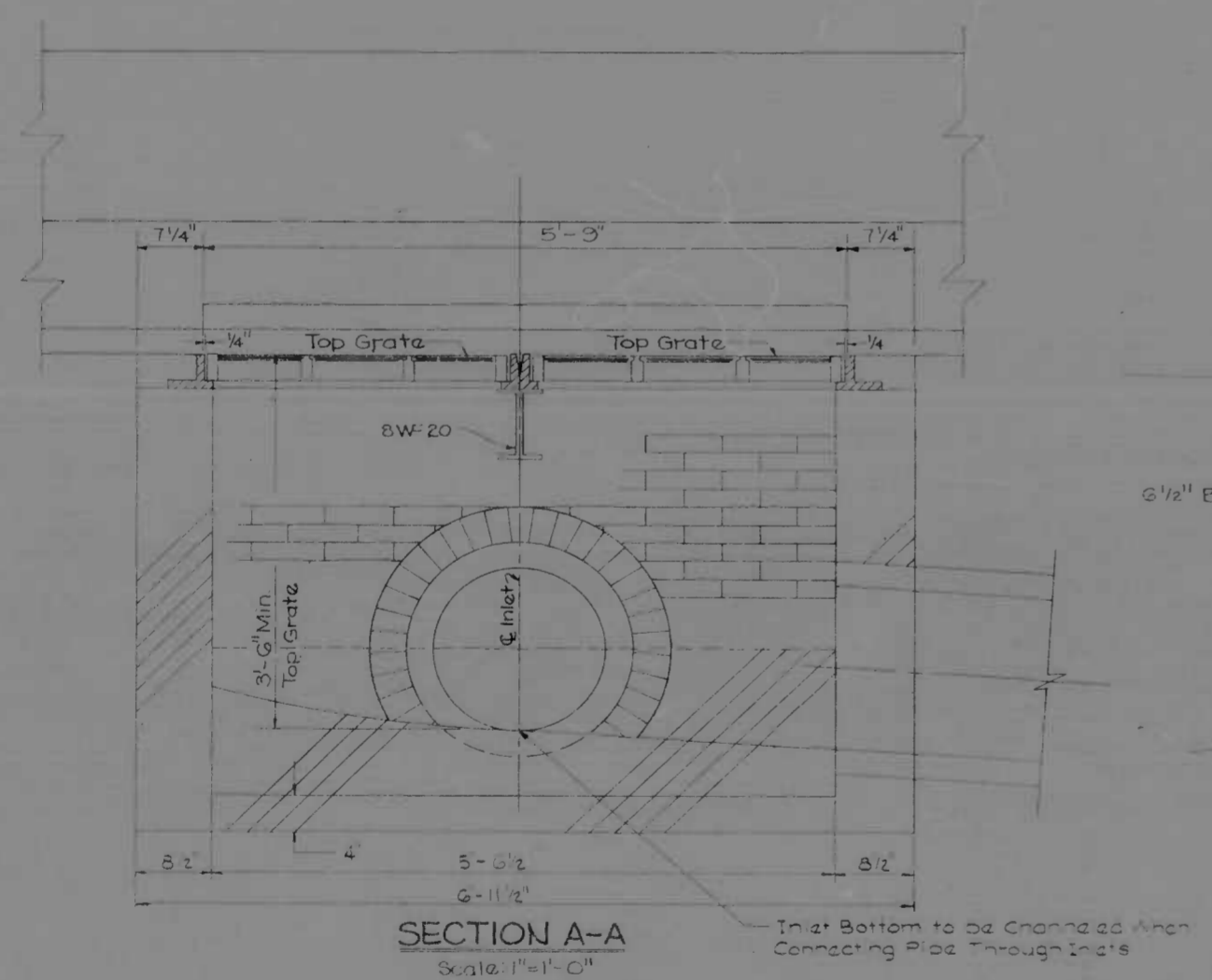
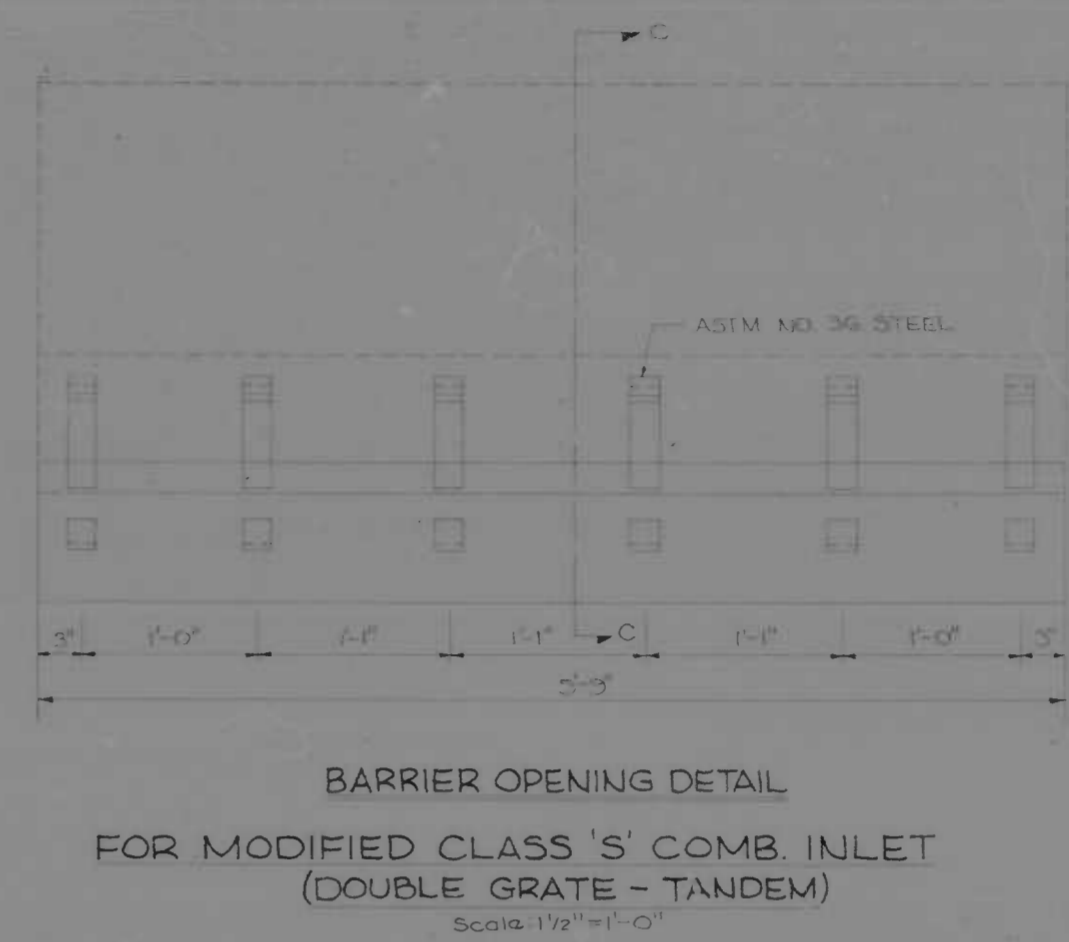
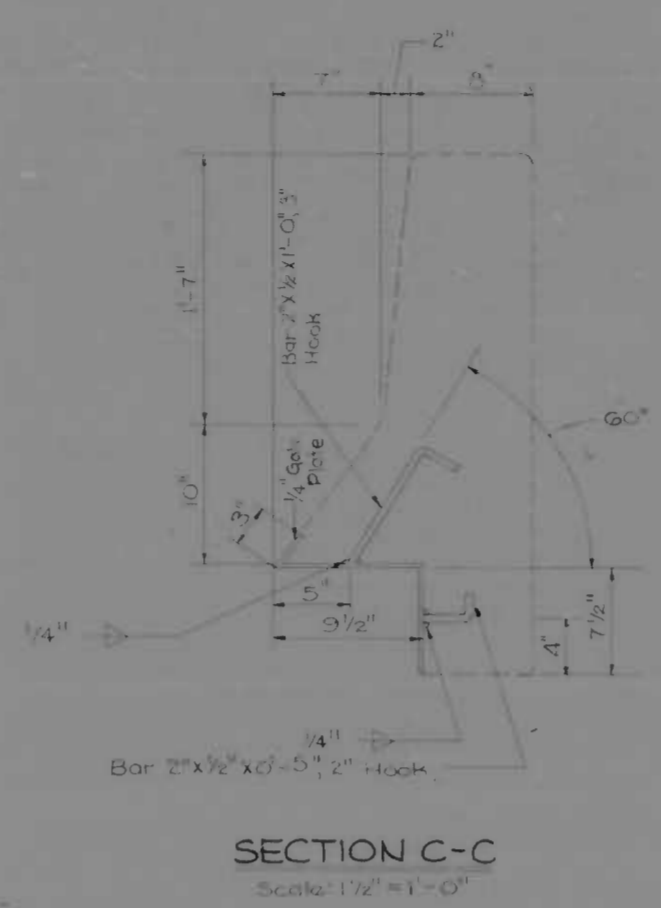
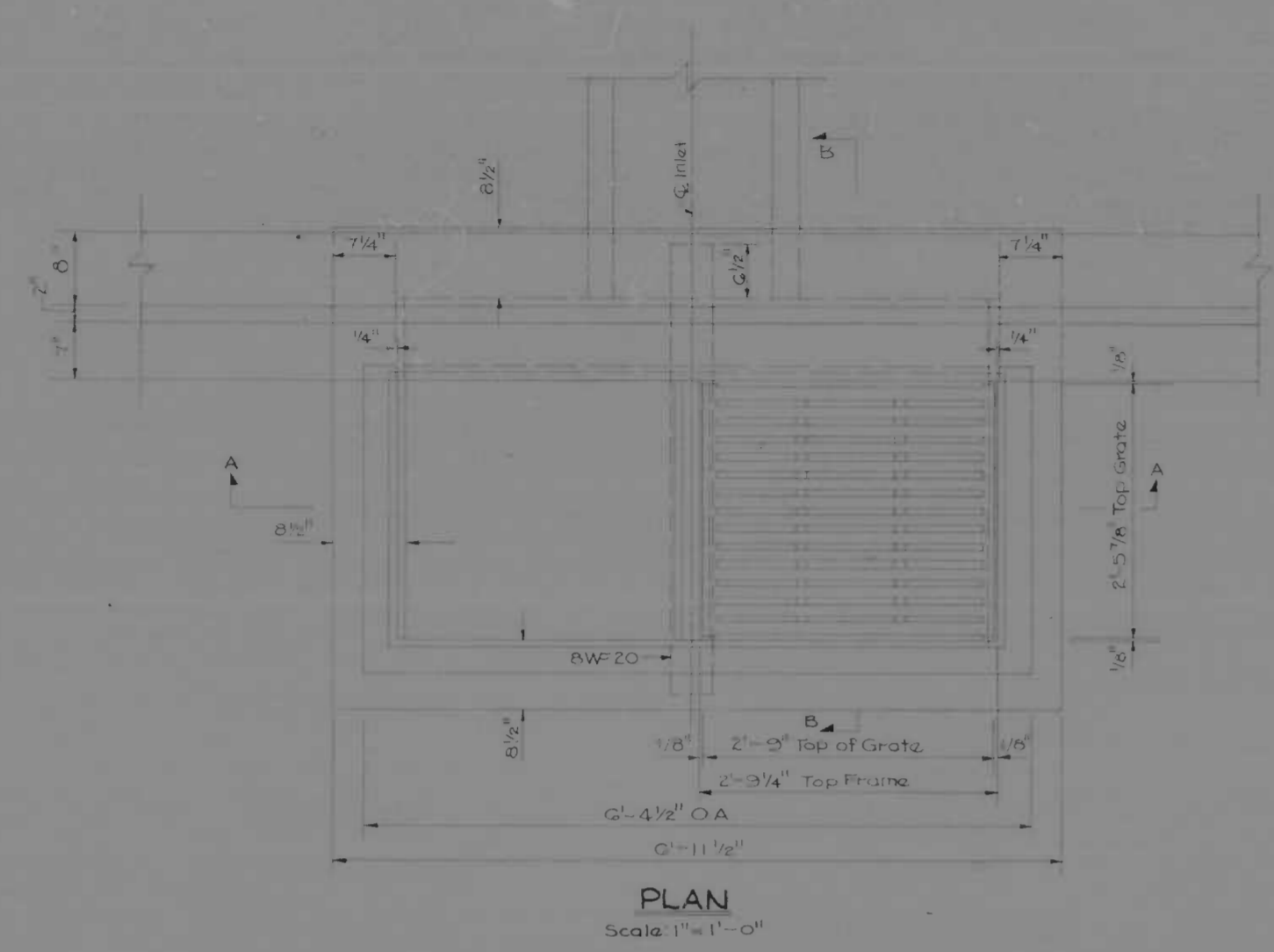

**MODIFIED CLASS 'S' COMBINATION
(DOUBLE GRATE-TANDEM)**

REVISIONS	CONSULTANT	CITY OF BALTIMORE DEPARTMENT OF PUBLIC WORKS	STATE ROADS COMMISSION OF MARYLAND INTERSTATE DIVISION FOR BALTIMORE CITY
	KNOWLE, BENDER, STONE & ASSOC., INC. 400 MATZ, CHIPS & ASSOC., INC. CONSULTING ENGINEERS 341 N. CALVERT STREET BALTIMORE, MARYLAND 21202	INTERSTATE ROUTE 95 EASTERN AVENUE INTERCHANGE	DRAWN BY: W.T.F. TRACED BY: J.E.M. F.A.P. NO. 95-4132136 S.R.C. NO. 100-246-24-813 BALTO. CITY NO. 1959
		SCALE: AS SHOWN	DATE: 4-20-70
			DES. BY: D.E.S. CHK. BY: J.W.H. SHEET NO. 29 of 113

NO.	DATE	BY	REVISIONS
2	MD, 1-95-4(32)36	3	113

INTERSTATE ROUTE 95

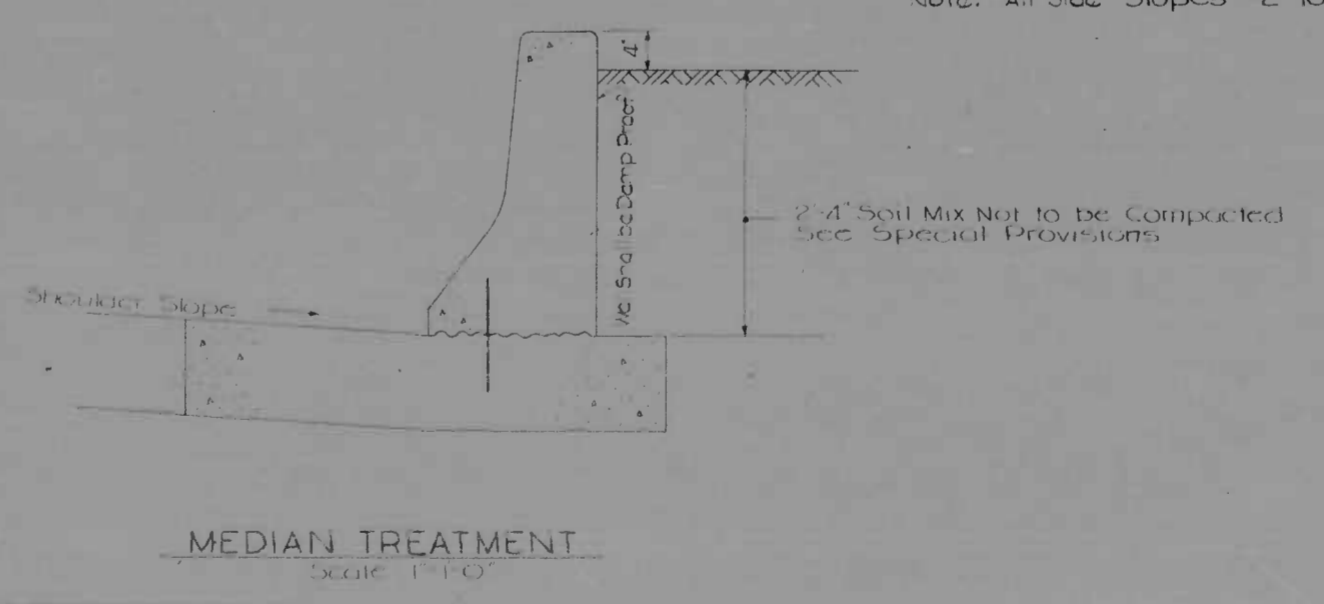
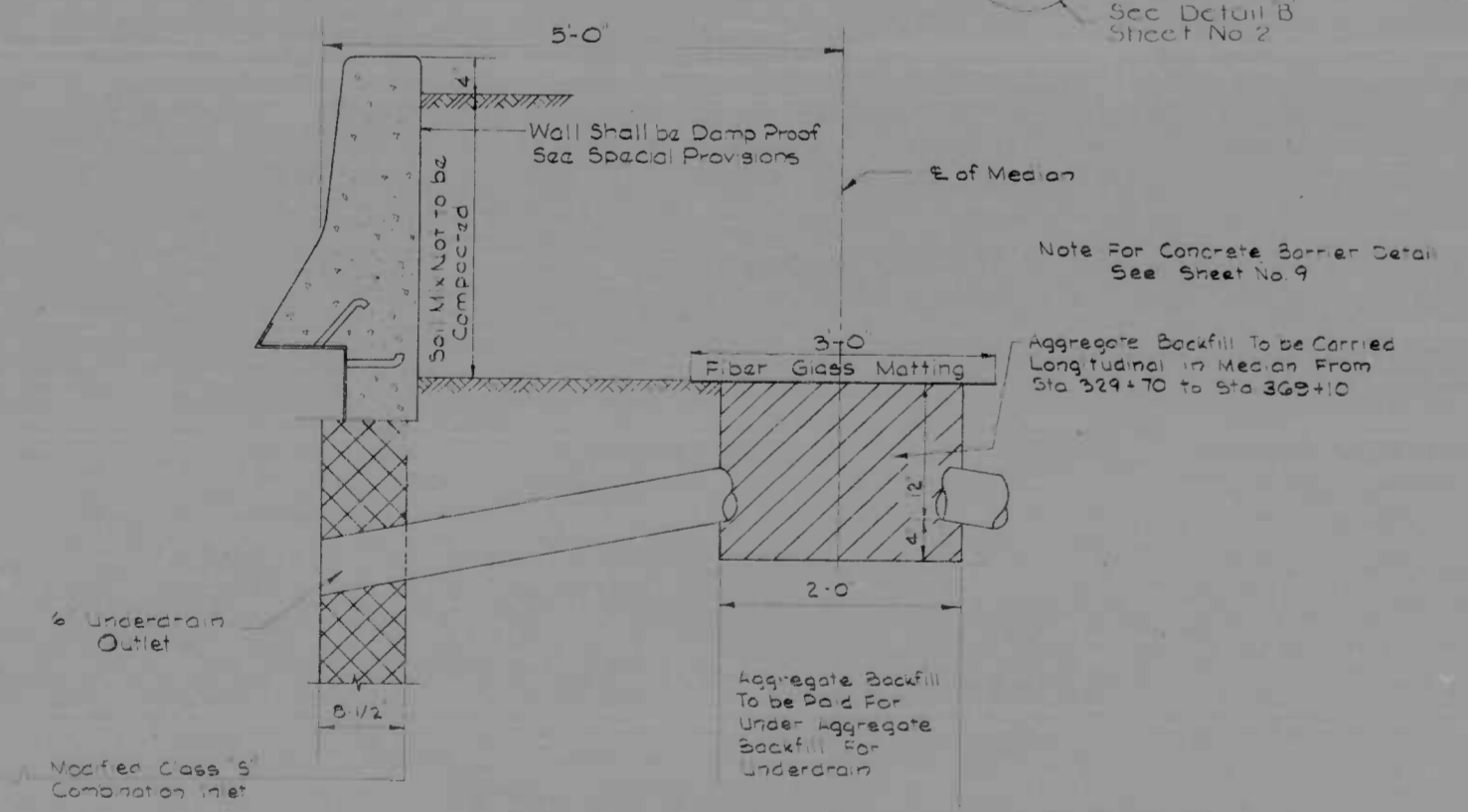
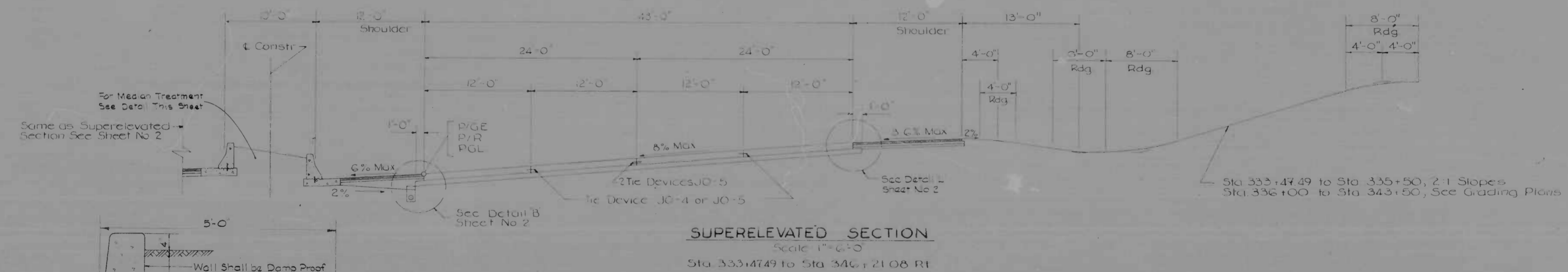
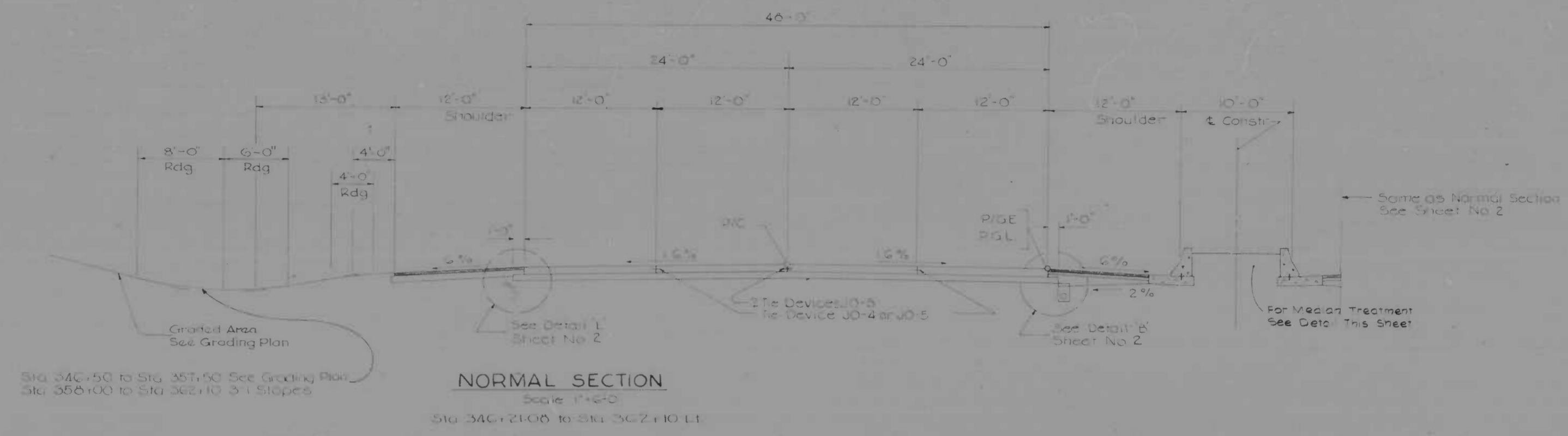

Note: All Side Slopes - 2" Topsoil, Seed and Mulch

REVISIONS	CONSULTANT	CITY OF BALTIMORE	STATE ROADS COMMISSION OF MARYLAND
	KHOEHL, BENDER, STONE & ASSOC., INC. AND MATZ, CHILDS & ASSOC., INC. CONSULTING ENGINEERS 341 N. CALVERT STREET BALTIMORE, MARYLAND 21202	DEPARTMENT OF PUBLIC WORKS	INTERSTATE DIVISION FOR BALTIMORE CITY
		INTERSTATE ROUTE 95	DRAWN BY: JJK
		EASTERN AVENUE INTERCHANGE	DES. BY: DES
			TRACED BY: JJK
			CHEK BY: SWH
			F.A.P. NO. 1-95-4(32)36
			S.R.C. NO. - BC 246-29-B15
			BALTA-CITY NO. 1959
		SCALE: AS SHOWN	DATE: 4-20-70
			SHEET NO. 3 OF 113

Sheet No.	2
MD	24-0000
AS	10



PAVEMENT LEGEND:

	Continuous Reinforced Cement Concrete
	Conventional Reinforced Cement Concrete
	Existing Pavement

GORE DETAIL RAMP 'A'

REVISIONS	CONSULTANT	CITY OF BALTIMORE DEPARTMENT OF PUBLIC WORKS	STATE ROADS COMMISSION OF MARYLAND INTERSTATE DIVISION FOR BALTIMORE CITY
	KROGER, BEMER, STONE & ASSOC., INC. MATT. CHADDS & ASSOC., INC. CONSULTING ENGINEERS 381 N. BRIDGE STREET BALTIMORE, MARYLAND 21202	INTERSTATE ROUTE 95 EASTERN AVENUE INTERCHANGE	DRAWN BY: W.F.P. CHECKED BY: J.M. DATE: 4-20-70
		SCALE: 1"=20'	DATE: 4-20-70



PAVEMENT LEGEND

	8" Continuous Reinforced Cement Concrete
	8" Conventional Reinforced Cement Concrete
	Composite Pavement

GORE DETAIL RAMP 'B'

REVISIONS	CONSULTANT	CITY OF BALTIMORE DEPARTMENT OF PUBLIC WORKS	STATE ROADS COMMISSION OF MARYLAND INTERSTATE DIVISION FOR BALTIMORE CITY
	KROEHL, RINDOR, STUM & ASSOC., INC. WATT, OFFICE & ASSOC., INC. CONSULTING ENGINEERS 341 N. CALVERT STREET BALTIMORE, MARYLAND 21202	INTERSTATE ROUTE 95 EASTERN AVENUE INTERCHANGE	DRAWN BY: RVE CHECKED BY: SWH DESIGNED BY: SWH DATE: 8-20-73 SHEET NO. 117-118
		SCALE: 1" = 20'	DATE: 8-20-73

DATE	BY
10/20/00	WJG
11/15/00	WJG
12/15/00	WJG



Note:
For Curve Data, See Sheet No. 10

PAVEMENT LEGEND

	5' Concrete Reinforced Cement Concrete
	3' Concrete Reinforced Cement Concrete
	Continuing Pavement

GORE DETAIL RAMP 'C'

REVISIONS	CONSULTANT	CITY OF BALTIMORE DEPARTMENT OF PUBLIC WORKS	STATE ROADS COMMISSION OF MARYLAND INTERSTATE DIVISION FOR BALTIMORE CITY
	GARRETT HENDERSON & ASSOC., INC. WHE CHRYSLER & ASSOC., INC. CONSULTING ENGINEERS BALTIMORE, MARYLAND	INTERSTATE ROUTE 83 EXIT 78B - I-95 INTERCHANGE	DRAWN BY: [] CHECKED BY: [] DATE: 8-20-00
		SCALE: []	DATE: 8-20-00

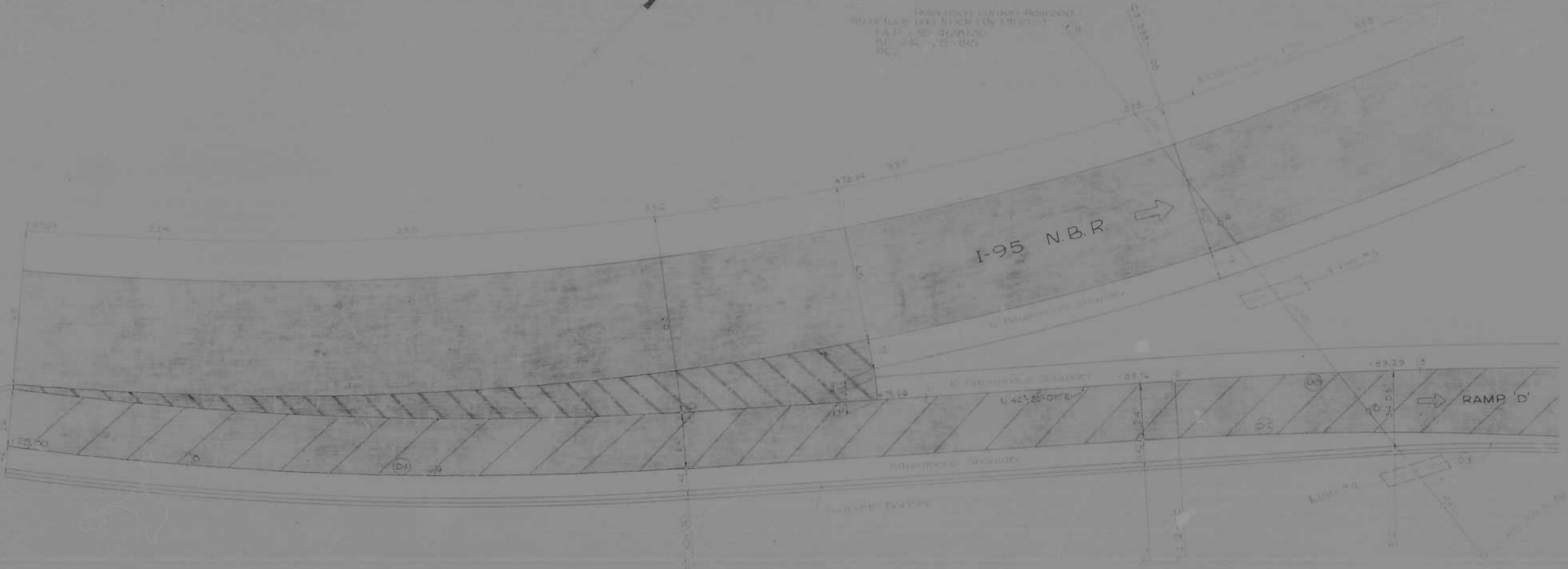

Refer to Curve Data - See Sheet No. 16

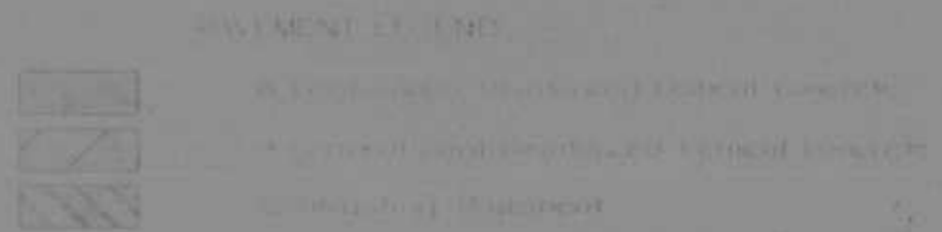

GORE DETAIL RAMP 'D'

REVISIONS	CONSULTANTS	CITY OF BALTIMORE DEPARTMENT OF PUBLIC WORKS	STATE ROADS COMMISSION OF MARYLAND INTERSTATE DIVISION FOR BALTIMORE CITY
	ENRICH ENGINEERING & ARCHITECTURE, INC. 1000 W. BALTIMORE AVENUE BALTIMORE, MD 21201	1000 W. BALTIMORE AVENUE BALTIMORE, MD 21201	1000 W. BALTIMORE AVENUE BALTIMORE, MD 21201

2	MD	100	400	4	3
---	----	-----	-----	---	---

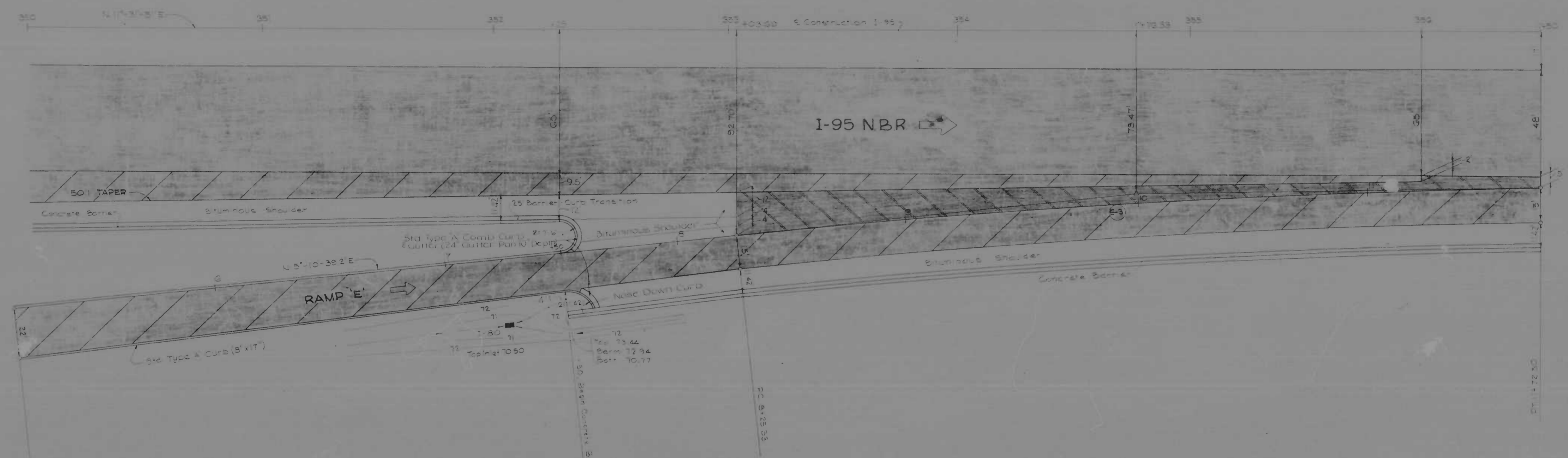

PAVEMENT LEGEND

- 5 Continuous Reinforced Cement Concrete
- 9 Concrete and Reinforced Cement Concrete
- Contrasting Pavement

Note: For Curve Data, See Sheet No. 16

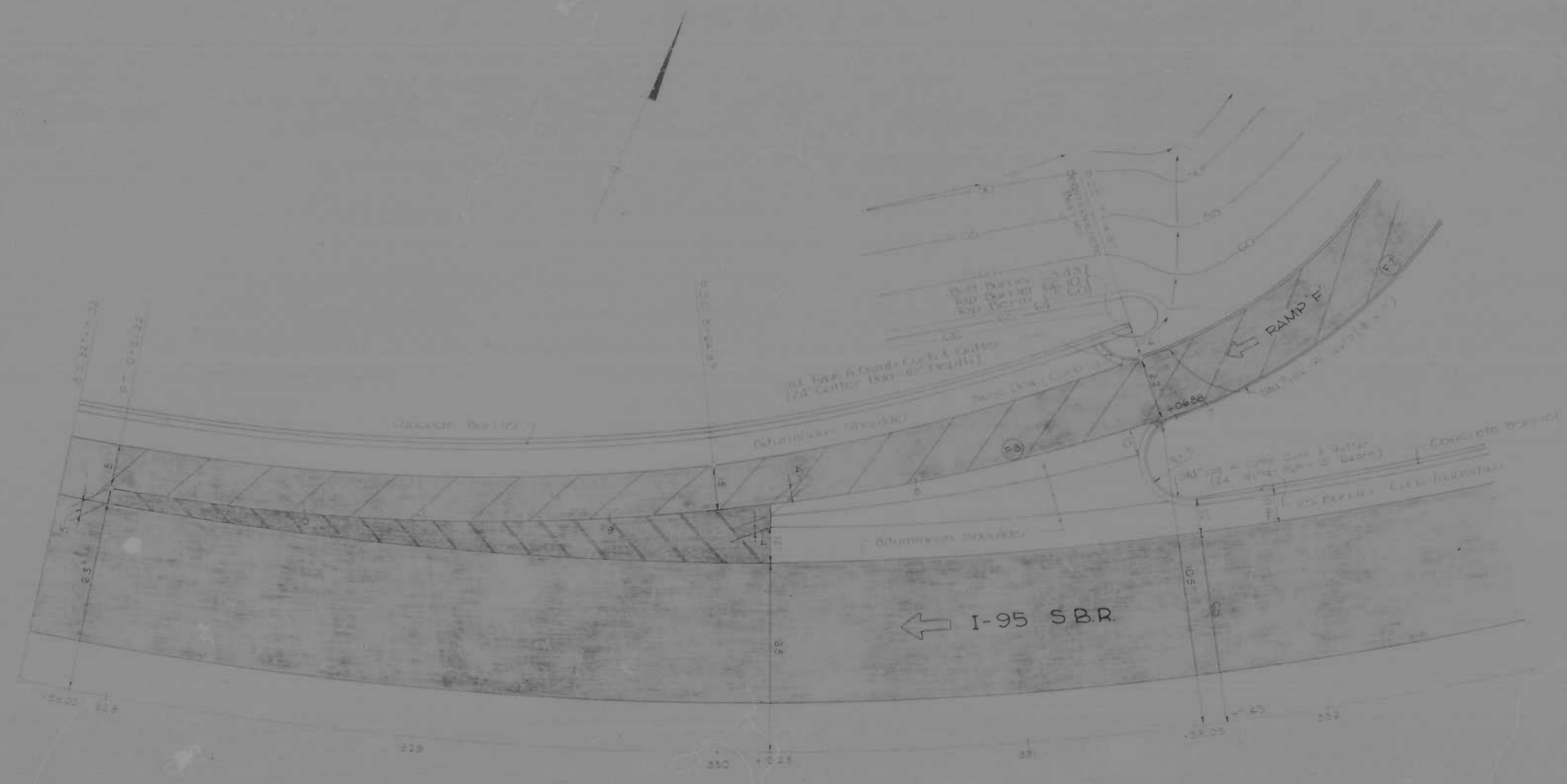

GORE DETAIL RAMP 'E'

REVISIONS	CONSULTANT	CITY OF BALTIMORE	STATE ROADS COMMISSION OF MARYLAND
	KIMBLE BENTON STINE & ASSOC., INC.	DEPARTMENT OF PUBLIC WORKS	INTERSTATE DIVISION FOR BALTIMORE CITY
	MAT. ENGINEERS & ARCHTS., INC. CONSULTING ENGINEERS 341 N. CALVERT STREET BALTIMORE, MARY. 21202	INTERSTATE ROUTE 95 EASTERN AVENUE INTERCHANGE	DRAWN BY: J.P.S. CHECKED BY: J.M.A. DATE: 4-10-70
		SCALE: 1" = 20'	DESIGNED BY: J.P.S. CHECKED BY: J.M.A. DATE: 4-10-70
			SHEET NO.: 34 OF 33



12014
See Curve Data, See Sheet 100-2

PAVEMENT LEGEND

-  1. Concrete Reinforced Cement Concrete
-  2. Concrete Reinforced Cement Concrete
-  3. Concrete Reinforced Cement Concrete

GORE DETAIL RAMP 'F'

REVISIONS	CONSULTANT	CITY OF BALTIMORE DEPARTMENT OF PUBLIC WORKS	STATE ROADS COMMISSION OF MARYLAND INTERSTATE DIVISION FOR BALTIMORE CITY
	<p>KOPELL, BAKER, STON & ASSOC., INC. 14720 WOODBURN RD. BALTIMORE, MD 21244</p>	<p>STATE STS. DIV. 1000 W. BALTIMORE ST. BALTIMORE, MD 21201</p>	<p>STATE STS. DIV. 1000 W. BALTIMORE ST. BALTIMORE, MD 21201</p>

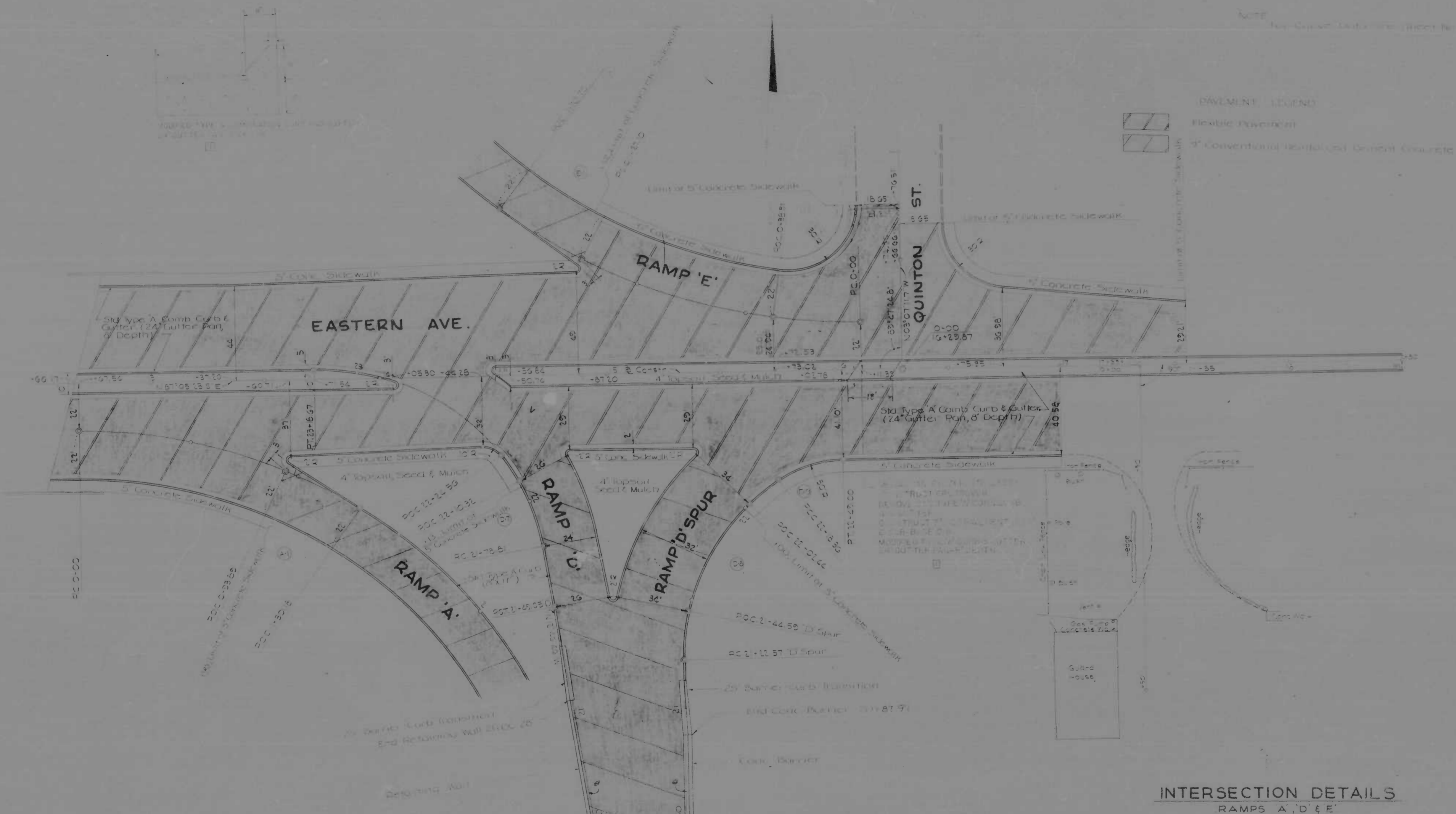

REVISIONS 1. 11/15/56 2. 11/15/56	CONSULTANT KIMBLE, BURNETT, STONE & ASSOC., INC. 141 N. CALVERT STREET BALTIMORE, MD. 21202	CITY OF BALTIMORE DEPARTMENT OF PUBLIC WORKS		STATE ROADS COMMISSION OF MARYLAND INTERSTATE DIVISION FOR BALTIMORE CITY	
		INTERSTATE ROUTE 83 EASTERN AVENUE INTERCHANGE		DRAWN BY: RFD CHECKED BY: RFD	DESIGNED BY: RFD CHECKED BY: RFD

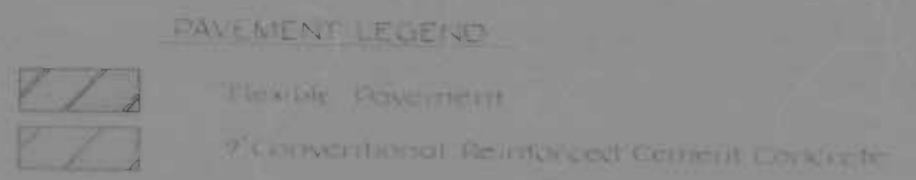

Note: For Curve Data, See Sheet No. 16

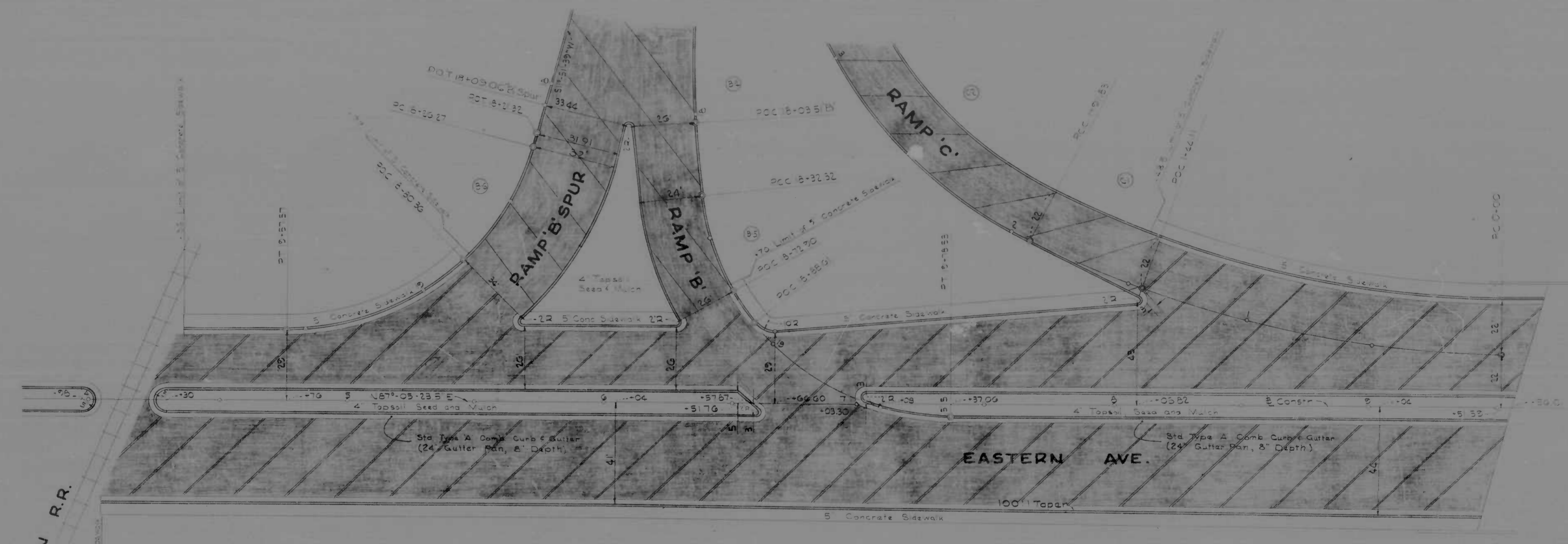

CANTON R.R.

INTERSECTION DETAILS
RAMPS 'B' & 'C'

REVISIONS	CONSULTANT	CITY OF BALTIMORE DEPARTMENT OF PUBLIC WORKS	STATE ROADS COMMISSION OF MARYLAND INTERSTATE DIVISION FOR BALTIMORE CITY
	KINDERLE, BEMER, STONE & ASSOC., INC. MATZ, CHURCH & ASSOC., INC. CONSULTING ENGINEERS 381 N. CALVERT STREET BALTIMORE, MARYLAND 21202	INTERSTATE ROUTE 83 EASTERN AVENUE INTERCHANGE	DRAWN BY: RFD CHECKED BY: RFD DATE: 1-10-70 SHEET NO. 17
		SCALE: 1"=20'	DATE: 1-10-70

PROJECT NO.	DATE	SCALE	SHEET NO.	TOTAL SHEETS
2	MD. 1-95-413256	38	113	

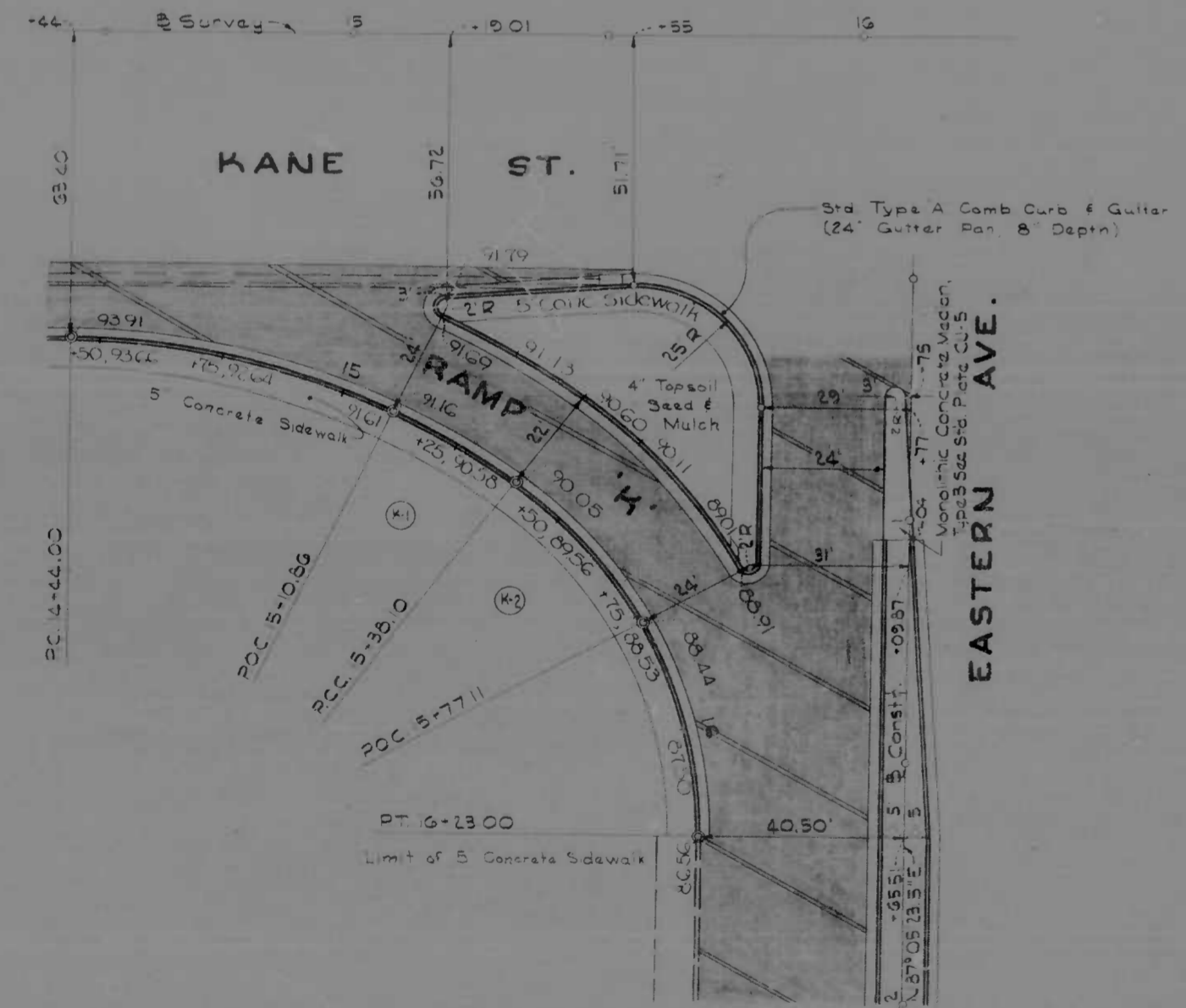
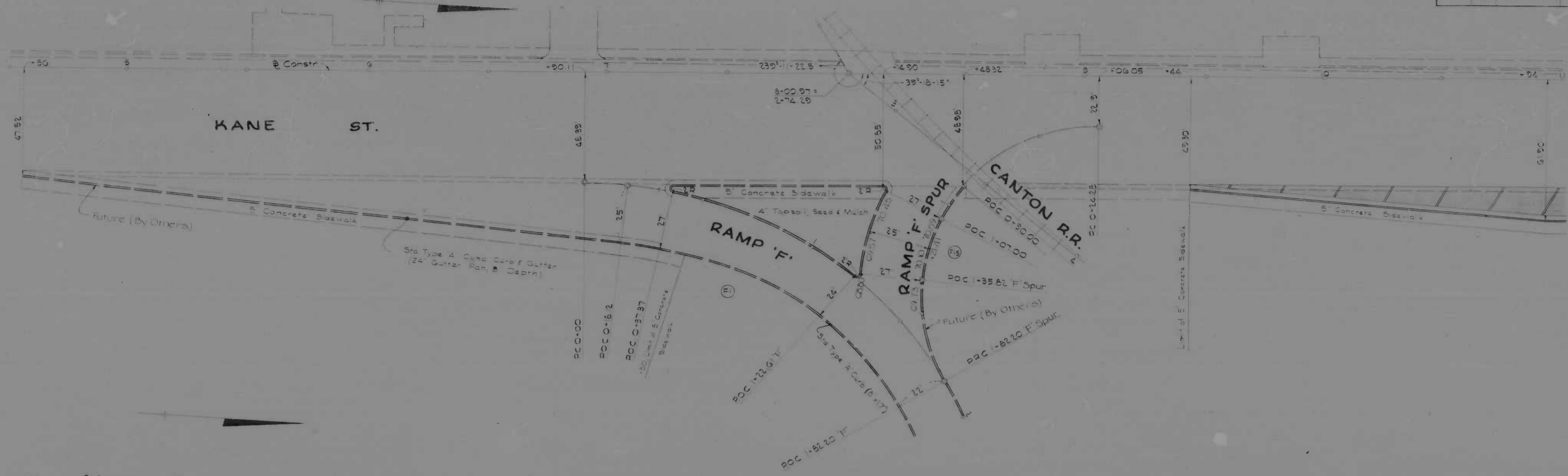

NOTE: For Curve Data, See Sheet No. 13

PAVEMENT LEGEND

	Flexible Pavement
	Conventional Reinforced Cement Concrete

INTERSECTION DETAILS
RAMPS 'K' & 'F'

REVISIONS	CONSULTANT	CITY OF BALTIMORE DEPARTMENT OF PUBLIC WORKS	STATE ROADS COMMISSION OF MARYLAND INTERSTATE DIVISION FOR BALTIMORE CITY
	AND MATZ, CHILDS & ASSOC., INC. CONSULTING ENGINEERS 342 N. CALVERT STREET BALTIMORE, MARYLAND 21202	& INTERSTATE ROUTE 95 EASTERN AVENUE INTERCHANGE	DRAWN BY: RFD TRACED BY: RFD F.P. NO. 1-95-413256 S.R.C. NO. RC 246-24-B15 BALTO. CITY NO. 950
		SCALE: 1"=20'	DATE: 4-20-70
			SHEET NO. 38 of 113

NO.	DATE	BY	REVISION
2	MD	1-95-4132/36	39 1/3

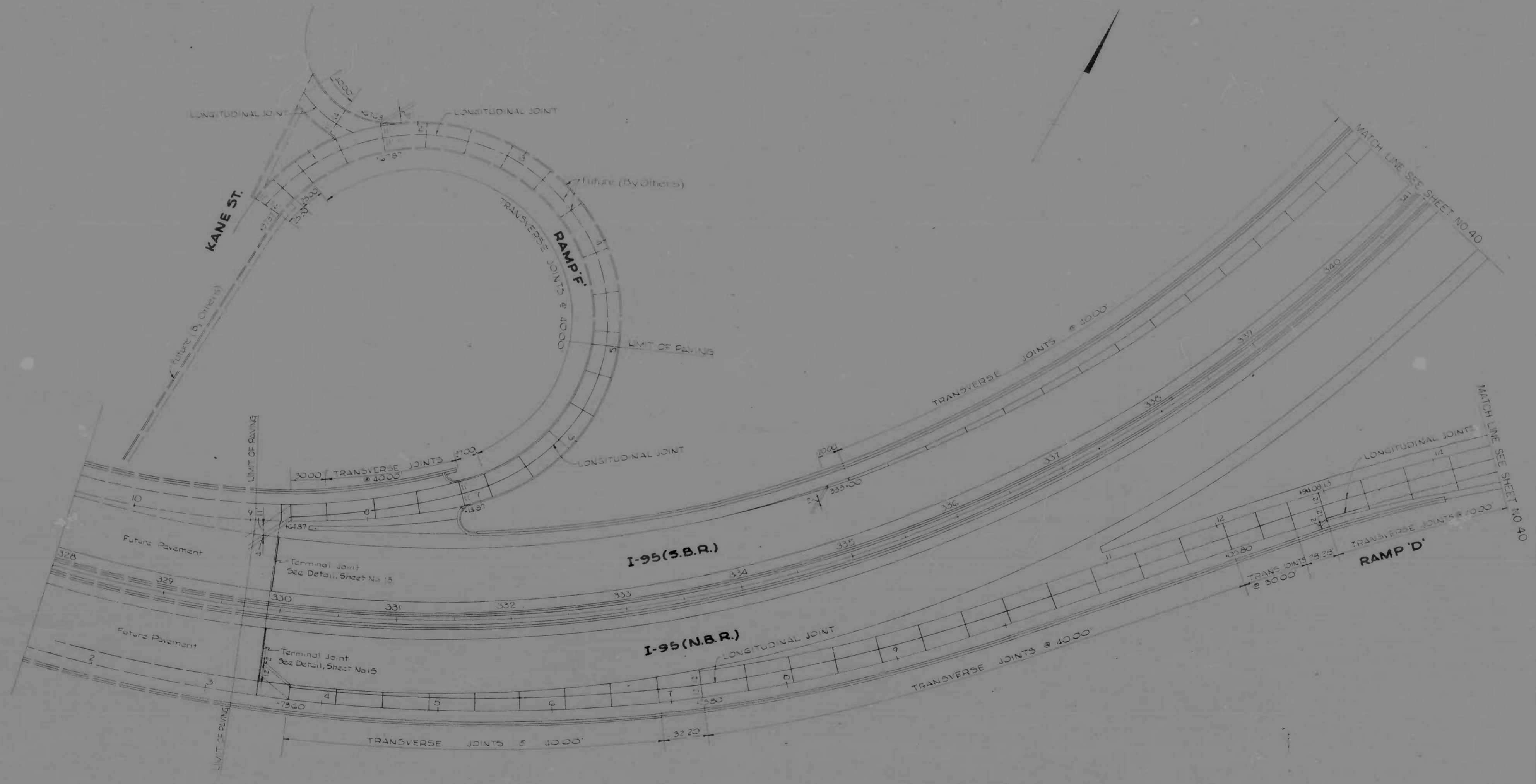

JOINT LAYOUT

REVISIONS	CONSULTANT	CITY OF BALTIMORE DEPARTMENT OF PUBLIC WORKS	STATE ROADS COMMISSION OF MARYLAND INTERSTATE DIVISION FOR BALTIMORE CITY
	KWIERLE, BENDER, STONE & ASSOC., INC. MATZ, CHILDS & ASSOC., INC. CONSULTING ENGINEERS 381 N. CALVERT STREET BALTIMORE, MARYLAND 21202	INTERSTATE ROUTE 95 EASTERN AVENUE INTERCHANGE	DRAWN BY: JJK TRACED BY: JJK F.A.P. NO. 1-95-4132/36 S.R.C. NO. BC 246-29-85 BALTO. CITY NO. 1959
		SCALE: 1"=40'	DATE: 4-20-70
			DES. BY: SWH CHK. BY: D.E.S. SHEET NO. 39 OF 113

FED. ROAD DIST. NO.	STATION	DATE	SHEET NO.	TOTAL SHEETS
2	MD. 1-95-11321-50		4	13

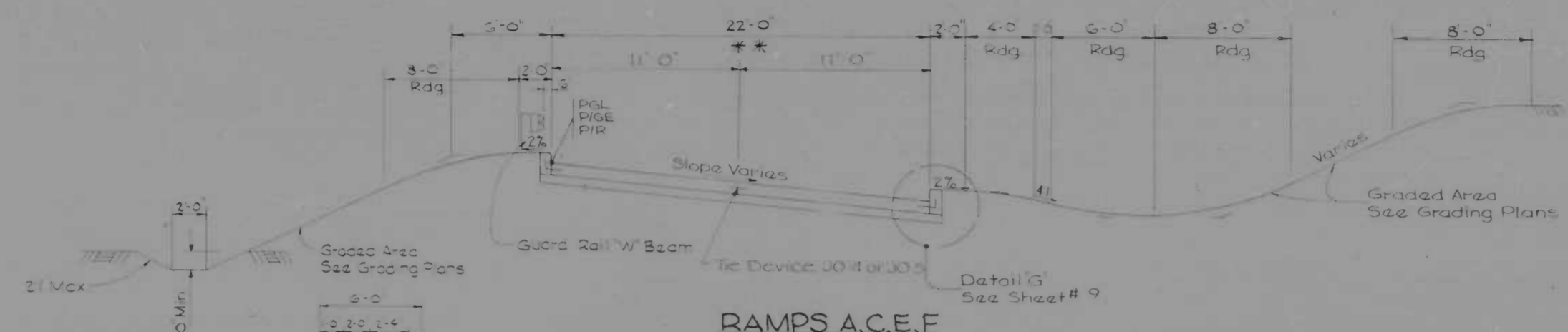

RAMPS A, C, E, F
Scale 1" = 5'-0"

Sta 11+30.18 to Sta 8+95.00 A
 Sta 11+91.03 to Sta 9+74.51 C
 Sta 11+40.75 to Sta 5+13.53 E
 Sta 5+00 to Sta 7+11.00 F
 * * * Sta 3+35.3 to Sta 7+20.00 E Varies 11.0 to 16.44

Retaining Wall
 1/2 Precast Expansion Joint
5" CONCRETE GUTTER
 Sta 3+00 to Sta 5+4.88 A

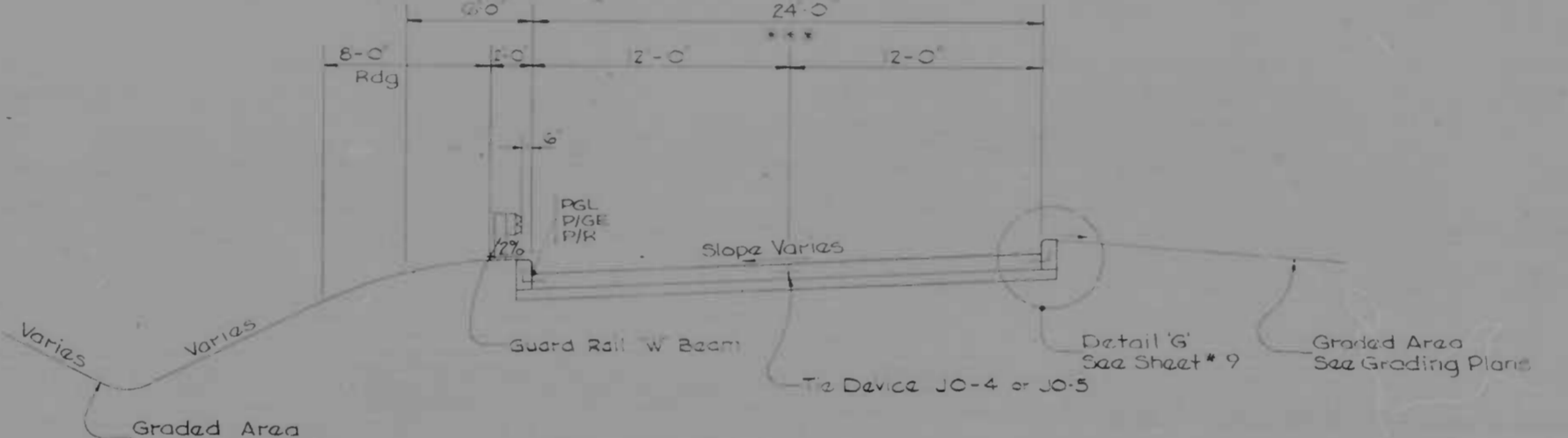

RAMPS D & B
Scale 1" = 5'-0"

Sta 21+49.05 to Sta 22+10.30 D
 Sta 10+03.51 to Sta 10+12.90 B
 * * * Sta 8+06.24 to Sta 10+01.13 B Varies 3.44 to 36.0

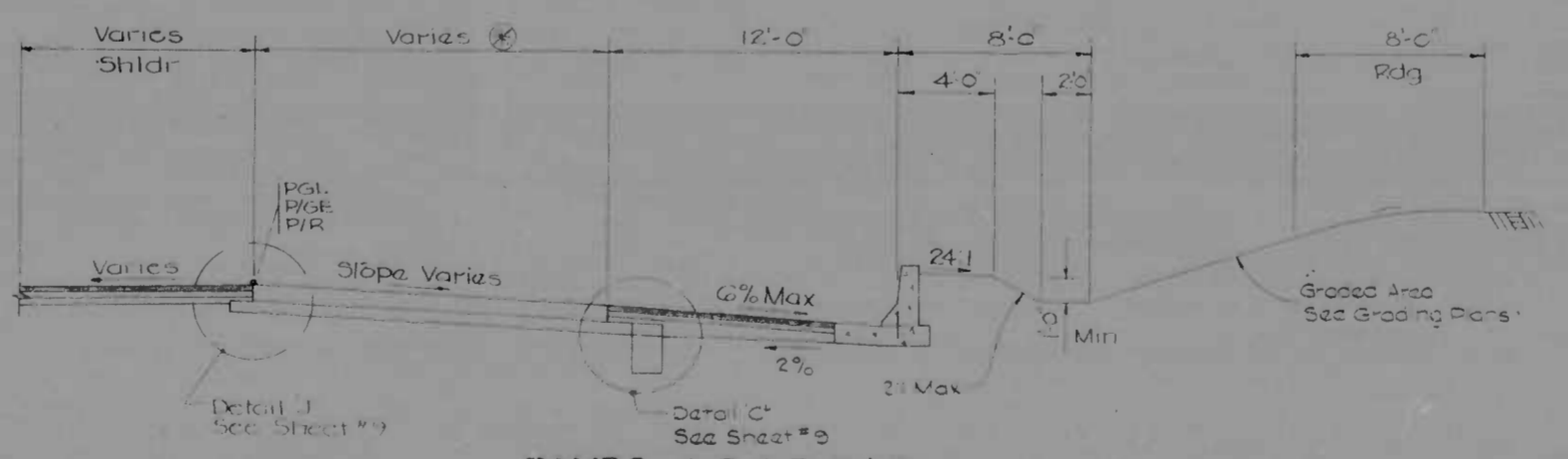

RAMPS A, B, C, D, E & F
Scale 1" = 5'-0"

* Sta 0+24.56 to Sta 6+26.21 B Varies 15.0 to 16.72
 Sta 9+09.48 to Sta 12+16.60 A Varies 22.0 to 15.0
 Sta 9+52.56 to Sta 13+35.93 C Varies 22.0 to 15.0
 Sta 7+50.00 to Sta 11+72.50 E Varies 16.44 to 15.0
 Sta 7+14.87 to Sta 10+61.22 F Varies 22.0 to 15.0
 Sta 7+25.80 to Sta 11+85.76 D 24.0

Note
 All Side Slopes - 2' Topsoil, Seed and Muck

REVISIONS	CONSULTANT	CITY OF BALTIMORE DEPARTMENT OF PUBLIC WORKS	STATE ROADS COMMISSION OF MARYLAND INTERSTATE DIVISION FOR BALTIMORE CITY
	KNOXLE, BENDER, STONE & ASSOC., INC. WATZ, CHILDS & ASSOC., INC. CONSULTING ENGINEERS 341 N. CALVERT STREET BALTIMORE, MARYLAND 21202	INTERSTATE ROUTE 95 EASTERN AVENUE INTERCHANGE	DRAWN BY: WFF TRACED BY: JDM DES. BY: DES CHK. BY: GWH F.A.P. NO. 1-95-11321-36 S.R.C. NO. 15-210-29-815 BALTO. CITY NO. 1959
		SCALE: AS SHOWN DATE: 4-20-70	SHEET NO. 4 of 13

NO.	DATE	BY	REVISION
2	MD 1-95-4122136	40	118

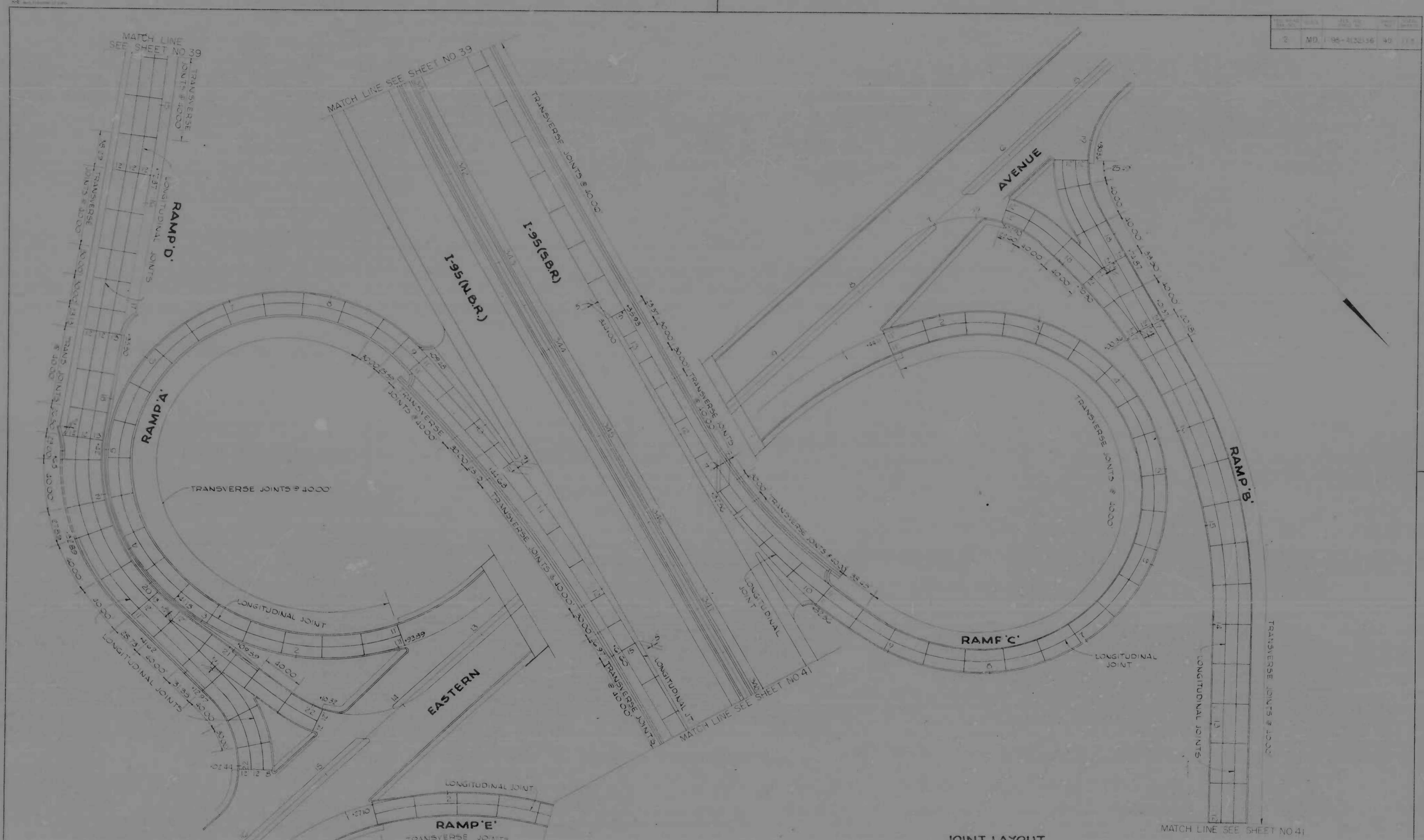

REVISIONS	CONSULTANT	CITY OF BALTIMORE DEPARTMENT OF PUBLIC WORKS	STATE ROADS COMMISSION OF MARYLAND INTERSTATE DIVISION FOR BALTIMORE CITY
	KROENKE, BENTLEY, STONE & ASSOC., INC. MATT, CHILDS & ASSOC., INC. CONSULTING ENGINEERS 341 N. CALVERT STREET BALTIMORE, MARYLAND 21202	INTERSTATE ROUTE 95 EASTERN AVENUE INTERCHANGE	DRAWN BY: JJK TRACED BY: JJK F.A.P. NO. 1-95-4122136 S.R.C. NO. BC 246-39-B15 BALTO. CITY NO. 1905
		SCALE: 1"=40'	DATE: 4-20-70
			PER. BY: S.W.H. CHK. BY: D.E.S.
			SHEET NO. 40 OF 118

NO.	MD	1-95-4(32)36	SHEET NO.	41	TOTAL SHEETS	113
-----	----	--------------	-----------	----	--------------	-----

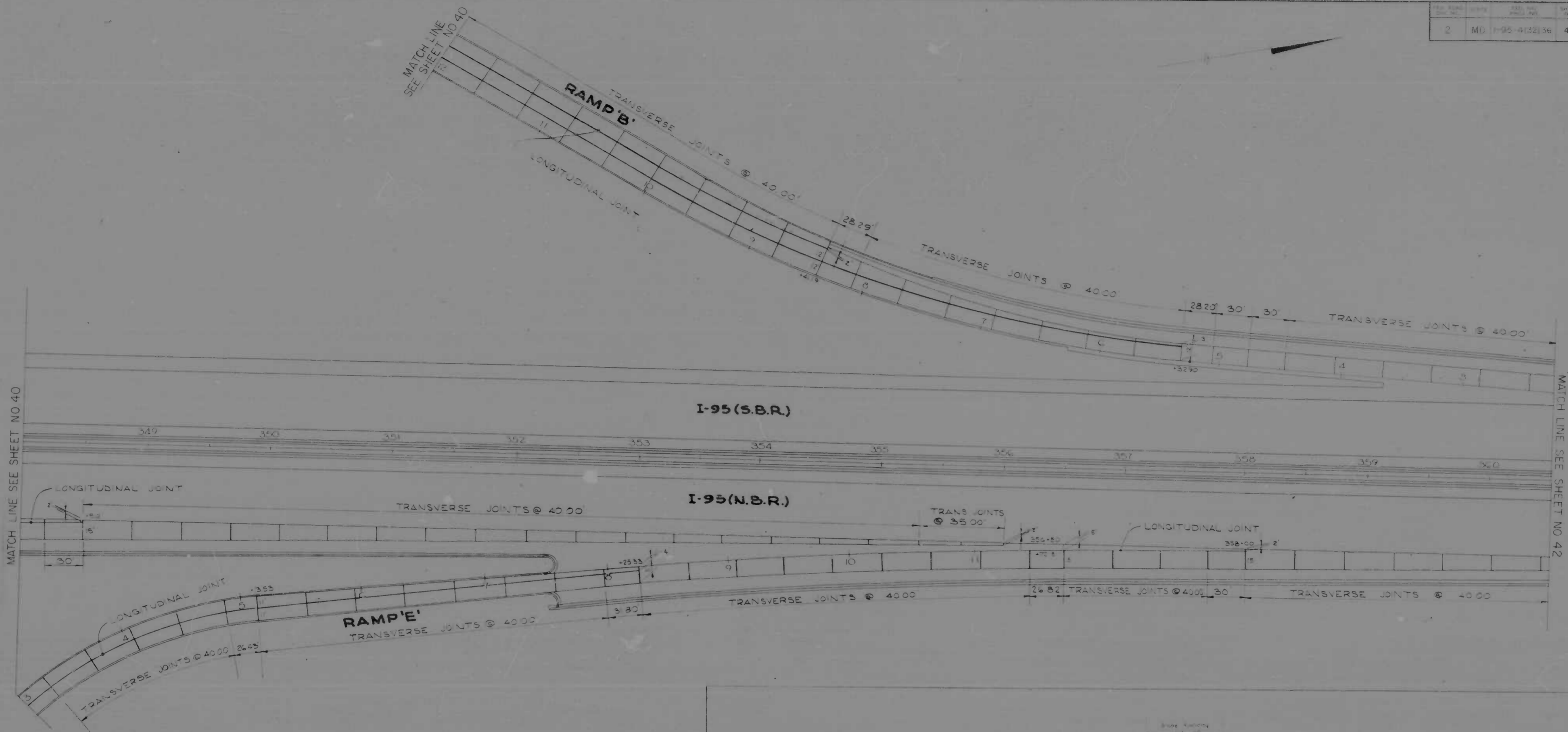

TYPICAL SECTIONS
 LANDSCAPING, BEAUTIFICATION, AND SAFETY SCREENING FOR EASTWOOD PARK

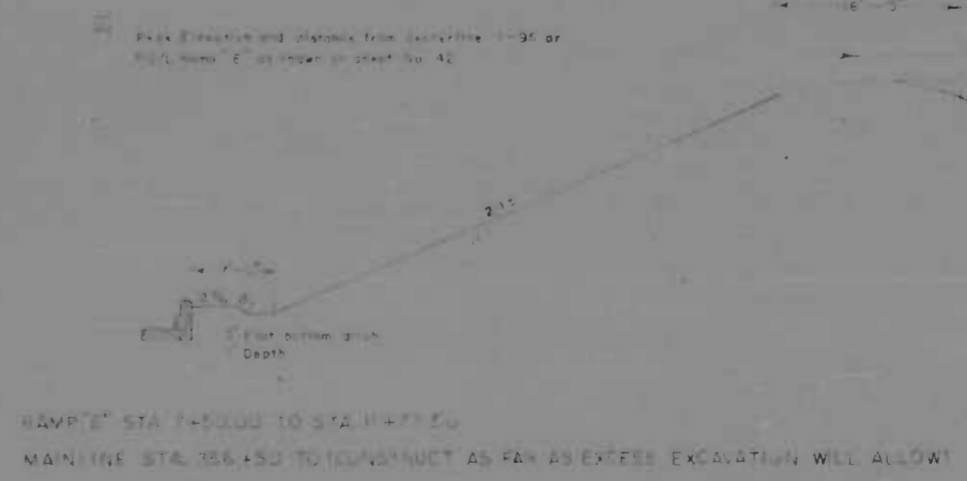
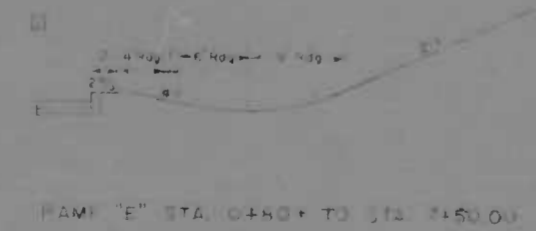

JOINT LAYOUT & LANDSCAPING DETAILS

REVISIONS	CONSULTANT	CITY OF BALTIMORE DEPARTMENT OF PUBLIC WORKS	STATE ROADS COMMISSION OF MARYLAND INTERSTATE DIVISION FOR BALTIMORE CITY
	KNORRE, BENDER, STONE & ASSOC., INC. 1400 HATZ, CHILDS & ASSOC., INC. CONSULTING ENGINEERS 541 N. LINCOLN STREET BALTIMORE, MARYLAND 21202	INTERSTATE ROUTE 95 EASTERN AVENUE INTERCHANGE	DRAWN BY: JJK TRACED BY: JJK F.A.P. NO. 1-95-4(32)36 S.R.C. NO. BC 246-29-615 BALTO. CITY NO. 1959
		SCALE: 1" = 40' X 1" = 40'	DATE: 4-20-70
			DES. BY: S.W.H. CHK. BY: P.F.S. SHEET NO. 41 OF 113

STATE	PROJECT NO.	SHEET NO.	TOTAL SHEETS
MD	1-95-432136	42	118

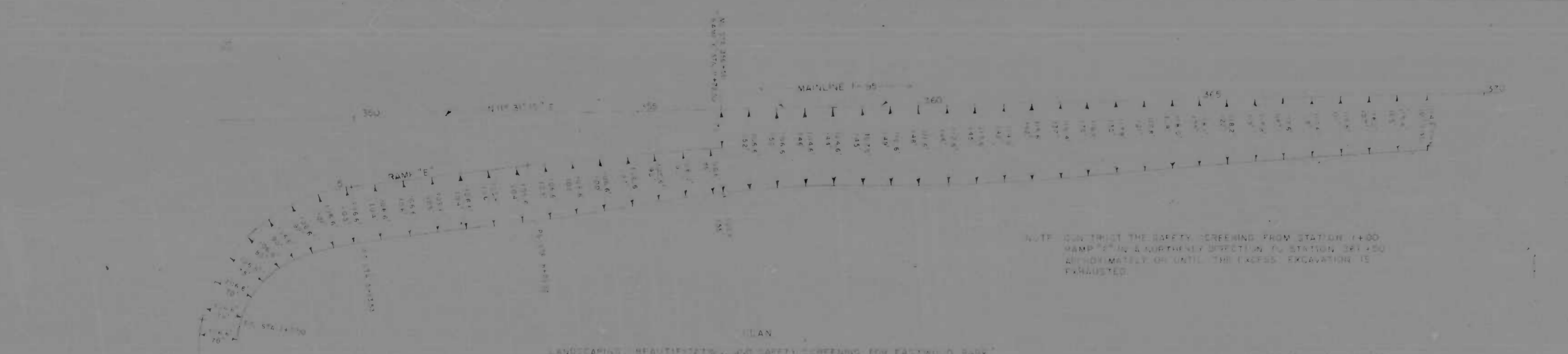
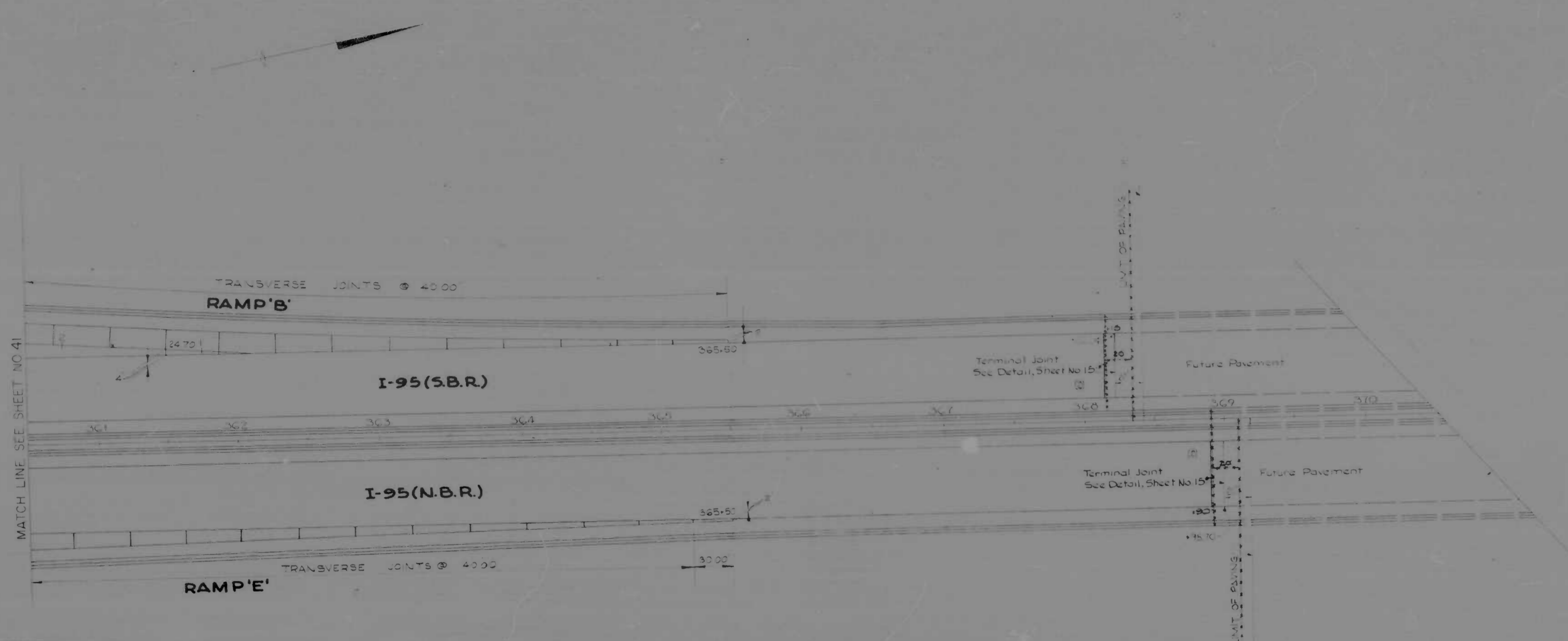

JOINT LAYOUT (LANDSCAPING) DETAILS

REVISIONS 1. (See Cover or Page 4 of 7)	CONSULTANT KNOERLE, BENDER, STONE & ASSOC., INC. AND MATZ, CHRIS & ASSOC., INC. CONSULTING ENGINEERS 545 N. EASTER STREET BALTIMORE, MARYLAND 21202	CITY OF BALTIMORE DEPARTMENT OF PUBLIC WORKS	STATE ROADS COMMISSION OF MARYLAND INTERSTATE DIVISION FOR BALTIMORE CITY
		INTERSTATE ROUTE 95 EASTERN AVENUE INTERCHANGE	DRAWN BY: JJK CHECKED BY: JJK F.A.P. NO. 1-95-432136 S.C. NO. DC 208-59-85 BALTO. CITY NO. 559
SCALE: 1" = 40' ± DATE: 4-20-70		DES. BY: JWS CHECK BY: JJK SHEET NO. 42 OF 118	

FILE NO.	DATE	REV.	BY	DATE
2	MD	1-95-4-32	43	112

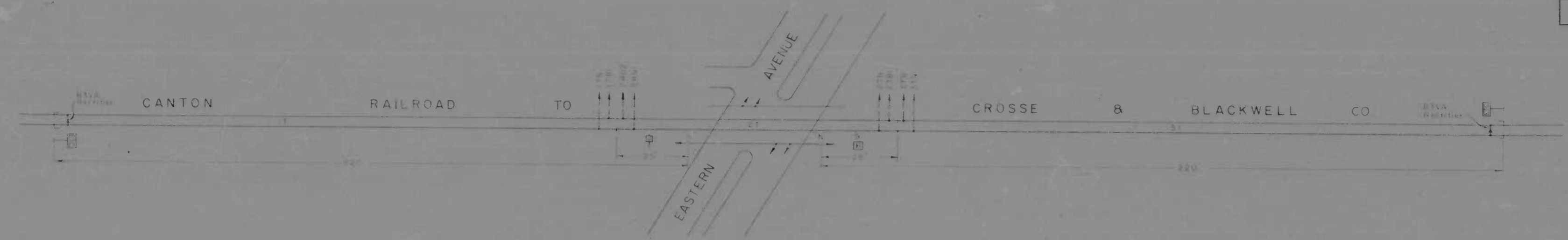

GENERAL NOTES:

- 1. Complete the design for traffic signals, including all related appurtenances.
- 2. 12" x 12" x 1/4" steel traffic signals (1-1/2" x 4-1/2" x 1/4" steel) shall be furnished by the Dept. of Transport & Traffic.
- 3. Operating Section Rules on Maximum Speeds of 50 MPH.
- 4. Track circuit to be installed by Contractor.
- 5. Signal design to be finished & installed by the Contractor.
- 6. See Special Provisions for further information.

EXISTING CROSSING PROTECTION
NOT TO SCALE

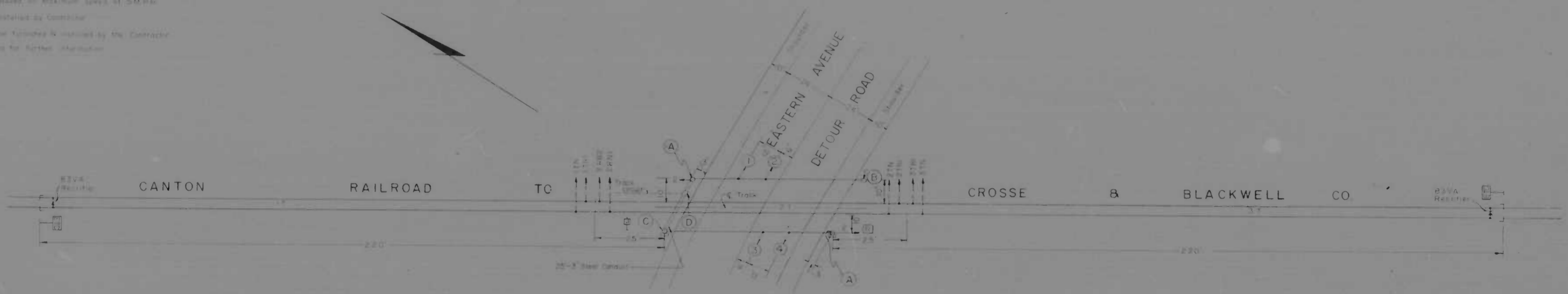

PROPOSED CROSSING PROTECTION
NOT TO SCALE

For Details See Sheet No. 57
For Box See Sheet No. 57
For Traffic Cross Section, Detour Road See Sheet No. 11

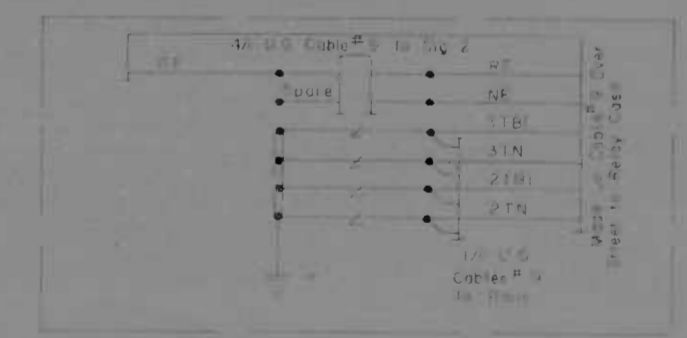

EXISTING RACO POLE BOX (1531-1)
NOT TO SCALE

GRADE CROSSING LEGEND

- Block Connection
- Rectifier
- Two Track Circuit Wire
- Insulated Joint
- Signal Mast
- Signal Mast Support

GRADE CROSSING PROTECTION
AT
EASTERN AVE. DETOUR ROAD

REVISIONS	CONSULTANT	CITY OF BALTIMORE DEPARTMENT OF PUBLIC WORKS	STATE ROADS COMMISSION OF MARYLAND INTERSTATE DIVISION FOR BALTIMORE CITY
	ENBERG, BENDER, STONE & ASSOC., INC. AND WATZ CHADS & ASSOC., INC. CONSULTING ENGINEERS 341 N. CALVERT STREET BALTIMORE, MARYLAND 21202	INTERSTATE ROUTE 95 EASTERN AVENUE INTERCHANGE	DRAWN BY: JWC TRACED BY: ACR DES BY: JWC CHK BY: DES
		SCALE: As Shown	DATE: 10-4-89
			F.P. NO. 1-95-4-32-36 S.R.C. NO. BC 240-23-915 BALTO. CITY NO. 880
			SHEET NO. 43 of 112

DATE	NO.	BY	REVISION
2	MD	195-9(32)	36 44 113

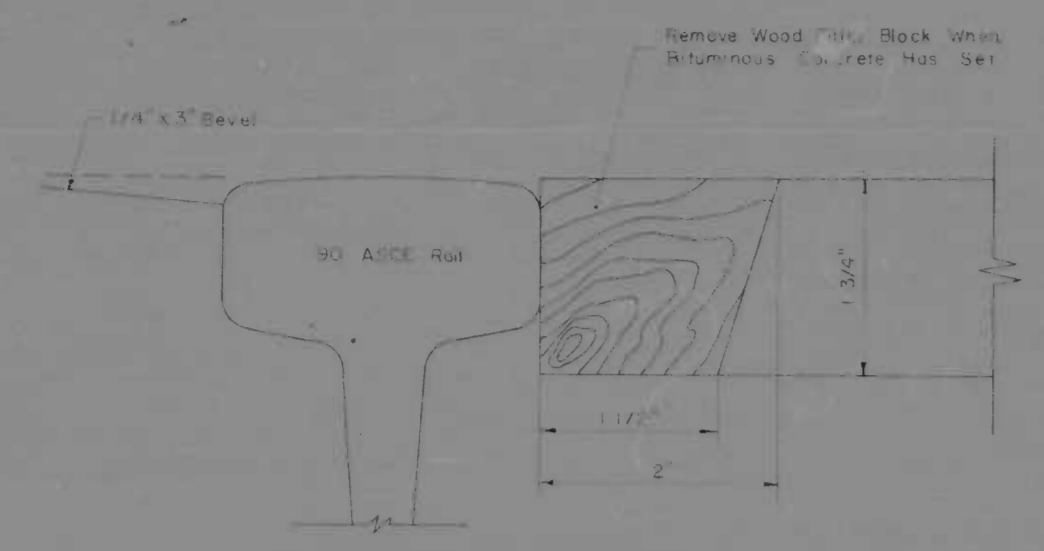

DETAIL 'B'
Flangeway And Bevel Detail
Scale 1" = 1"

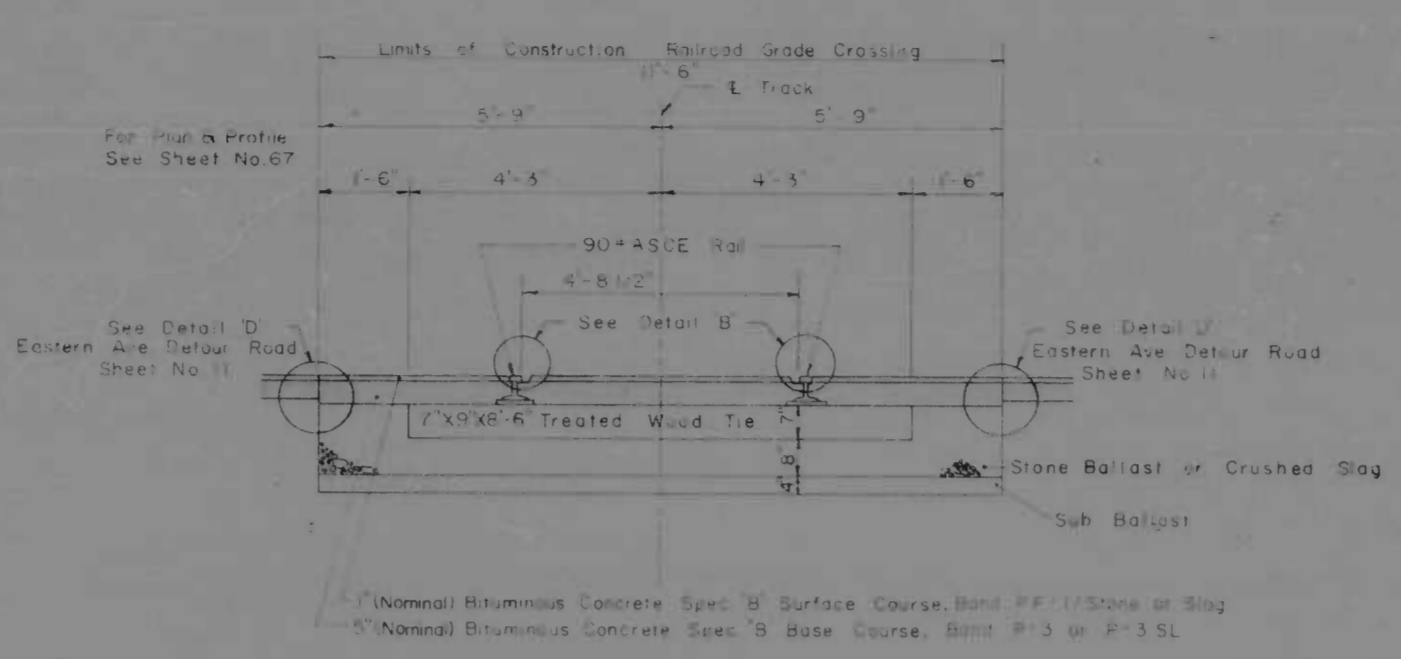

GRADE CROSSING-SECTION
Scale 1/2" = 1'-0"

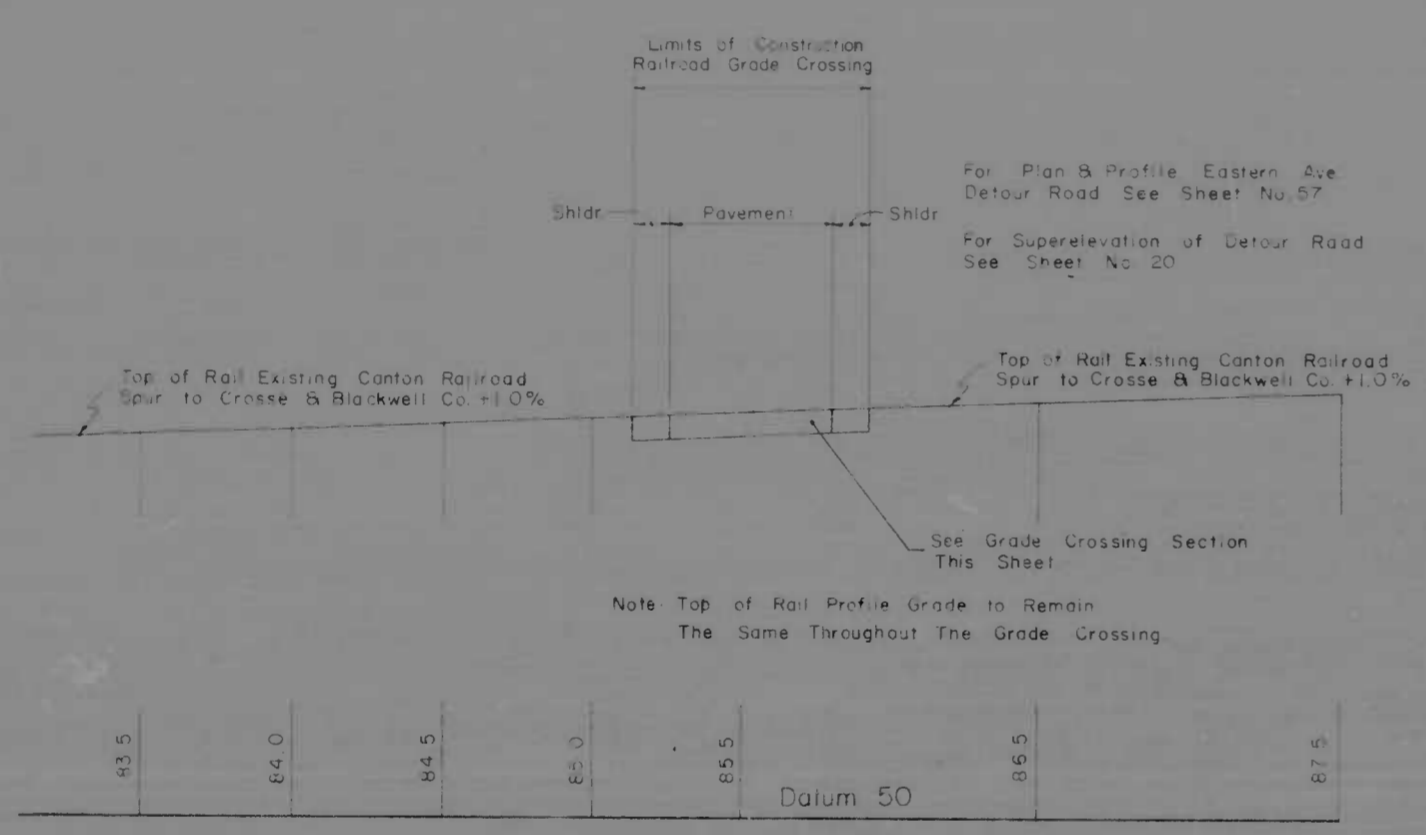

GRADE CROSSING - PROFILE & TRACK
Scale Horiz 1" = 40'
Vert 1" = 10'

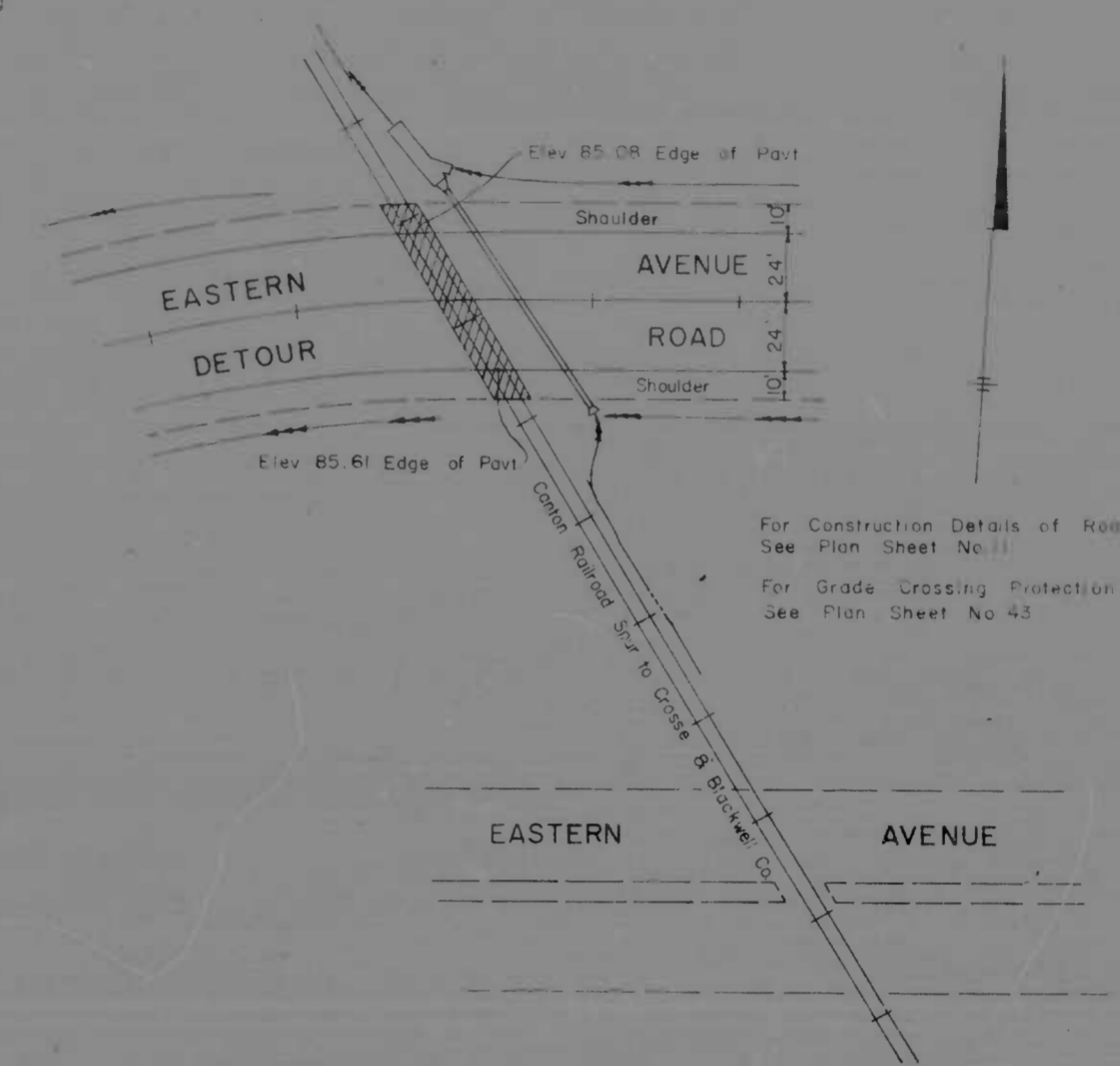

GRADE CROSSING - PLAN
Scale 1" = 40'

**CANTON RAILROAD SPUR TO CROSSE & BLACKWELL CO.
AT
EASTERN AVENUE DETOUR ROAD
GRADE CROSSING DETAILS**

REVISIONS	CONSULTANT	CITY OF BALTIMORE DEPARTMENT OF PUBLIC WORKS	STATE ROADS COMMISSION OF MARYLAND INTERSTATE DIVISION FOR BALTIMORE CITY	
	KNORRLE, BENDER, STONE & ASSOC., INC. 4411 MATZ, CHILDS & ASSOC., INC. CONSULTING ENGINEERS 381 N. CALVERT STREET BALTIMORE, MARYLAND 21202		INTERSTATE ROUTE 95 EASTERN AVENUE INTERCHANGE	DRAWN BY J.W.C. TRACED BY A.C.B. F.A.P. NO. 1-55-41521-36 S.R.C. NO. 256-25-805 BALTO. CITY NO. 1959
SCALE As Shown		DATE 10-1-59	SHEET NO. 44 of 113	

2	MD	95-4137-16	45	113
---	----	------------	----	-----



GRADING PLAN
RAMPS 'A' & 'D'

REVISIONS	CONSULTANT	CITY OF BALTIMORE	STATE ROADS COMMISSION OF MARYLAND
	KWIERLE, BENDER, STONE & ASSOC., INC. AND MATZ CHILDS & ASSOC., INC. CONSULTING ENGINEERS 341 N. ALBERT STREET BALTIMORE, MARYLAND 21202	DEPARTMENT OF PUBLIC WORKS	INTERSTATE DIVISION FOR BALTIMORE CITY
		INTERSTATE ROUTE 95	DRAWN BY J.S.C.
		EASTERN AVENUE INTERCHANGE	DESIGNED BY J.S.C.
		SCALE 1" = 40'	DATE 02-79
			DRAWN BY M.F.M.
			CHECKED BY D.E.S.
			F.A.P. NO. 1-58-4137-16
			S.R.C. NO. BC 746-29-R15
			BALTO. CITY NO. 359
			SHEET NO. 45 OF 113

NO.	DATE	BY	CHK'D
2	MD	95-43236	95

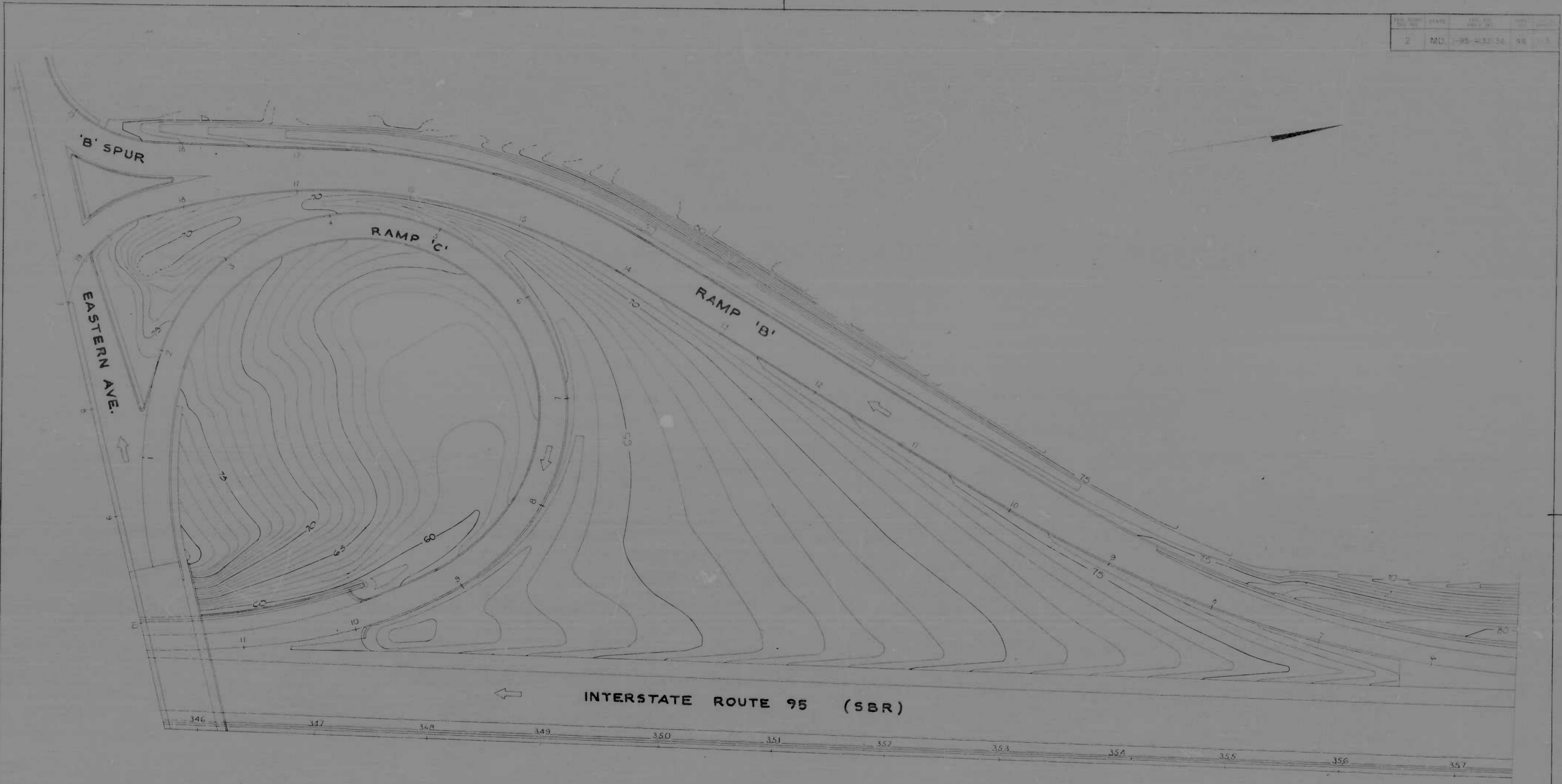

GRADING PLAN
RAMP 'B' & 'C'

REVISIONS	CONSULTANT	CITY OF BALTIMORE DEPARTMENT OF PUBLIC WORKS	STATE ROADS COMMISSION OF MARYLAND INTERSTATE DIVISION FOR BALTIMORE CITY
	KNOXELL BENDER, STONE & ASSOC., INC. AND HATT, CHILDS & ASSOC., INC. CONSULTING ENGINEERS 317 N. CALVERT STREET BALTIMORE, MARYLAND 21202	INTERSTATE ROUTE 95 EASTERN AVENUE INTERCHANGE	DRAWN BY: J.S.C. TRACED BY: M.P.H. F.P. NO. 95-43236 S.R.C. NO. 95-43236-815 BALTO. CITY NO. 1359
		SCALE: 1"=40'	DATE: 6-1-70

2	MD	1-95-0182736	47	113
---	----	--------------	----	-----

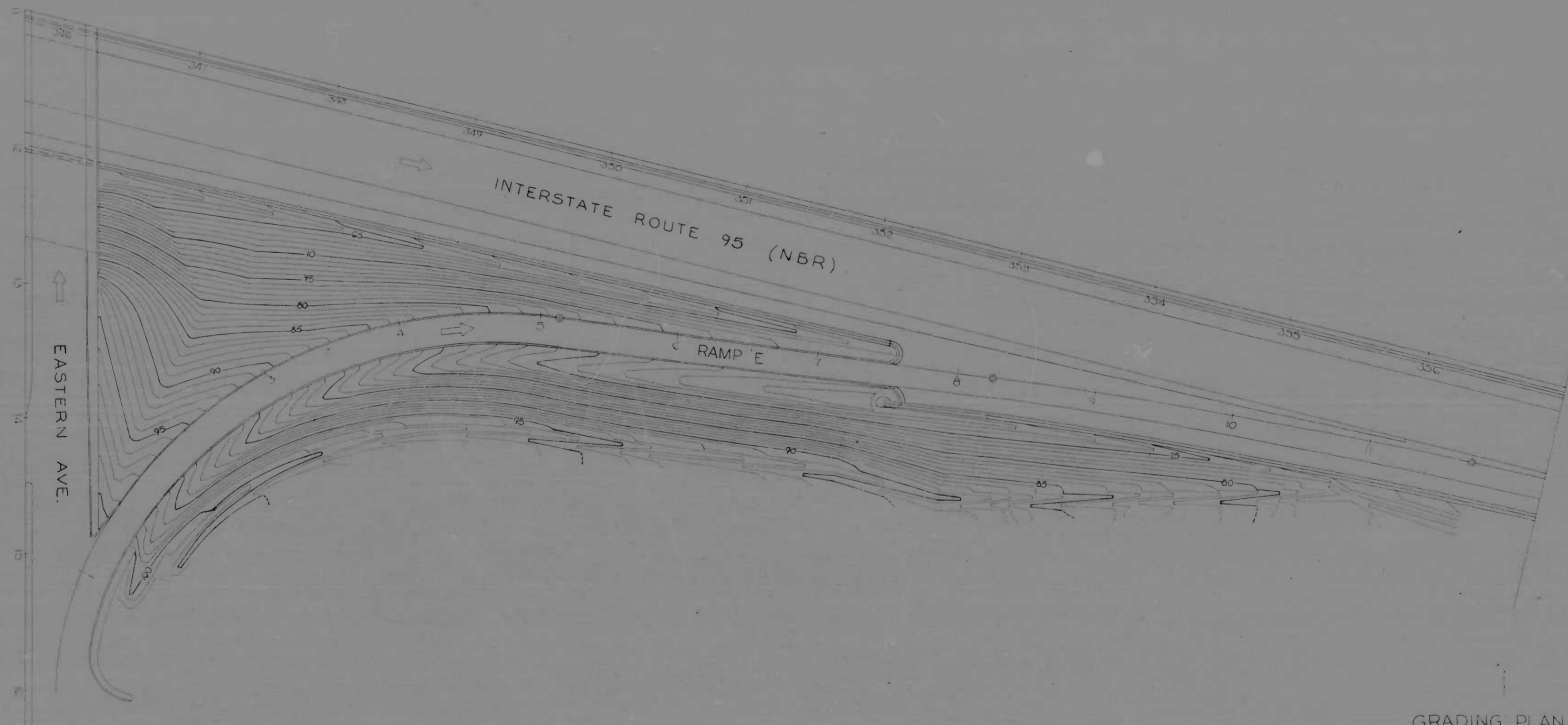

GRADING PLAN
RAMP E

REVISIONS	CONSULTANT	CITY OF BALTIMORE DEPARTMENT OF PUBLIC WORKS	STATE ROADS COMMISSION OF MARYLAND INTERSTATE DIVISION FOR BALTIMORE CITY	
	KNOERLE, BENDER, STONE & ASSOC., INC. MATZ CHIDS & ASSOC., INC. CONSULTING ENGINEERS 341 N. CALVERT STREET BALTIMORE, MARYLAND 21202	INTERSTATE ROUTE 95 EASTERN AVENUE INTERCHANGE	DRAWN BY: JJK TRACED BY: JJK I.P.C. NO. 95-0182736 S.R.C. NO. BC 246-29-010 BALTO. CITY NO. 359	CHK BY: DES SHEET NO. 47 OF 113
		SCALE: 1" = 40'	DATE: 4-1-70	



GRADING PLAN
RAMP 'F'

REVISIONS	CONSULTANT	CITY OF BALTIMORE	STATE ROADS COMMISSION OF MARYLAND
	KNOERLE, BERGER, STONE & ASSOC., INC.	DEPARTMENT OF PUBLIC WORKS	INTERSTATE DIVISION FOR BALTIMORE CITY
	MATZ, CHILDS & ASSOC., INC.	INTERSTATE ROUTE 95	DRAWN BY: J.D.C.
	CONSULTING ENGINEERS	EASTERN AVENUE INTERCHANGE	TRACED BY: E.L.M.
	341 N. CALVERT STREET		CHEK BY: D.E.S.
	BALTIMORE, MARYLAND 21202	SCALE: 1" = 40'	DATE: 6-3-70
			SHEET NO. 48 of 113

FED. ROAD DIST. NO.	STATE	FED. AID PROJ. NO.	SHEET NO.	TOTAL SHEETS
2	MD	1-95-4130136	49	113



PLAN SHEET INDEX

REVISIONS	CONSULTANT	CITY OF BALTIMORE	STATE ROADS COMMISSION OF MARYLAND
	KENDRICK, BENDER, STONE & ASSOC., INC. AND MATZ, CHLOS & ASSOC., INC. CONSULTING ENGINEERS 841 N. CALVERT STREET BALTIMORE, MARYLAND 21202	DEPARTMENT OF PUBLIC WORKS	INTERSTATE DIVISION FOR BALTIMORE CITY
		INTERSTATE ROUTE 95	DRAWN BY: JDM
		EASTERN AVENUE INTERCHANGE	DES. BY: D.E.S.
		SCALE: 1" = 100'	DATE: 4-27-70
			TRACED BY: JDM
			CHK. BY: V.F.H.
			S.R.C. NO. BS 226-29-82
			BALTO. CITY NO. 1959
			SHEET NO. 49 OF 113

FILE NO.	STATE	PROJECT NO.	SHEET NO.	TOTAL SHEETS
2	MD	1-85-413215E	5	113

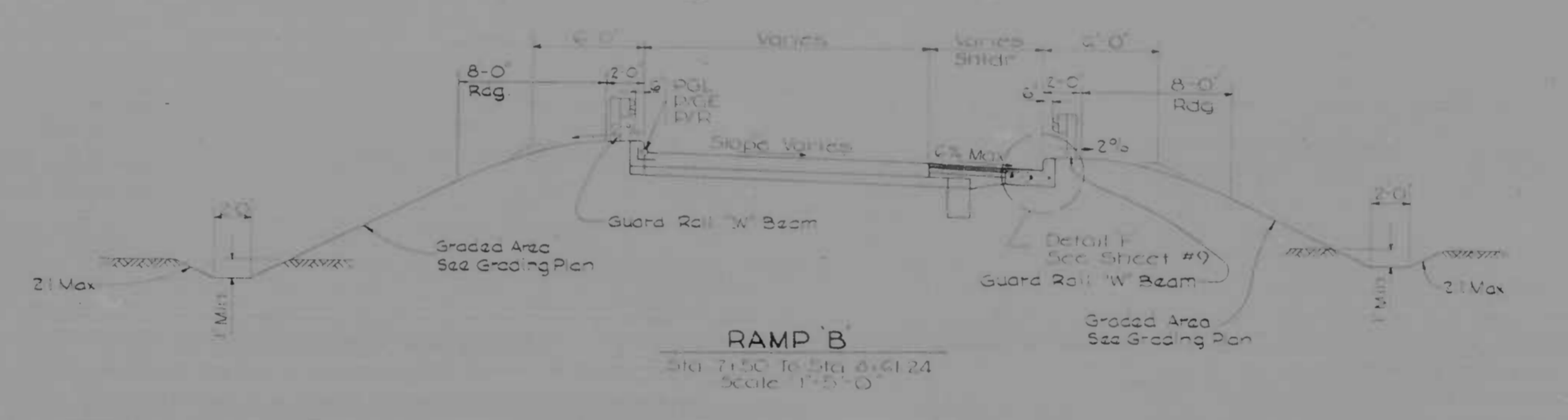
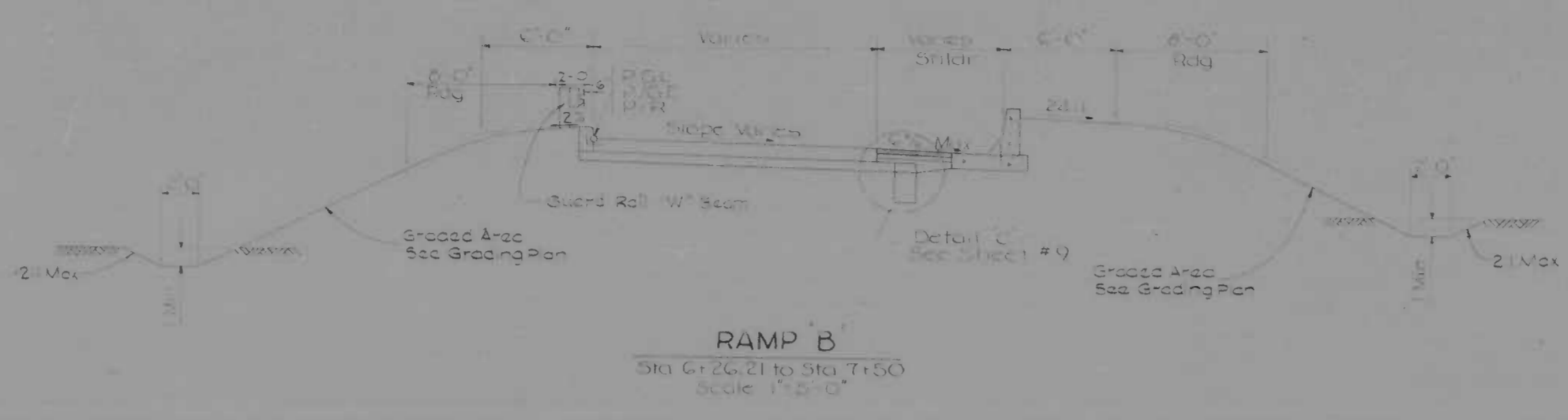

Note:
All Side Slopes - 2% Topsoil, Seed and Mulch

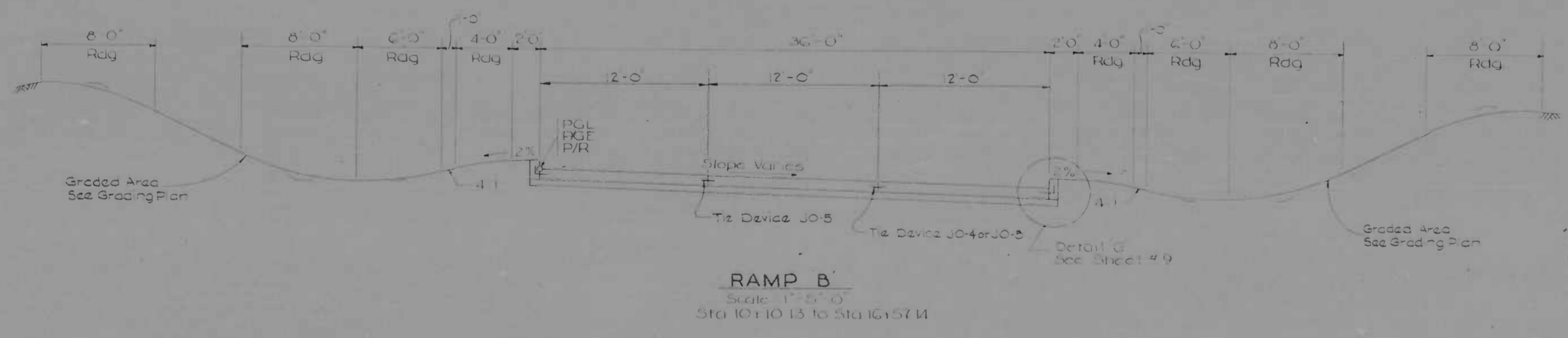

REVISIONS	CONSULTANT	CITY OF BALTIMORE DEPARTMENT OF PUBLIC WORKS	STATE ROADS COMMISSION OF MARYLAND INTERSTATE DIVISION FOR BALTIMORE CITY
	KNORRLE, BENDER, STONE & ASSOC., INC. WATZ, CHILDS & ASSOC., INC. CONSULTING ENGINEERS 341 N. EASLEY STREET BALTIMORE, MARYLAND 21202	INTERSTATE ROUTE 35 EASTERN AVENUE INTERCHANGE	DRAWN BY: WJS TRACED BY: JJK F.A.P. NO. 1-16-413215E S.P.C. NO. RC 206-23-8-5 BALTO. CITY NO. 8779
		SCALE: As Shown	DATE: 4-20-70
			DWG. BY: DFB CHK. BY: SWM SHEET NO. 5 of 113

NO.	DATE	BY	CHKD.
2	MD 1-19-67

LIMIT OF WORK
 STA 324+00
 PAV'G NO. 1-95-415210C
 SFR. NO. 8-C 327-71.02
 BALTO CITY NO. 1959

CONSTRUCT GUARD RAIL W BEAM.
 RAMP 1 STA 3400.0 STA 3400.0 57' L.F.
 RAMP 2 STA 3477.0 STA 3477.0 191' L.F.
 Note: Flow Guard 20' to West End of Concrete
 Barrier Sta 3477.0 21' Comp.



CROSS REFERENCE TABLE

ITEM	SHEET NO.
Profile - 1-30	51
Profile - 1-30	57
Grading Plan - Camp F	48
1" x 12" 10' Long	35
Storm Sewer Profile	75 (Pav. 77)
Sanitary Sewer Profile	78
General - Curb Transition	12
Joint - Joints	19
Retaining Wall	30
Manhole and Inlet Schedule	38

CURVE	Δ	D	R	T	L	E	S
1-2	14.742	380	324.436	126.88	53.187	436.60	374.67
1-3	17.492	310	261.56	103.22	43.66	346.36	271.55
1-4	17.492	310	261.56	103.22	43.66	346.36	271.55

IDENT	NO.	Δ	D	L	T	LC	Rc	Os	Es	SE
1-2	30	34.3072	300000	650270	128.96	524.07	1245.92	1212.20	1222.20	110.08

PAVEMENT LEGEND

- 8" Continuous Reinforced Cement Concrete
- 9" Conventional Reinforced Cement Concrete
- Flexible Pavement

SANITARY SEWER MANHOLE SCHEDULE

NO.	LOCATION	NORTH COORDINATES	EAST COORDINATES	TYPE
11	331+33 R1 1-95	-4886.01	22,715.07	514 MM

REVISIONS	CONSULTANT ANDRELL BENDER STONE & ASSOC., INC. MTC CONSULTING ENGINEERS 841 N. CALVERT STREET BALTIMORE, MARYLAND 21202	CITY OF BALTIMORE DEPARTMENT OF PUBLIC WORKS INTERSTATE ROUTE 95 EASTERN AVENUE INTERCHANGE	STATE ROADS COMMISSION OF MARYLAND INTERSTATE DIVISION FOR BALTIMORE CITY
	SCALE: 1" = 40'	DATE: 4-27-70	

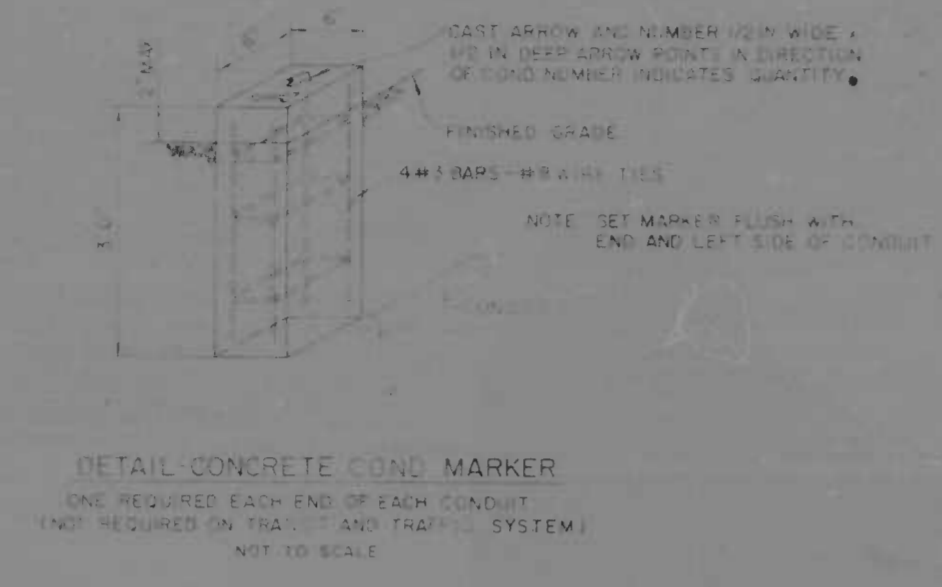
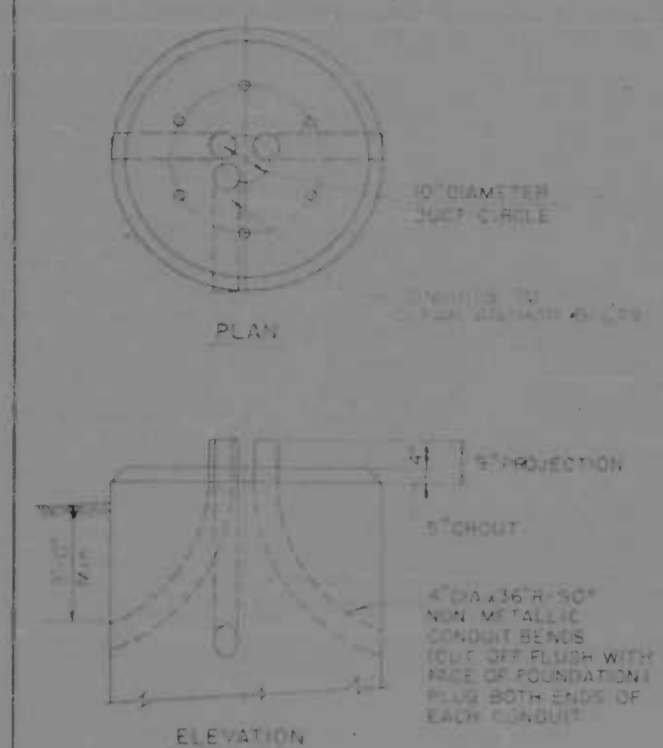

DETAIL-THREE WAY DUCT ENTRANCE IN LIGHTING STANDARD FOUNDATION
 SINGLE AND TWO-WAY DUCT ENTRANCES SIMILAR
 NOT TO SCALE

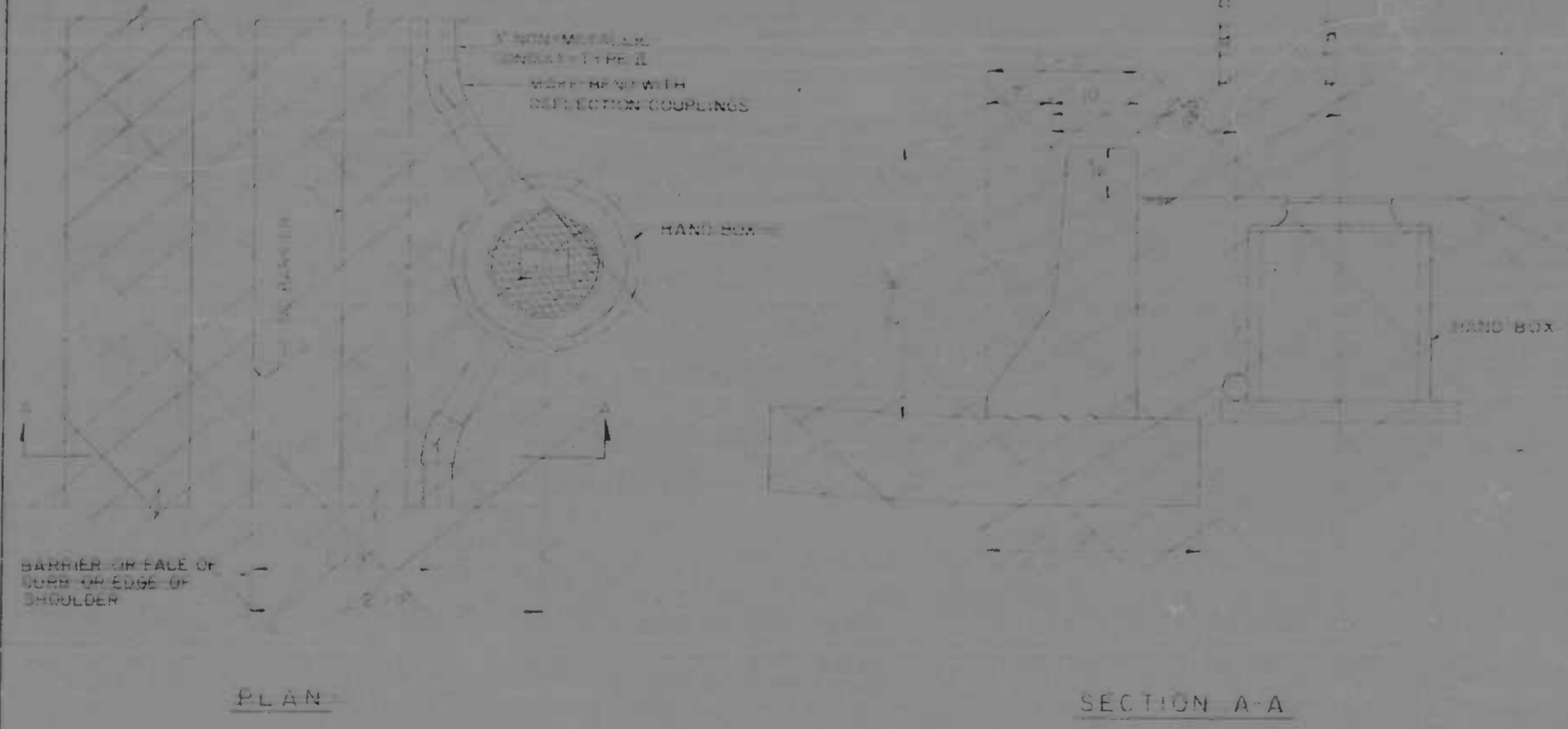
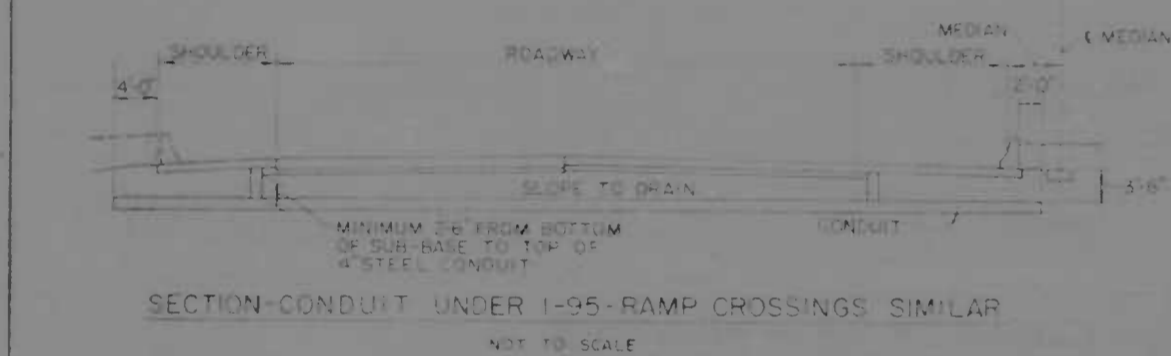

TRANSIT AND TRAFFIC HAND BOX & DUCT LOCATION
 NOT TO SCALE



- LEGEND
- PROPOSED FOUNDATION FOR HIGH MAST LIGHT STANDARD
 - PROPOSED FOUNDATION FOR CANTILEVER SIGN
 - PROPOSED FOUNDATION FOR OVERHEAD SIGN BRIDGE
 - PROPOSED 4" STEEL CONDUIT
 - PROPOSED COND MARKER
 - PROPOSED TRANSIT AND TRAFFIC DUCT
 - PROPOSED TRANSIT AND TRAFFIC HAND BOX
 - PROPOSED TRANSIT AND TRAFFIC MANHOLE
 - GUARD RAIL TO BE INSTALLED UNDER ORIGINAL CONTRACT

REVISIONS	CONSULTANT	CITY OF BALTIMORE DEPARTMENT OF PUBLIC WORKS	STATE ROADS COMMISSION OF MARYLAND INTERSTATE DIVISION FOR BALTIMORE CITY
Addition to Existing Contract 11-19-11	KUDERLE, BENDER, STONE & ASSOC., INC. MATZ, CAHILL & ASSOC., INC. CONSULTING ENGINEERS 941 N. AVENUE SUITE 101 BALTIMORE, MARYLAND 21202	INTERSTATE ROUTE 95 EASTERN AVENUE INTERCHANGE	DRAWN BY: J. J. JONES E.C.P. NO. 10-19-11-00 S.A.E. NO. BC-14021-11-01 DATE: 10/13/11

MATCH LINE SEE SHEET NO 53

CONSTRUCT GUARD RAIL W BEAM
 RAMP E STA 5110 TO STA 5100 L+93.1F
 RAMP F STA 5143 TO STA 5179 R+31.1F



Note: Build Sanitary Sewer Manhole No. 13 on Existing 6" Sanitary Sewer

NOTE: FOR SLOPE DIRECTION AT CANTON RAIL ROAD STRUCTURE SEE SHEET NO 50

CURVE NO	Δ	D	R	T	L	E	SE
D-1	34°48'19"	8107.29	372.48	472.37	337.75	66.49	
D-2	77°26'50"	2730.00	16.37	52.55	312.79	3.50	
D-3	70°25'30"	1837.00	703.25	78.12	59.35	1.51	
D-4	77°26'50"	2730.00	16.47	52.55	312.79	3.50	6025'
D-5	14°37'48"	1173.30	174.88	73.82	336.67	270.69	10.07'

IDENT	CURVE NO	Δ	D	Ls	Ts	Lc	Rc	Os	Es	SE
1-95	10	84°37'20"	2700.00	850.00	1372.94	1040.07	1145.92	16' 15.00"	422.90	1+0.00

SANITARY SEWER MANHOLE SCHEDULE				
NO	LOCATION	COORDINATES		TYPE
		NORTH	EAST	
12	Sta. 2+198	4696.90	22250.29	5' S.M.A.
13	Sta. 3+144	4690.82	22266.07	4' DING

CROSS REFERENCE TABLE	
ITEM	SHEET NO
Profile I-95	51
Profile Ramp D	57
Grading Plan Ramp D	45
Gore Detail Ramp D	33
Storm Sewer Profile	73 thru 77
Sanitary Sewer Profile	78
Joint Details	35A-40
Manhole and Inlet Schedules	58
Cul-de-sac Detail	8

PAVEMENT LEGEND

- R Continuous Reinforced Cement Concrete
- S Conventional Reinforced Cement Concrete
- Flexible Pavement

REVISIONS	CONSULTANT	CITY OF BALTIMORE DEPARTMENT OF PUBLIC WORKS	STATE ROADS COMMISSION OF MARYLAND INTERSTATE DIVISION FOR BALTIMORE CITY
	KNORRLE ENGINEERING & ARCHT. INC. BATE, CHES & SHINE, INC. CONSULTING ENGINEERS 341 BALTIMORE STREET BALTIMORE, MARYLAND 21202	INTERSTATE ROUTE 95 EASTERN AVENUE INTERCHANGE	DRAWN BY: WFE TRACED BY: RFF F.A.R. NO. 1000-114106 S.R.C. NO. 25-241-25-001 BALTO CITY NO. 509
		SCALE: 1"=50'	DATE: 5/27/75

MATCH LINE SEE SHEET NO 53A

DATE: 11-16-11
 SHEET NO: 53A-14-13



LEGEND

- PROPOSED FOUNDATION FOR LIGHT STANDARD
- PROPOSED FOUNDATION FOR GANTRY BEAM
- PROPOSED FOUNDATIONS FOR OVERHEAD SIGN BRIDGE
- PROPOSED 4" STEEL CONDUIT
- PROPOSED CONC. MARKER
- PROPOSED TRANSIT AND TRAFFIC SIGN
- ▲ PROPOSED TRANSIT AND TRAFFIC SIGN
- PROPOSED TRANSIT AND TRAFFIC MARKER
- PROPOSED GUARD RAIL W/ BEAM
- GUARD RAIL TO BE INSTALLED UNDER ORIGINAL CONTRACT



DETAILS - FOUNDATION CONDUIT ENTRANCES

REVISIONS Addition to Contract Contract 11-16-11	CONSULTANT KNOWLE BIKER STONE & STONE, INC. MATT CHILDS & ASSOC. INC. CONSULTING ENGINEERS 1111 N. W. STREET BALTIMORE, MARYLAND 21201	CITY OF BALTIMORE DEPARTMENT OF PUBLIC WORKS		STATE ROADS COMMISSION OF MARYLAND INTERSTATE DIVISION FOR BALTIMORE CITY	
		INTERSTATE ROUTE 95 EASTERN AVENUE INTERCHANGE	DRAWN BY TRAVIS A. ELLIOTT	CHECKED BY JIMMY L. HARRIS	SHEET NO. 53A-14-13

NO.	LOCATION	COORDINATES	TYPE
1	See Map	2437.30	8'x8' M.H.
2	See Map	2437.30	8'x8' M.H.

B.M. 7733 Elev. 93.903
 7'x16' Box in East End of Sewer Main
 at Intersection of Eastern Avenue
 and Conroy Street, 0.5' from North End
 of Conroy Street.

B.M. 6876 Elev. 77.701
 8'x16' Box in East End of Sewer Main
 at Front of No. 6844 Equivex Avenue
 400' East of Canton Railroad Tracks
 0.50' East of East End of Equivex Avenue

B.M. 6877 Elev. 106.779
 8'x16' Box in East End of Sewer Main
 at Intersection of Eastern Avenue
 and Conroy Street, 0.50' East of East
 End of Conroy Street.

2	MD	198-402-26	52	113
---	----	------------	----	-----

NOTE FOR SLOPE PROTECTION AT
 EASTERN AVE. STRUCTURE
 SEE SHEET NO. 50

Note: Build Sanitary Sewer Manhole No. 1
 at Tapping to Sanitary Sewer

FOR THE TOP OF VERTICAL CURB
 OPENING, SEE SHEET NO. 50 OR 51



NO.	Δ	D _c	D _t	T	L	E	SE
1	90°00'00"	200.00	200.00	282.84	141.42	141.42	+0.09%
2	90°00'00"	200.00	200.00	282.84	141.42	141.42	+0.09%
3	90°00'00"	200.00	200.00	282.84	141.42	141.42	+0.09%
4	90°00'00"	200.00	200.00	282.84	141.42	141.42	+0.09%
5	90°00'00"	200.00	200.00	282.84	141.42	141.42	+0.09%
6	90°00'00"	200.00	200.00	282.84	141.42	141.42	+0.09%
7	90°00'00"	200.00	200.00	282.84	141.42	141.42	+0.09%
8	90°00'00"	200.00	200.00	282.84	141.42	141.42	+0.09%
9	90°00'00"	200.00	200.00	282.84	141.42	141.42	+0.09%
10	90°00'00"	200.00	200.00	282.84	141.42	141.42	+0.09%

ITEM	SHEET NO.
Profile - SBRI	53
Profile - Ramps A, C, D, E, F	54, 55, 56, 57, 58
Profile - Eastern Ave. Structure	59
Retaining Wall	60, 61, 62
Grading Plan - Range XNC B D	63, 64, 65
Sanitary Sewer Profile	66
Water Sewer Profile	67
Manhole & Inlet Schedule	68
Intersection Details	69
Gate Details - Range ADT	70, 71
Detail - Box	72
Joint Details	73
Bridge - Plans	74, 75, 76

LIMIT OF WORK
 STA 20+92
 EAST MD 198-402-26
 SRC No BC 240 27 815
 BALTO. CITY No 1959

REVISION LEGEND

- 1" Greenhouse Reinforced Concrete
- 1" Greenhouse Reinforced Cement Concrete
- Flexible Pavement
- Feather to Meet Existing Pavement

Note: For Pavement Details See Sheet No. 5 & 6

REVISIONS	CONSULTANT EMPALE, DUNDA, STARK & ASSOC., INC. AND NATZ, CHILDS & ASSOC., INC. CONSULTING ENGINEERS 341 N. CALVERT STREET BALTIMORE, MARYLAND 21202	CITY OF BALTIMORE DEPARTMENT OF PUBLIC WORKS	STATE ROADS COMMISSION OF MARYLAND INTERSTATE DIVISION FOR BALTIMORE CITY
		INTERSTATE ROUTE 95 EASTERN AVENUE INTERCHANGE	DRAWN BY: R.P.D. CHECKED BY: J.C.S. DESIGNED BY: J.C.S. DATE: 4-27-70

BM 7752 Elev. 86.004

Stone Cut in East End of Tower Hill
On South Side of Eastern Avenue 75'
West of the Center of Tower Hill
Close to Blackwell 0.35 from East
End 0.27 from Face

BM 7754 Elev. 94.448

Brick Wall in Concrete Fig. 2nd Base
and Northwest Corner of Eastern
Avenue and Park Street

REV. NO.	DATE	BY	CHKD.	APP. BY
2	MD	95-112736	52	12

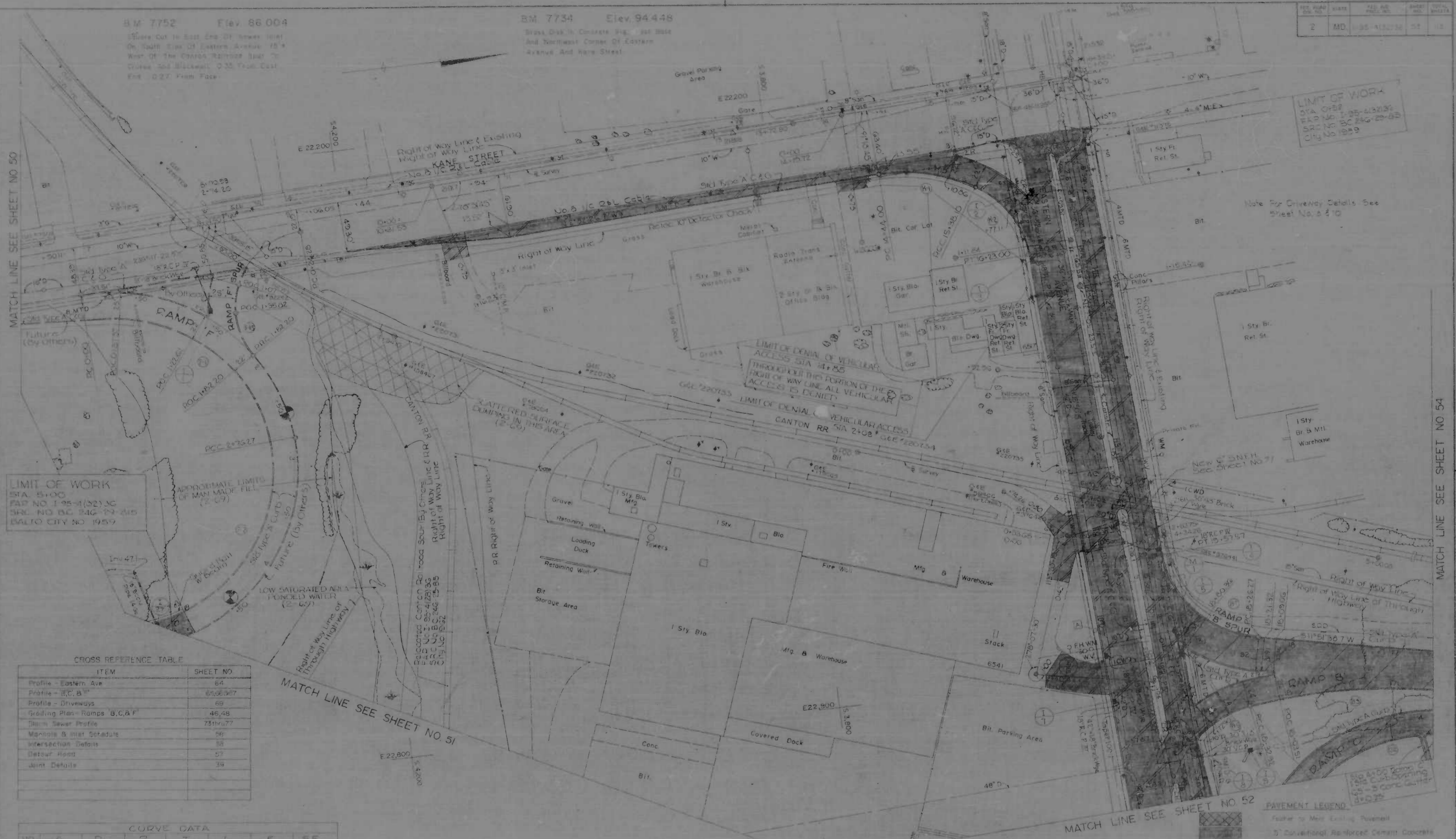

LIMIT OF WORK
STA. 5+00
PLAN NO. 1-95-112736
SHE. NO. 52 OF 54
BALTO CITY NO. 1959

CROSS REFERENCE TABLE

ITEM	SHEET NO.
Profile - Eastern Ave	54
Profile - B.C.B.	65, 66, 67
Profile - Driveways	69
Grading Plan - Ramps B, C, F	46, 48
Sanitary Sewer Profile	73, 74, 77
Manhole & Inlet Schedule	56
Intersection Details	58
Detail Road	57
Joint Details	39

CURVE DATA

NO.	Δ	Dc	D	T	L	E	SE
1	90°00'00"	31'43.52	120.00	106.00	252.75	74.56	+0.107
2	90°00'00"	11'22.13	475.00	220.91	473.21	51.00	+0.057
3	93°46'25"	57'1.45	100.00	69.66	129.21	34.37	+0.027
4	75°13'25"	57'11.45	100.00	71.05	131.30	26.24	+0.0637
5	90°00'00"	12'34.39	175.00	175.00	276.21	72.55	+0.107
6	90°00'00"	16'23.40	75.00	75.00	157.92	76.45	---
7	90°00'00"	50'11.99	150.00	48.69	28.10	7.62	---
8	90°00'00"	16'33.43	90.00	45.91	68.50	11.03	---
9	90°00'00"	14.32	75.00	72.83	438.60	319.68	+0.107

CONSTRUCT GUARD RAIL W/ BEAM
RAMP F STA 5+00 TO STA 5+43.41 3% LF

PAVEMENT LEGEND

	Flexible Pavement
	5" Conventional Reinforced Concrete
	5" Concrete

REVISIONS	CONSULTANT KIMBLE, BENDER, STONE & ASSOC., INC. MAYNARD & ASSOC., INC. CONSULTING ENGINEERS 341 N. CALVERT STREET BALTIMORE, MARYLAND 21202	CITY OF BALTIMORE DEPARTMENT OF PUBLIC WORKS INTERSTATE ROUTE 95 EASTERN AVENUE INTERCHANGE	STATE ROADS COMMISSION OF MARYLAND INTERSTATE DIVISION FOR BALTIMORE CITY DRAWN BY: W.F.P. CHECKED BY: J.P.H. DATE: 4/22/70
SCALE: 1"=40'	DATE: 4/22/70	SHEET NO. 52 OF 54	BALTO CITY NO. 1959

NO. OF SHEETS	NO. OF SHEETS	NO. OF SHEETS	TOTAL SHEETS
2	MD	1-15-1958	558 113

LEGEND

- PROPOSED FOUNDATION FOR HIGH MAST LIGHT STANDARD
- PROPOSED FOUNDATION FOR CANTILEVER SIGN
- PROPOSED FOUNDATIONS FOR OVERHEAD SIGN BRIDGE
- PROPOSED 4" STEEL CONDUIT
- PROPOSED CONDUIT MARKER
- PROPOSED TRANSIT AND TRAFFIC DUCT
- HB PROPOSED TRANSIT AND TRAFFIC HAND BOX
- MH PROPOSED TRANSIT AND TRAFFIC MANHOLE
- PROPOSED BOARD RAIL W/ BEAM
- △ ROADWAY LIGHT REPOSTAL BASE AND SOFT LIGHT STANDARD TO BE INSTALLED UNDER ORIGINAL CONTRACT
- HAND BOX TO BE INSTALLED UNDER ORIGINAL CONTRACT
- SENSOR ELEMENT TO BE INSTALLED UNDER ORIGINAL CONTRACT
- BOARD RAIL TO BE INSTALLED UNDER ORIGINAL CONTRACT

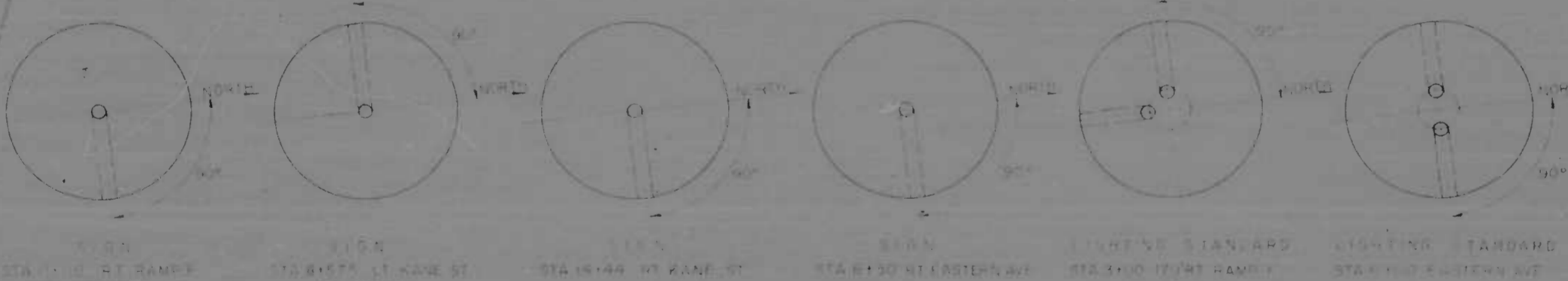
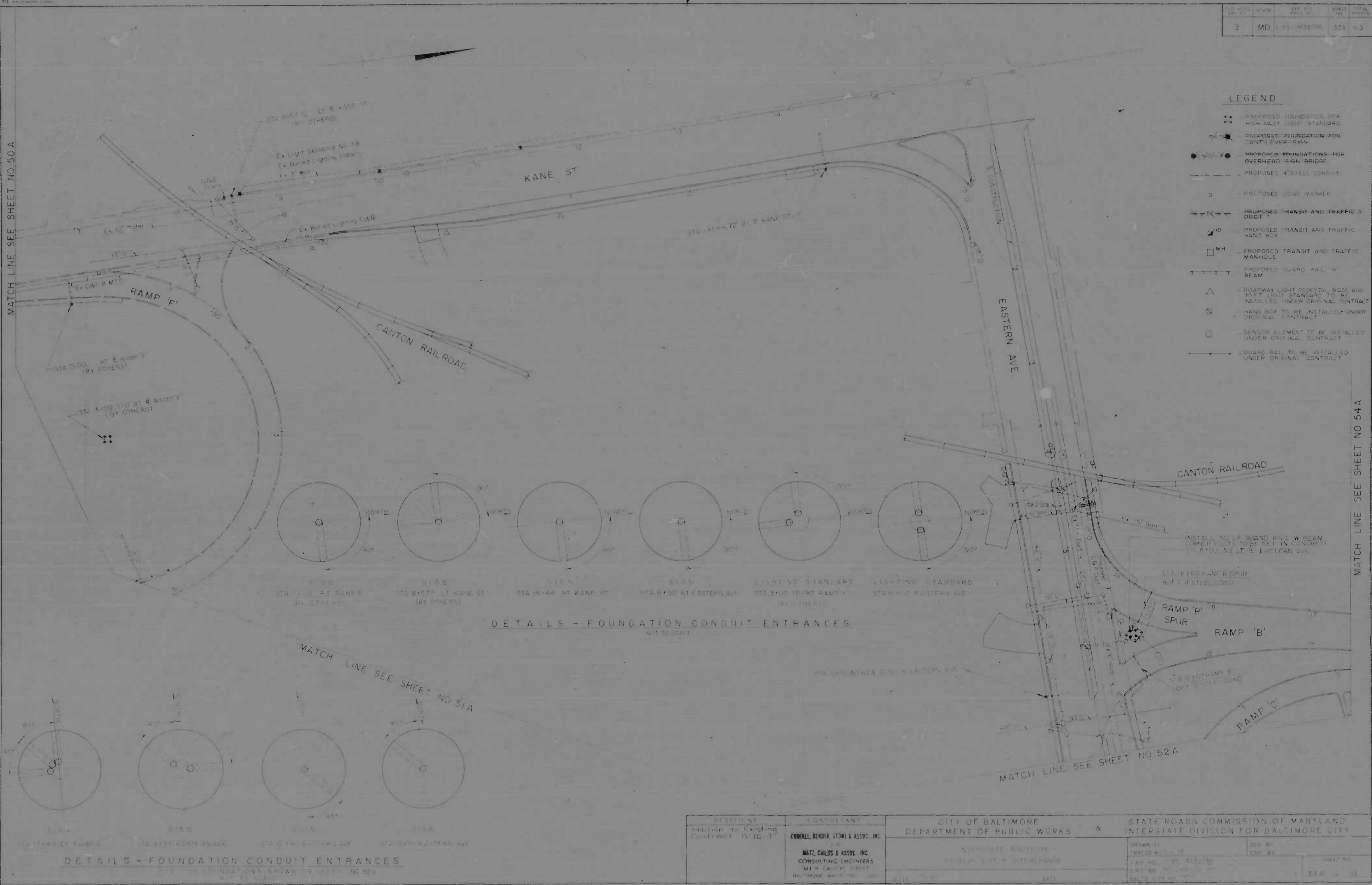

DETAILS - FOUNDATION CONDUIT ENTRANCES
1/4" = 1' TO SCALE

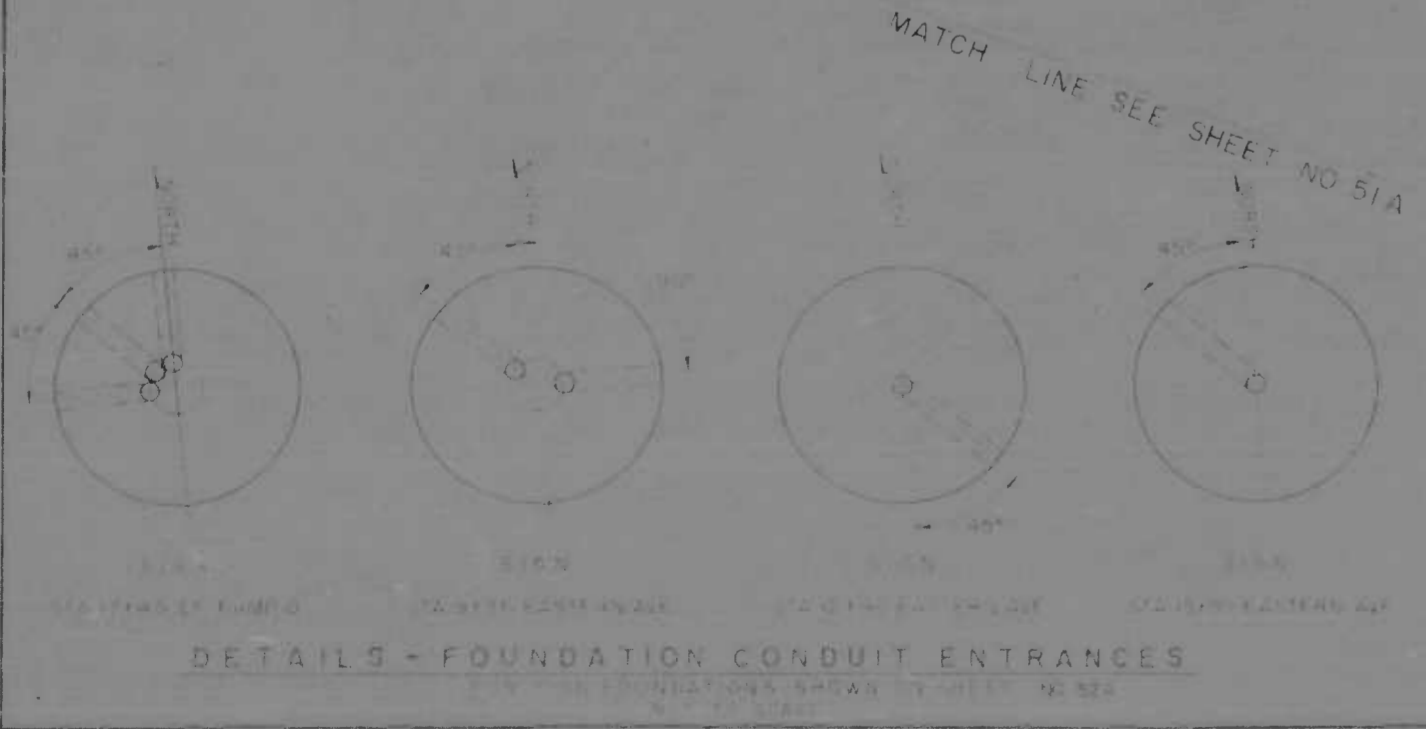

DETAILS - FOUNDATION CONDUIT ENTRANCES
1/4" = 1' TO SCALE

REVISIONS 1. REVISED AS EXISTING CONTRACT 11/10/11	CONSULTANT KENDRICK, BENDIS, STONE & ASSOC. INC. AND MATZ, GILLES & ASSOC. INC. CONSULTING ENGINEERS 341 N. CALVERT STREET BALTIMORE, MD 21202	CITY OF BALTIMORE DEPARTMENT OF PUBLIC WORKS	STATE ROADS COMMISSION OF MARYLAND INTERSTATE DIVISION FOR BALTIMORE CITY
PROJECT NO. 83-2145 83-2145 SUPERVISOR'S OFFICE	DRAWN BY: J. J. J. CHECKED BY: J. J. J. DATE: 11/10/11	SHEET NO. 558 113	DATE: 11/10/11

NO	LOCATION	COORDINATES		TYPE
		NORTH	EAST	
3	Sta 3+14.49	-3140.00	23786.00	Sid M.H.
4	Sta 6+64.49	-2790.35	23770.85	Sid M.H.



B M 7733 Elev 93.903
 Brass Screw In North End of Sewer Inlet On Southeast Corner Of Quinton Street And Conley Street 0.5' From North End 0.3' From Face

CURVE NO	Δ	D	R	T	L	E	SE
B-2	26°14'50.8"	5930.00'	104.74'	242.88'	477.23'	27.94'	-0.065%
B-3	26°14'50.8"	6757.40'	823.07'	191.89'	377.05'	22.07'	---
B-4	20°14'50.8"	6712.40'	325.41'	215.05'	422.56'	24.74'	---
C-2	90°00'00.0"	319.452'	180.00'	180.00'	282.74'	74.56'	-0.10%
C-3	106°18'59.1"	319.452'	180.00'	243.25'	334.00'	120.20'	-0.10%
C-4	30°02'15.5"	288.385'	200.00'	53.66'	104.85'	70.7'	-0.10%
C-5	20°10'49.2"	1489.26'	400.00'	71.18'	140.89'	6.28'	-0.10%
E-2	69°11'22.9"	1754.178'	320.00'	220.71'	386.43'	68.73'	---
E-3	51°12'27.1"	1932.00'	3819.71'	73.70'	347.17'	3.85'	---
B-5	50°43'46.1"	1159.12'	478.00'	226.61'	423.22'	51.00'	0.0055%

ITEM	SHEET NO
Profile - 1-95	52
Profile - Ramps 'B', 'C', 'E'	65, 66, 69
Grading Plan - Ramps 'B', 'C', 'E'	46, 64, 7
Gore Details - Ramps 'B', 'E'	31, 5, 34
Storm Sewer Profile	73 thru 77
Sanitary Sewer Profile	78
Manhole & Inlet Schedule	58
Detour Road	57
Joint Details	41

PAVEMENT LEGEND
 8' Continuous Reinforced Cement Concrete
 9' Conventional Reinforced Cement Concrete

REVISIONS CONSULTANT KNORR, BENDER, STONE & ASSOC., INC. AND MATZ GILDS & ASSOC., INC. CONSULTING ENGINEERS 341 N. CALVERT STREET BALTIMORE, MARYLAND 21202	CITY OF BALTIMORE DEPARTMENT OF PUBLIC WORKS & STATE ROADS COMMISSION OF MARYLAND INTERSTATE ROUTE 95 EASTERN AVENUE INTERCHANGE	INTERSTATE DIVISION FOR BALTIMORE CITY DRAWN BY: WFF TRACED BY: WFF F.A.P. NO. 1-95-413036 S.R.C. NO. 95-206-29-R5 BALTO. CITY NO. 1150	DES. BY: J.W.C. CHK. BY: D.E.S. SHEET NO. 54 OF 113
	SCALE: 1" = 30' DATE: 4/27/70		

CONSTRUCT GUARD RAIL W/ BEAM
 "RAMPE" STA 2+96 TO STA 7+09 LT 419' LF

NO.	DATE	BY	REVISION
2	MD		

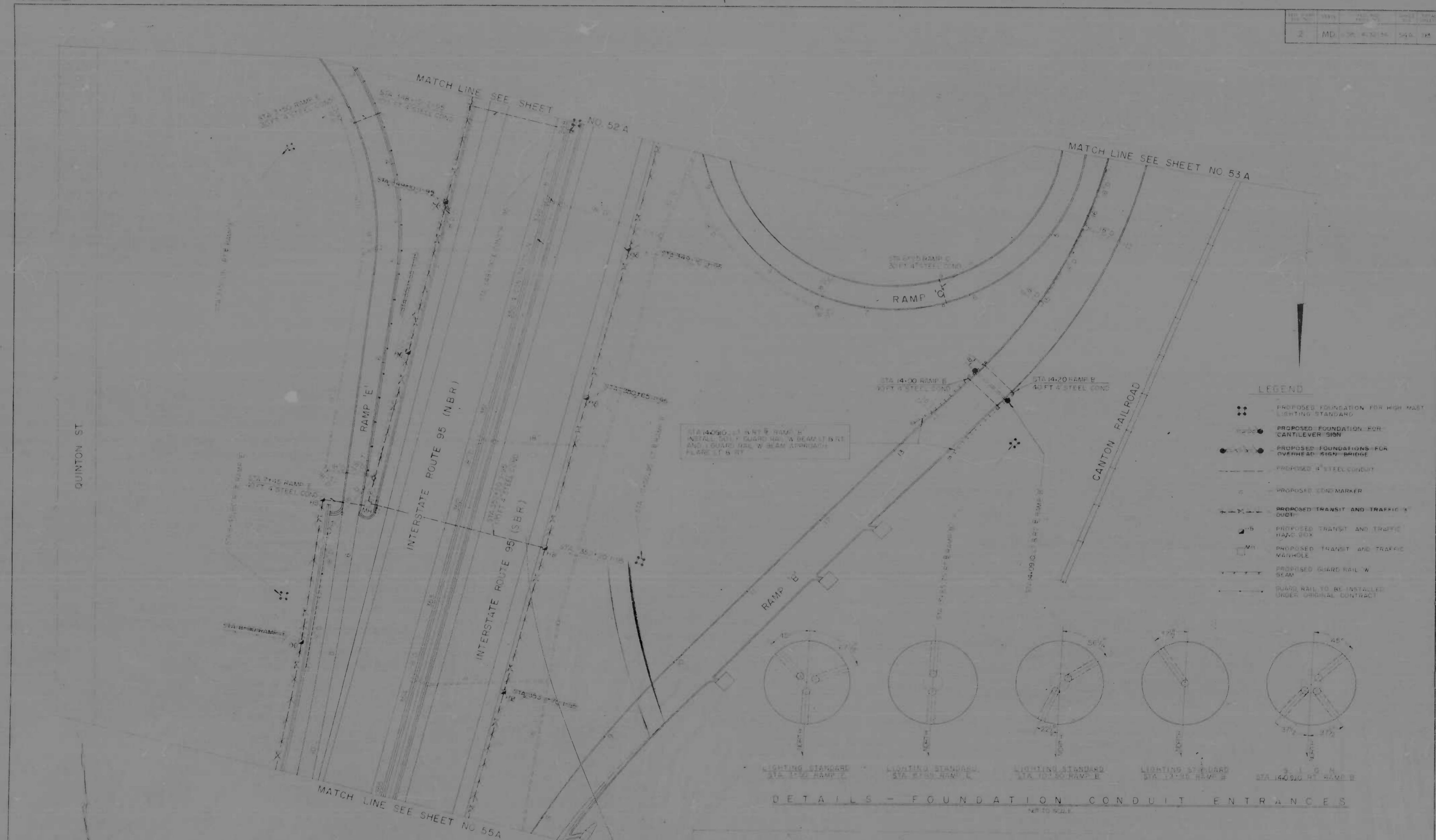

- LEGEND**
- PROPOSED FOUNDATION FOR HIGH MAST LIGHTING STANDARD
 - PROPOSED FOUNDATION FOR CANTILEVER SIGN
 - PROPOSED FOUNDATIONS FOR OVERHEAD SIGN BRIDGE
 - PROPOSED 4" STEEL CONDUIT
 - PROPOSED CONDUIT MARKER
 - PROPOSED TRANSIT AND TRAFFIC GUIDE
 - PROPOSED TRANSIT AND TRAFFIC HAZARD BOX
 - PROPOSED TRANSIT AND TRAFFIC MANHOLE
 - PROPOSED GUARD RAIL W/ SCAM
 - GUARD RAIL TO BE INSTALLED UNDER ORIGINAL CONTRACT

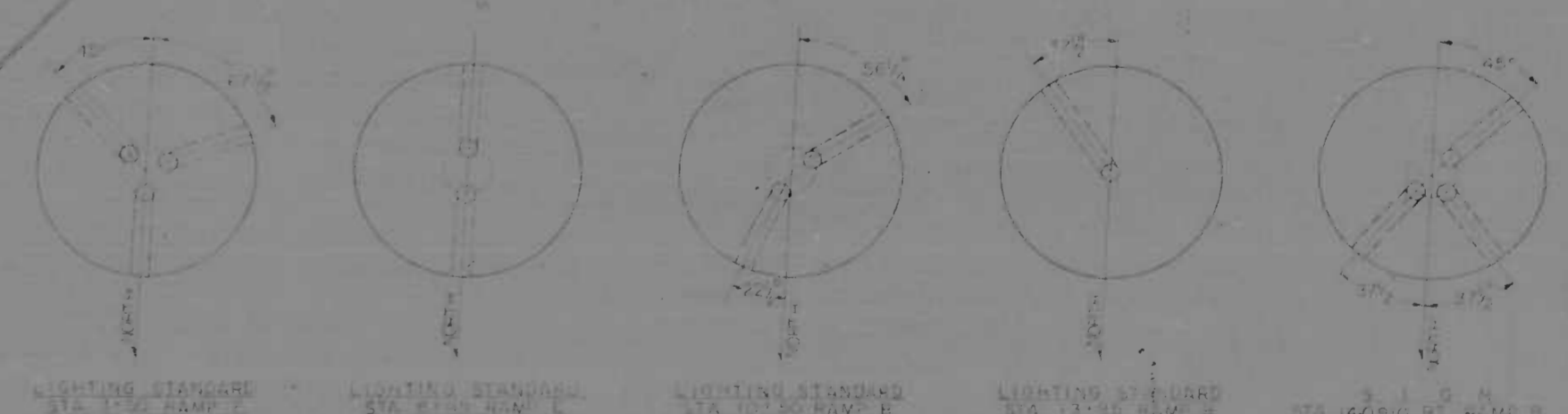

DETAILS - FOUNDATION CONDUIT ENTRANCES
1/8" = 1'-0"

REVISIONS Addition to Existing Contract 11-10-71	CONSULTANT KIMBLE, BENDER, STONE & ASSOC., INC. AND MATT CHILDS & ASSOC., INC. CONSULTING ENGINEERS 341 N. AVENUE STREET BALTIMORE, MARYLAND 21202	CITY OF BALTIMORE DEPARTMENT OF PUBLIC WORKS		STATE ROADS COMMISSION OF MARYLAND INTERSTATE DIVISION FOR BALTIMORE CITY	
		INTERSTATE ROUTE 95 PATTERNS AUTOMATIC INTERCHANGE		DRAWN BY TRACED BY T. J. M.	DES. BY CHP. BY
SCALE: 1" = 40'		DATE:		BALTO. CITY NO. 1973	

MATCH LINE 'A' SEE THIS SHEET

DATE	NO.	BY	REVISION
10-1-58	1	W.P.	ISSUED FOR CONSTRUCTION

MATCH LINE SEE SHEET NO 54

MATCH LINE SEE SHEET NO 56



NOTE:
 Replace Landing Headwall (90)
 Replace with Special B Headwall
 See Detail Sheet No. 20

LINE NO.	Δ	D	P	T	L	E	S	E
1	100.00	100.00	100.00	100.00	100.00	100.00	100.00	100.00
2	100.00	100.00	100.00	100.00	100.00	100.00	100.00	100.00
3	100.00	100.00	100.00	100.00	100.00	100.00	100.00	100.00
4	100.00	100.00	100.00	100.00	100.00	100.00	100.00	100.00
5	100.00	100.00	100.00	100.00	100.00	100.00	100.00	100.00

PAVEMENT LEGEND
 R Reinforced Concrete
 S Conventional Reinforced Concrete

BM 7732 Elev 86.032
 Bench Mark in West End of Survey
 West of Southeast Corner of Canton
 Street and Eastern Street 05'
 from West End of East Face

Right of Way Line
 This East 12' from East M 22 1/2' South
 of M 11. Revis. East M 22 1/2' South
 from Manhole as Located by Engineer

CROSS REFERENCE TABLE

ITEM	SHEET NO.
Profile - 1-95	50
Profile - Range B&E	50&47
Storm Sewer Profile	50&47
Sanitary Sewer Profile	50
Grading Plan - Ramps B&E	50&47
Manhole B Inlet Schedule	50
Data Details - Ramps B&E	50&47
Just Details	50&47

SANITARY SEWER MANHOLE SCHEDULE

NO.	LOCATION	COORDINATES	TYPE
5	Sta 10+12.18	2443.00 2275.00	512 MH
6	Sta 10+41.18	2422.00 2275.00	512 MH
7	See Plan	2411.00 2275.50	512 MH
8	Sta 14+26.16	2392.00 2270.00	512 MH
9	Sta 10+72.64	2374.00 2210.00	512 MH
10	Sta 17+20.15	2344.00 2307.00	512 MH



MATCH LINE 'W' SEE THIS SHEET

REVISIONS	CONSULTANT SANDRA WINGO, STONE & KESSE, INC.	CITY OF BALTIMORE DEPARTMENT OF PUBLIC WORKS	STATE ROADS COMMISSION OF MARYLAND INTERSTATE DIVISION FOR BALTIMORE CITY
	PAUL SPINER & ASSOC., INC. CONSULTING ENGINEERS 184 N. E. ST. BALTIMORE, MD.	INTERSTATE ROUTE 95 EASTERN AVENUE INTERCHANGE	DRAWN BY: A.P.P. CHECKED BY: W.J.P. DATE: 10-1-58
	SCALE: 1"=40'	DATE: 10-1-58	SHEET NO. 113

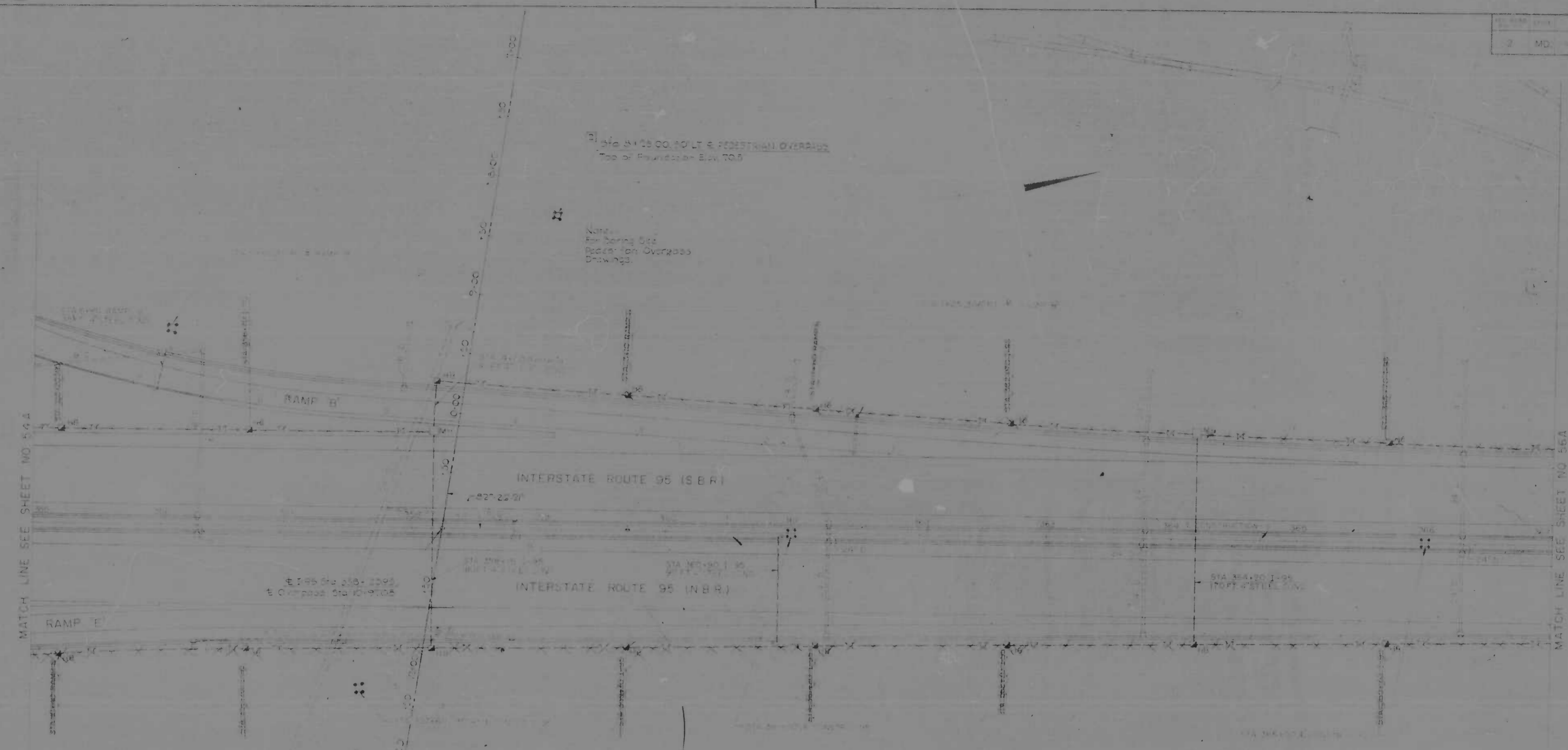

MATCH LINE SEE SHEET NO 54A

MATCH LINE SEE SHEET NO 56A

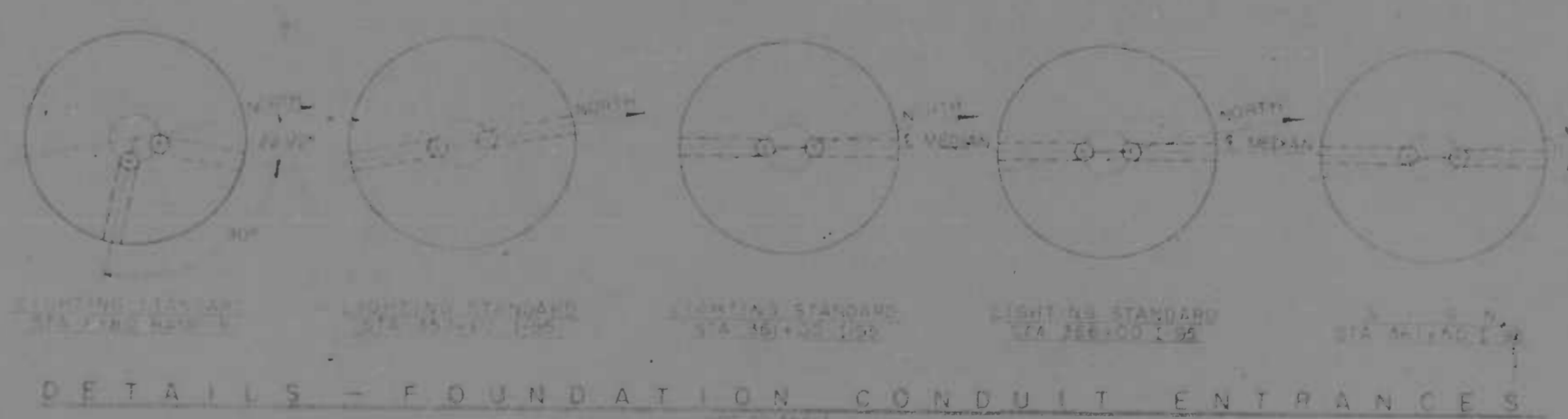

DETAILS - FOUNDATION CONDUIT ENTRANCES

LEGEND

- ⊕ PROPOSED FOUNDATION FOR HIGH MOUNT LIGHT STANDARDS
- ⊕ PROPOSED FOUNDATION FOR CONDUIT ENTRIES
- ⊕ PROPOSED FOUNDATION FOR OVERPASS STRUCTURES
- PROPOSED STEEL GIRL
- PROPOSED GUY WIRE
- PROPOSED TRAVEL AND TRAFFIC DUCT
- PROPOSED TRAVEL AND TRAFFIC DUCT
- PROPOSED TRAVEL AND TRAFFIC DUCT

QUINTON ST

1.25 Pedestrian Overpass
STA 3+00

REVISIONS Adding to Existing Contract H 10011 Single Foundation ASSN 51072	CONSULTANT EVERETT HUNTER LYNN & ASSOC. INC. MATT CHRIS & ASSOC. INC. CONSULTING ENGINEERS 140 N. CALVERT STREET BALTIMORE, MARYLAND 21202	CITY OF BALTIMORE DEPARTMENT OF PUBLIC WORKS 8 INTERSTATE WORKS DIV. FEDERAL AVENUE INTERCHANGE SCALE DATE	STATE ROADS COMMISSION OF MARYLAND INTERSTATE DIVISION FOR BALTIMORE CITY	
			DRAWN BY J. B. BELL CHECKED BY J. B. BELL DATE	SHEET NO. 554 OF 115

2	MD	1-85-42276	19	17
---	----	------------	----	----

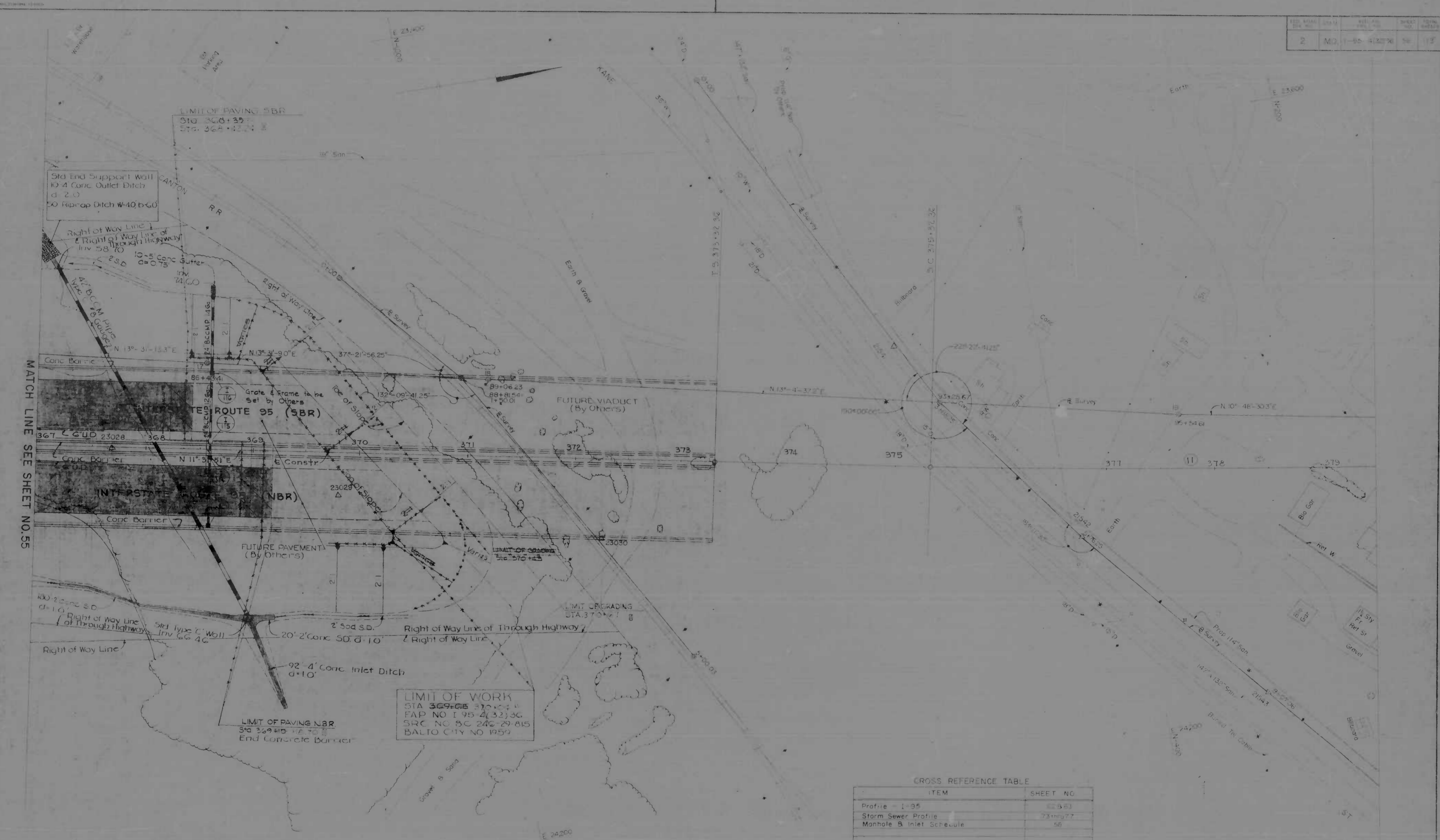

MATCH LINE SEE SHEET NO. 55

LIMIT OF WORK
 STA 369+05 TO 370+04
 FAP NO I 95-4(32)3C
 SRC NO 8C 246-29-815
 BALTO CITY NO 1959

LIMIT OF PAVING NBR
 STA 369+05 TO 370+04
 End Concrete Barrier

CROSS REFERENCE TABLE

ITEM	SHEET NO.
Profile 1-95	22 B 93
Storm Sewer Profile	731113 77
Manhole & Inlet Schedule	58

PAVEMENT LEGEND

8" Continuous Reinforced Cement Concrete

9" Conventional Reinforced Cement Concrete

IDENT	CURVE NO.	Δ	D	Ls	Ts	Lc	Rc	Os	Es	SE			
1-95	11	257.44	30'	0'	30'	20000	278.29	146.48	331.14	59.16	0.73000	295.48	-0.0167%

REVISIONS 1. Proposed Right of Way Line 4-27-70	CONSULTANT KNOERLE, BENDER, STONE & ASSOC., INC. AND HATZ, CHILDS & ASSOC., INC. CONSULTING ENGINEERS 141 N. CALVERT STREET BALTIMORE, MARYLAND 21202	CITY OF BALTIMORE DEPARTMENT OF PUBLIC WORKS & INTERSTATE ROUTE 95 EASTERN AVENUE INTERCHANGE	STATE ROADS COMMISSION OF MARYLAND INTERSTATE DIVISION FOR BALTIMORE CITY	
			DRAWN BY: W.E.P. TRACED BY: H.F.D. F.A.P. NO. 1-95-4(32)3C S.R.C. NO. 8C 246-29-815 BALTO CITY NO. 1959	DES. BY: G.C. CHK. BY: G.E.S. SHEET NO. 19 of 112
SCALE: 1"=40'		DATE: 4-27-70		

NO. ROAD DIST. NO.	NO. DIST. NO.	SHEET NO.	TOTAL SHEETS
2	MD	1-95-152136	56A 113



TRANSIT AND TRAFFIC CROSSOVER AT STA 332+00 I-95
OTHER CROSSINGS SIMILAR
NOT TO SCALE

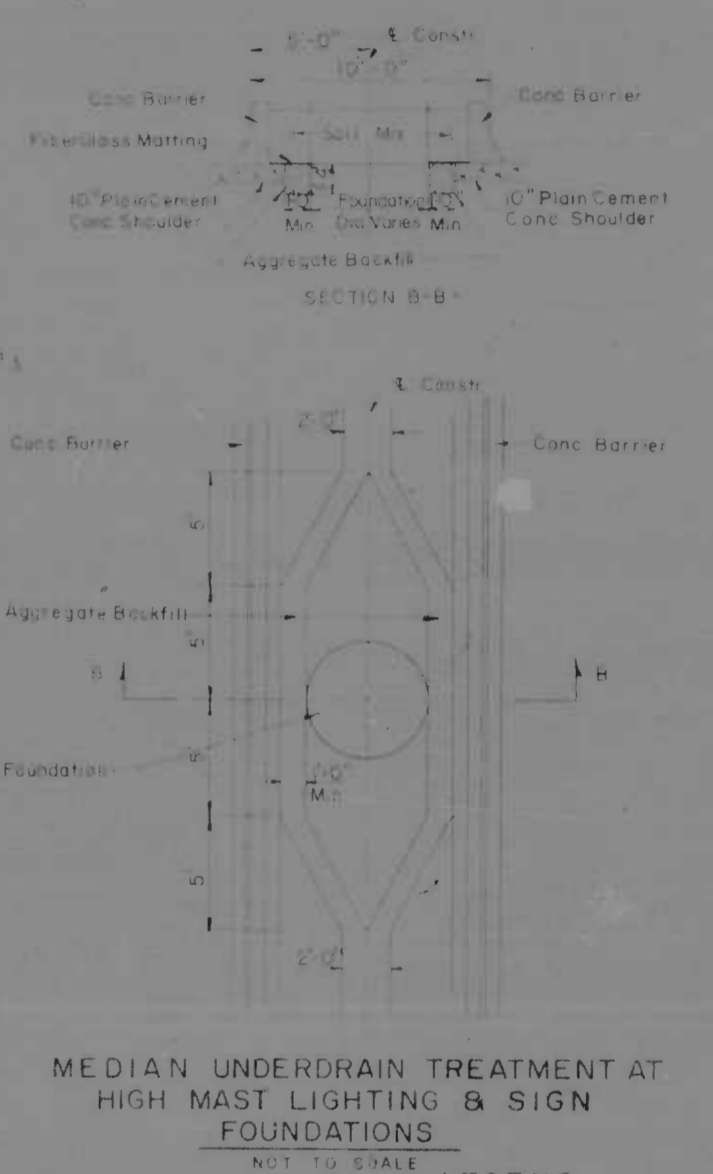
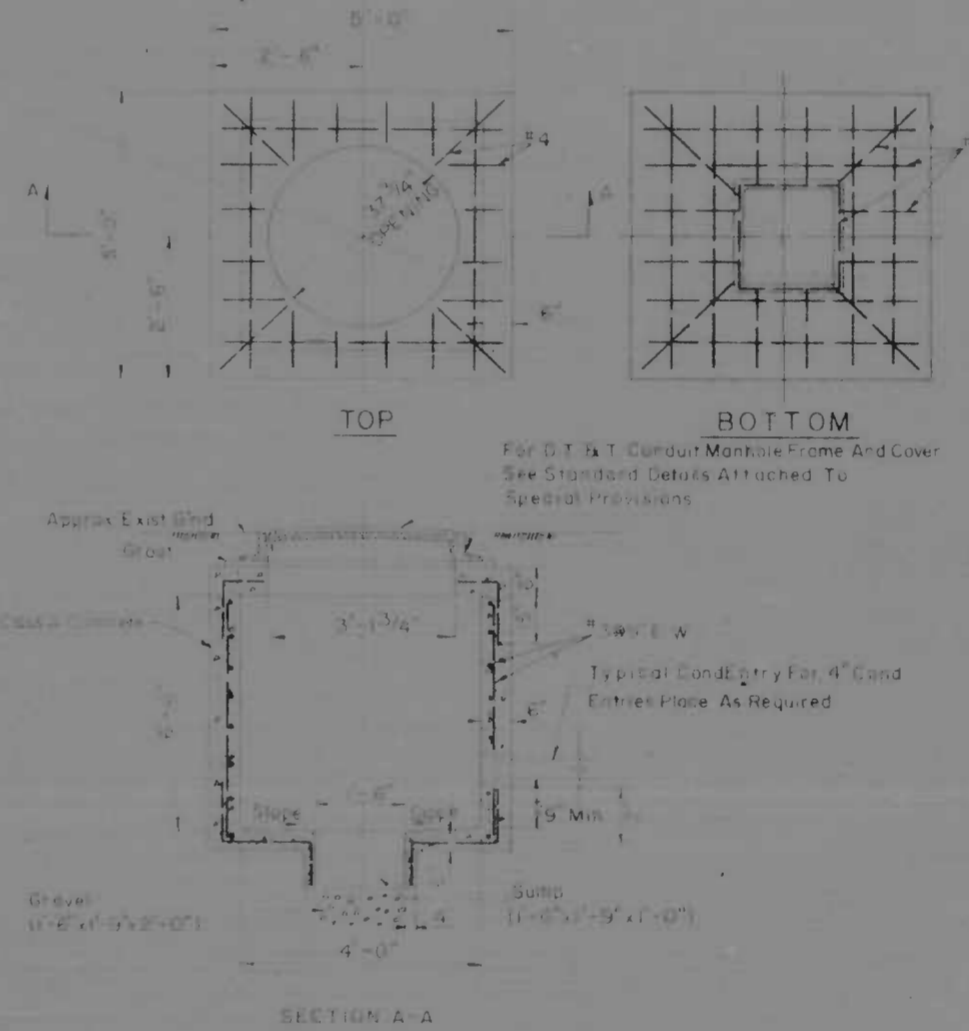

- LEGEND**
- PROPOSED FOUNDATION FOR HIGH MAST LIGHT STANDARD
 - PROPOSED FOUNDATION FOR GANTRY SIGN
 - PROPOSED FOUNDATIONS FOR OVERHEAD SIGN BRIDGE
 - PROPOSED 4" STEEL CONDUIT
 - PROPOSED CONDUIT MARKER
 - PROPOSED TRANSIT AND TRAFFIC DUCT
 - PROPOSED TRANSIT AND TRAFFIC HOUSING BOX
 - PROPOSED TRANSIT AND TRAFFIC MANHOLE

MATCH LINE SEE SHEET NO 55A

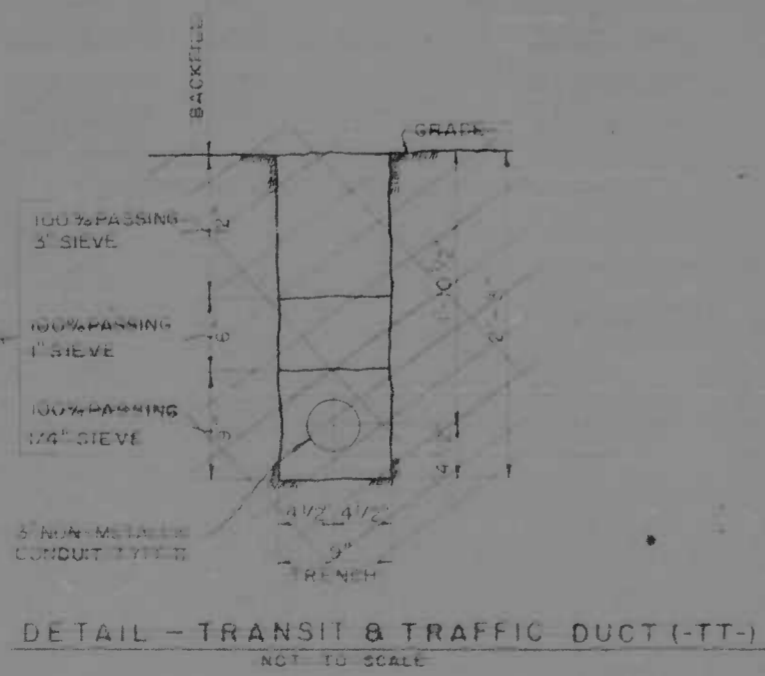

REVISIONS Addition to Existing Contract (1-11-97)	CONSULTANT KROENIG, BENDER, STONE & ASSOC., INC. WATZ, CHMDS & ASSOC., INC. CONSULTING ENGINEERS 341 A, L. ST. N.W. BETHESDA, MARYLAND 20814	CITY OF BALTIMORE DEPARTMENT OF PUBLIC WORKS INTERSTATE ROUTE 95 EASTERN AVENUE INTERCHANGE SCALE: 1" = 40' DATE:	STATE ROADS COMMISSION OF MARYLAND INTERSTATE DIVISION FOR BALTIMORE CITY	
			DRAWN BY: [Signature] P&E NO: 1-95-152136 S&C NO: DC-P&E-78-00 BALD CITY, MD	DES. BY: [Signature] SHEET NO: 56A TOTAL SHEETS: 113

NOTE
 Low Q. ANTI 2.5' to 4.0' to be
 2.5' in Service Before Existing
 Fire Hydrant 2.5' to 4.0' to be
 Taken Out of Service
 See Special Provisions



No.	EASTERN AVE DETOUR ROAD		CURVE DATA				
	Δ	Dc	R	T	L	E	SE
ED-1	38°-12'-42.5"	1°-56'-12"	490.00'	166.27'	320.12'	27.98'	
ED-2	38°-12'-42.5"	1°-56'-12"	400.00'	166.27'	320.12'	27.98'	+0.06%
ED-3	55°-06'-52.0"	23°-52'-24"	240.00'	125.33'	231.00'	30.75'	+0.06%
ED-4	55°-06'-52.0"	23°-52'-24"	240.00'	125.33'	231.00'	30.75'	

NOTE: Madison Island to be Removed and Temporary Pavement Placed Before Detour Road is Placed in Operation.

NOTE: Canton RR Spur shall remain in operation. See Special Provisions.

NOTE: For Sanitary and Storm Sewer Relocations, See Sheet No 52.

NOTE: For Paving Detail at Canton R.R. See Sheet No. 44.

NOTE: For Signalization Detail at Canton R.R. See Sheet No. 43.

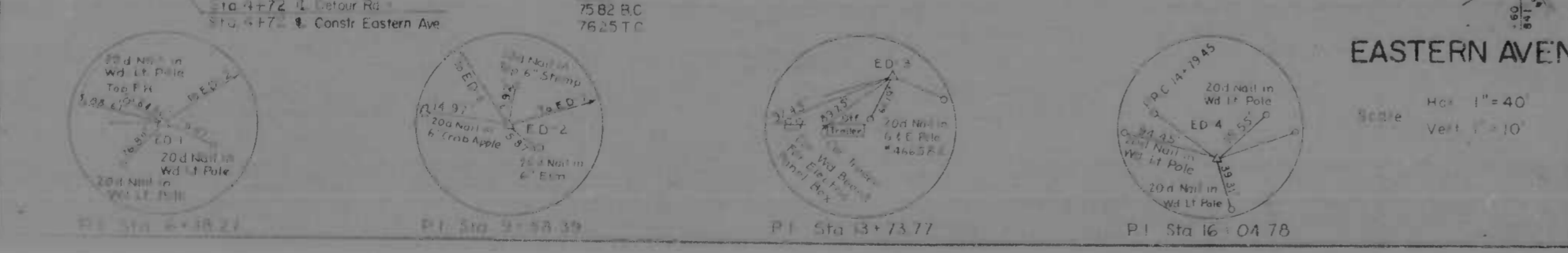
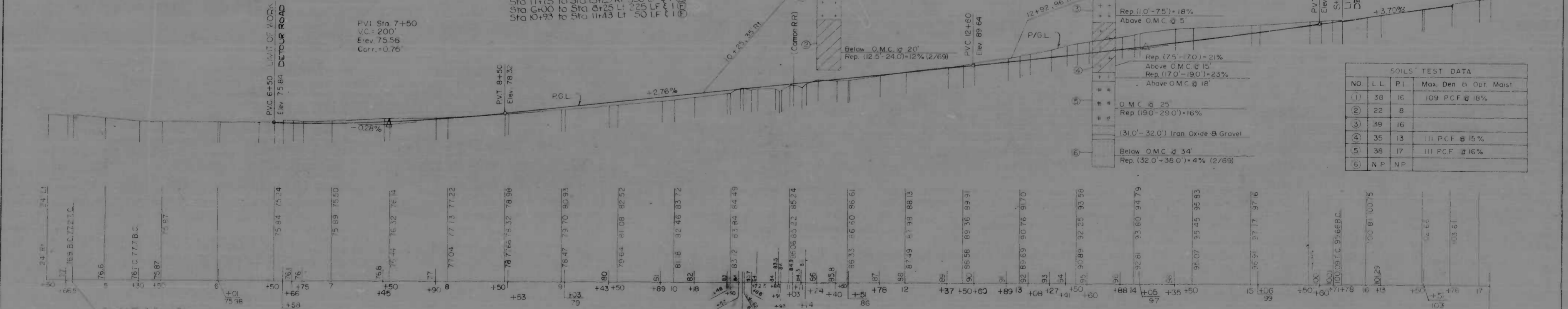

NO.	DATE	DESCRIPTION
1	10-6-69	AS SHOWN

REVISIONS

CONSULTANT: EMERLE, BENDER, STORKE & ASSOC., INC.

CONTRACTOR: MATZ, CARLOS & ASSOC., INC.

CITY OF BALTIMORE DEPARTMENT OF PUBLIC WORKS

STATE ROADS COMMISSION OF MARYLAND INTERSTATE DIVISION FOR BALTIMORE CITY

INTERSTATE ROUTE 95 EASTERN AVENUE INTERCHANGE

SCALE: 1" = 40'

DATE: 10-6-69

DRAWN BY: W.F.F. DES BY: D.E.B.

TRACED BY: E.P.D. CHK. BY: V.F.C.

F.A.P. NO. 1-95-4-32-136

S.R.C. NO. 80-246-29-B15

BALTO. CITY NO. 1959

SHEET NO. 57 OF 113

INLET AND STORM DRAIN MANHOLE SCHEDULE

SHEET NO. 58 OF 113
 PROJECT NO. MD 1-95-432136

INLET SCHEDULE						
NO	TYPE	LOCATION	CROSS SLOPE	TOP	INV. OUT.	REMARKS
1	Std. 15" Comb.	"F" Spout 23' Rt. 1+33		88.68	63.20	By Others
2	Std. 15" Comb.	E. Ave. 29' Rt. 1+07	0218	89.30	81.86	
3	Std. 15" Comb.	E. Ave. 39' Rt. 1+72	0231	86.20	80.06	
4	Std. 15" Comb.	E. Ave. 27' Lt. 4+70	0208	77.40	70.14	
5	Std. 15" Comb.	E. Ave. 29' Lt. 5+78	0208	76.20	72.02	
6	Std. 15" Comb.	E. Ave. 40' Rt. 5+67	0208	76.50	69.39	
7	Std. 15" Comb.	E. Ave. 40' Rt. 6+15	0208	76.80	68.58	
8	Std. 15" Comb.	E. Ave. 28' Lt. 6+72	0208	77.61	65.54	
9	Std. 15" Comb.	E. Ave. 77' Lt. 6+80		69.75	66.25	Single Grate
10	Std. 15" Comb.	E. Ave. 42' Rt. 8+25	0208	77.50	73.71	
11	Std. 15" Comb.	E. Ave. 42' Rt. 8+40	0208	77.60	73.80	
12	Std. 15" Comb.	E. Ave. 42' Lt. 9+55	0208	81.48	77.40	
13	Std. 15" Comb.	E. Ave. 42' Rt. 12+00	0208	92.36	88.55	
14	Std. 15" Comb.	E. Ave. 42' Lt. 12+84	0208	93.37	89.48	
15	Std. 15" Comb.	E. Ave. 42' Lt. 13+64	0208	96.01	85.01	
16	Std. 15" Comb.	E. Ave. 35' Rt. 13+65	0208	96.28	92.78	
17	Std. 15" Comb.	E. Ave. 33' Rt. 14+85	0208	100.81	93.49	
18	Std. 15" Comb.	"D" Spout 1.5' Lt. 23+90	0660	101.38	96.19	
19	Std. 15" Comb.	E. Ave. 35' Lt. 16+79	0208	106.86	103.19	
20	Std. 15" Comb.	"A" 25' Lt. 1+70		84.00	87.90	Single Grate
21	Std. 15" Comb.	"D" 55' Rt. 20+33		96.40	92.90	Single Grate
22	Mod. 15" Comb.	I-95 6.5' Rt. 329+80	0600	74.24	68.74	
23	Mod. 15" Comb.	"F" 25.5' Rt. 8+85	0600	68.92	65.42	
24	Std. 15" Comb.	I-95 175' Rt. 331+50		42.50	37.30	
25	Mod. 15" Comb.	I-95 6.5' Rt. 331+40	0600	70.05	64.55	
26	Mod. 15" Comb.	"F" 26' Rt. 7+30	0600	64.52	61.02	
27	Std. 15" Comb.	"F" 21' Rt. 5+35	1000	62.73	58.65	
28	Std. 15" Comb.	"F" 21' Rt. 5+45	1000	62.29	58.79	
29	Mod. 15" Comb.	I-95 6.5' Rt. 333+00	0600	66.16	60.66	
30	Mod. 15" Comb.	I-95 75.5' Lt. 333+80	0600	60.60	57.10	
31	Mod. 15" Comb.	I-95 6.5' Rt. 334+60	0600	62.87	57.37	
32	Std. 15" Comb.	I-95 195' Rt. 333+18	0400	48.80	41.40	
33	Std. 15" Comb.	I-95 200' Rt. 333+95	0160	50.00	46.36	
34	Std. 15" Comb.	I-95 245' Rt. 334+20	0308	52.00	48.50	
35	Mod. 15" Comb.	I-95 78.5' Lt. 335+55	0600	57.23	53.73	
36	Mod. 15" Comb.	I-95 6.5' Rt. 336+15	0600	60.20	54.70	
37	Mod. 15" Comb.	I-95 82' Lt. 337+28	0600	54.74	51.24	
38	Mod. 15" Comb.	I-95 6.5' Rt. 337+75	0600	58.60	52.66	
39	Std. 15" Comb.	I-95 132' Lt. 338+11		59.76	56.20	
40	Mod. 15" Comb.	I-95 85.5' Lt. 339+00	0600	53.62	50.02	
41	Mod. 15" Comb.	I-95 85.5' Lt. 339+10	0600	53.62	50.12	
42	Mod. 15" Comb.	I-95 6.5' Rt. 339+35	0600	57.54	54.04	
43	Std. 15" Comb.	I-95 95.5' Lt. 339+50		54.80	50.20	Single Grate
44	Std. 15" Comb.	I-95 98' Lt. 341+00		55.60	52.10	Single Grate
45	Mod. 15" Comb.	I-95 6.5' Rt. 341+35	0600	56.90	52.90	
46	Mod. 15" Comb.	I-95 6.5' Rt. 341+45	0600	56.90	53.40	
47	Mod. 15" Comb.	I-95 90.5' Lt. 341+65	0600	54.59	50.32	
48	Mod. 15" Comb.	I-95 6.5' Lt. 341+75	0088	57.50	53.50	
49	Mod. 15" Comb.	I-95 6.5' Rt. 343+80	0600	57.72	52.54	
50	Mod. 15" Comb.	I-95 6.5' Lt. 343+80	0340	58.02	54.52	
51	Mod. 15" Comb.	"C" 25.5' Rt. 13+20	0600	57.16	53.66	
52	Std. 15" Comb.	"C" 34.5' Rt. 12+30		58.44	54.94	Single Grate
53	Mod. 15" Comb.	"D" 34.5' Rt. 11+90	0600	63.57	58.48	
54	Mod. 15" Comb.	"D" 34.5' Rt. 12+00	0600	63.52	59.45	
55	Mod. 15" Comb.	"D" 23' Rt. 13+28	0600	64.24	59.49	
56	Std. 15" Comb.	"D" 53.5' Rt. 14+25		64.65	61.10	
57	Std. 15" Comb.	"D" 0.5' Rt. 17+38	0409	81.96	77.32	
58	Std. 15" Comb.	"D" 0.5' Rt. 18+15	0701	85.71	81.85	
59	Std. 15" Comb.	"D" 0.5' Rt. 19+10	0700	91.58	88.08	
60	Std. 15" Comb.	"A" 20' Lt. 8+80		57.00	52.30	
61	Std. 15" Comb.	"A" 21' Rt. 9+00	0827	56.70	52.26	
62	Std. 15" Comb.	"A" 35' Rt. 8+02		56.30	52.80	
63	Std. 15" Comb.	"A" 39' Rt. 9+00		57.30	53.30	Single Grate

INLET SCHEDULE						
NO	TYPE	LOCATION	CROSS SLOPE	TOP	INV. OUT.	REMARKS
64	Mod. 15" Comb.	"A" 28' Rt. 9+70	0600	59.00	54.50	
65	Std. 15" Comb.	"C" 23' Rt. 7+80	1000	62.08	58.28	
66	Std. 15" Comb.	"C" 13' Lt. 7+30		63.30	59.80	
67	Std. 15" Comb.	"C" 22.5' Lt. 9+63		60.40	54.40	
68	Std. 15" Comb.	"C" 35' Rt. 9+90		58.83	55.13	
69	Mod. 15" Comb.	"D" 29' Rt. 10+60	0600	58.12	54.62	
70	Std. 15" Comb.	"B" 15' Rt. 10+50	0600	89.70	86.20	
71	Std. 15" Comb.	"B" 49' Rt. 18+87		70.46	66.96	
72	Std. 15" Comb.	"B" 1.5' Rt. 19+87	0600	69.39	65.79	
73	Std. 15" Comb.	"B" 1.5' Rt. 19+00	0600	69.95	65.03	
74	Std. 15" Comb.	"B" 1.5' Rt. 13+50	0247	71.45	67.50	
75	Mod. 15" Comb.	"B" 25.5' Rt. 4+85	0600	81.30	77.80	
76	Mod. 15" Comb.	"B" 25.5' Rt. 1+78	0600	88.38	81.07	
77	Std. 15" Comb.	"E" 35' Rt. 3+25		85.00	81.50	Single Grate
78	Std. 15" Comb.	"E" 21' Rt. 4+85	7659	76.75	73.25	
79	Std. 15" Comb.	"E" 15.5' Rt. 7+10	1833	71.94	68.04	
80	Std. 15" Comb.	"E" 31' Rt. 7+25		70.50	67.00	Single Grate
81	Mod. 15" Comb.	"E" 26' Rt. 7+75	0600	70.34	67.04	
82	Mod. 15" Comb.	"E" 25.5' Rt. 8+40	0600	70.89	67.39	
83	Mod. 15" Comb.	"E" 25.5' Rt. 9+15	0600	72.24	68.74	
84	Mod. 15" Comb.	"E" 25.5' Rt. 11+50	0600	77.74	74.24	
85	Mod. 15" Comb.	I-95 6.5' Rt. 346+30	0600	60.21	56.71	
86	Mod. 15" Comb.	I-95 6.5' Lt. 346+30	0600	60.21	56.51	
87	Mod. 15" Comb.	"A" 25.5' Rt. 12+00	0600	59.70	56.41	
88	Std. 15" Comb.	I-95 102' Rt. 348+05		63.40	59.90	Single Grate
89	Mod. 15" Comb.	I-95 6.5' Rt. 348+85	0600	64.15	60.65	
90	Mod. 15" Comb.	I-95 6.5' Lt. 348+85	0600	64.19	59.19	
91	Mod. 15" Comb.	I-95 94' Rt. 349+12	0600	84.73	58.99	
92	Mod. 15" Comb.	I-95 6.5' Rt. 351+30	0600	68.46	64.96	
93	Mod. 15" Comb.	I-95 6.5' Lt. 351+30	0600	68.46	63.46	
94	Mod. 15" Comb.	I-95 84.5' Rt. 352+25	0200	70.63	67.13	
95	Mod. 15" Comb.	I-95 6.5' Rt. 353+80	0600	73.32	69.82	
96	Mod. 15" Comb.	I-95 6.5' Lt. 353+80	0600	73.32	68.91	
97	Mod. 15" Comb.	I-95 6.5' Rt. 356+30	0600	78.20	74.70	
98	Mod. 15" Comb.	I-95 6.5' Lt. 356+30	0600	78.20	73.89	
99	Std. 15" Comb.	I-95 127' Rt. 357+50		75.00	71.50	
100	Mod. 15" Comb.	I-95 6.5' Rt. 358+80	0600	84.00	80.50	
101	Mod. 15" Comb.	I-95 6.5' Lt. 358+80	0600	84.00	80.00	
102	Mod. 15" Comb.	I-95 91.5' Rt. 358+80	0600	83.56	80.06	
103	Mod. 15" Comb.	I-95 6.5' Rt. 361+30	0600	89.56	86.06	
104	Mod. 15" Comb.	I-95 6.5' Lt. 361+30	0600	89.55	82.41	
105	Mod. 15" Comb.	I-95 86.5' Rt. 361+30	0600	89.37	83.87	
106	Mod. 15" Comb.	I-95 6.5' Rt. 363+80	0600	95.34	89.05	
107	Mod. 15" Comb.	I-95 6.5' Lt. 363+80	0600	95.38	87.66	
108	Mod. 15" Comb.	I-95 84' Lt. 363+80	0600	98.17	86.86	
109	Mod. 15" Comb.	I-95 82' Rt. 363+80	0600	94.25	89.05	
110	Mod. 15" Comb.	I-95 6.5' Rt. 366+30	0600	100.89	94.87	
111	Mod. 15" Comb.	I-95 6.5' Lt. 366+30	0600	100.89	94.59	
112	Mod. 15" Comb.	I-95 76' Lt. 366+30	0600	100.86	93.77	
113	Mod. 15" Comb.	I-95 76.5' Rt. 366+30	0600	100.87	95.67	
114	Mod. 15" Comb.	I-95 6.5' Rt. 368+60	0600	104.58	98.18	
115	Mod. 15" Comb.	I-95 6.5' Lt. 368+60	0600	104.55	97.91	
116	Mod. 15" Comb.	I-95 78.5' Lt. 368+60	0600	104.55	96.11	Frame & Grate To Be Set By Others
117	Mod. 15" Comb.	I-95 78.5' Rt. 368+60	0600	104.55	96.35	
118	Std. 15" Comb.	I-95 289' Rt. 329+96		41.80	34.40	Single Grate

STORM DRAIN MANHOLE SCHEDULE						
NO	TYPE	LOCATION	COORDINATES		REMARKS	
			NORTH	EAST		
1	Std. S.W.M.H.	E. Ave. 28' Lt. 5+84	3479.66	22765.11	Std. M.H. Chan. No. 6	
2	Std. Drop M.H.	E. Ave. 44' Rt. 13+74	3509.94	23587.73	Std. M.H. Chan. No. 11	
3	Std. Drop M.H.	E. Ave. 60' Lt. 14+00.48	3515.90	23614.90	11.97' Drop	
4	Std. S.W.M.H.	E. Ave. 44' Rt. 16+97	3422.67	23866.86	Std. M.H. Chan. No. 7	
5	Std. S.W.M.H.	"A" 54' Lt. 7+70.19	3803.75	23458.40	Std. M.H. Chan. No. 11	
6	Std. S.W.M.H.	I-95 13' Lt. 330+15.47	4184.54	23268.26	Bellefonte	
7	Std. S.W.M.H.	I-95 175' Rt. 335+88.26	4502.60	23114.26	Bellefonte	
8	Std. S.W.M.H.	I-95 179' Rt. 333+98.36	4664.00	23066.00	Std. M.H. Chan. No. 11	
9	Std. S.W.M.H.	I-95 210' Lt. 331+73.58	4685.56	22621.27	Bellefonte	
10	Std. S.W.M.H.	I-95 98' Lt. 330+70.99	4275.32	22954.18	Bellefonte	
11	Std. S.W.M.H.	I-95 100' Lt. 340+85.22	3923.00	23105.33	Std. M.H. Chan. No. 11	
12	Std. S.W.M.H.	"A" 39' Rt. 9+49.64	3673.13	23410.33	Std. M.H. Chan. No. 11	
13	Std. S.W.M.H.	I-95 104' Lt. 344+94.75	3532.88	23192.56	Std. M.H. Chan. No. 11	
14	Std. S.W.M.H.	I-95 138' Lt. 347+93.67	3582.88	23430.81	Std. M.H. Chan. No. 11	
15	Std. Drop M.H.	I-95 106' Lt. 348+89.87	3145.40	23269.87	3.0' Drop	
16	Std. Drop M.H.	I-95 97' Lt. 351+95.08	3887.05	23530.40		
17	Std. S.W.M.H.	I-95 111' Lt. 352+90.08	2752.34	23548.23	Std. M.H. Chan. No. 11	
18	Std. S.W.M.H.	I-95 147' Lt. 356+33.00	2409.20	23378.86		
19	Std. Drop M.H.	I-95 205' Lt. 357+13.95	2403.29	23739.90	1.96' Drop	
20	Std. S.W.M.H.	I-95 399' Lt. 365+61.08	1473.44	23311.93	Std. M.H. Chan. No. 7	
21	Std. Drop M.H.	"E" 14' Lt. 7+40.00	3082.70	23114.06		
22	Std. Drop M.H.	"E" 35' Lt. 3+39.00	3244.43	23582.47		
23	Std. S.W.M.H.	"E" 39' Lt. 7+15.00	2384.20	23577.61		

LEGEND

Mod. 15" Comb. - Modified Type 15" Comb. Inlet - Double Grate
 Std. 15" Comb. - Standard Type 15" Comb. Inlet - Double Grate
 Std. 15" - Standard Type 15" Inlet - Double Grate
 Std. 15" - Standard Type 15" Inlet - Double Grate

REVISIONS	CONSULTANT	CITY OF BALTIMORE	STATE ROADS COMMISSION OF MARYLAND
	KROEHL, BENDER, STONE & ASSOC., INC.	DEPARTMENT OF PUBLIC WORKS	INTERSTATE DIVISION FOR BALTIMORE CITY
	MATZ, CHILDS & ASSOC., INC.	INTERSTATE ROUTE 95	DRAWN BY: ACB
	CONSULTING ENGINEERS	EASTERN AVENUE INTERCHANGE	DES. BY: WFF
	141 N. CALVERT STREET		TRACED BY: ACB
	BALTIMORE, MARYLAND 21202		CHK. BY: DES
		SCALE: 1" = 20'	F.A.P. NO. 1-95-4132136
		DATE: 6-2-70	S.R.C. NO. BC 246-29-815
			SHEET NO. 58 OF 113

STORM DRAIN SCHEDULE

FILE NO.	STATE	JOB NO.	SHEET NO.	TOTAL SHEETS
2	MD	1-95-4132136	59	113

SHEET NO. 50

Constr. Sta. 329+80 Rt.
160'-18" R.C. Pipe Class IV
1-Mod. 'S' Comb. Inlet Dbl. Grate

Constr. Sta. 329+90 Rt.
66'-18" R.C. Pipe Class IV
1-Std. 'K' Inlet Single Grate
1-60"x18" Collar Tap

Constr. Sta. 331+04 to Sta. 333+98 Rt.
304'-60" R.C. Pipe Class IV
1-60"x42" Bellmouth

Constr. Sta. 331+40 Rt.
88'-18" R.C. Pipe Class IV
1-Mod. 'S' Comb. Inlet Dbl. Grate
1-42"x18" Brick Y

Constr. Sta. 331+50 Rt.
12'-18" R.C. Pipe Class IV
1-Std. Inlet Dbl. Grate
1-42"x18" Brick Y

Constr. Sta. 332+50 Rt. & Lt.
404'-42" R.C. Pipe Class V
1-Std. Type 'C' Endwall for 42" Pipe

Constr. Sta. 333+00 Rt.
160'-24" B.C.C.M. Pipe Type 'C' #14 Gauge
1-Mod. 'S' Comb. Inlet Dbl. Grate
1-End Sect. for 24" C.M. Pipe

Constr. Sta. 7+25 Ramp 'F' Rt.
64'-18" R.C. Pipe Class IV
1-Mod. 'S' Comb. Inlet Dbl. Grate
1-End Sect. for 18" C.M. Pipe

Constr. Sta. 8+85 Ramp 'F' Rt.
64'-18" B.C.C.M. Pipe Type 'C' #14 Gauge
1-Mod. 'S' Comb. Inlet Dbl. Grate
1-End Sect. for 18" C.M. Pipe

Constr. Sta. 336+53 Rt. & Lt.
208'-54" R.C. Pipe Class IV
1-54"x18"x48" Bellmouth with Manhole

Constr. Sta. 336+52 Lt.
24'-48" R.C. Pipe Class IV
1-48" Pipe Conn. Brick Curve

Constr. Sta. 336+70 Lt.
76'-48" R.C. Pipe Class IV

Constr. Sta. 337+24 Rt.
212'-48" R.C. Pipe Class IV
1-48" Pipe Conn. Brick Curve

Constr. Sta. 337+28 Lt.
52'-18" R.C. Pipe Class IV
1-Mod. 'S' Comb. Inlet Dbl. Grate
1-48"x18" Collar Tap

Constr. Sta. 337+63 Lt.
296'-48" R.C. Pipe Class IV
1-48" Pipe Conn. Brick Curve

Constr. Sta. 337+75 Lt. & Rt.
88'-18" R.C. Pipe Class IV
1-Mod. 'S' Comb. Inlet Dbl. Grate
1-48"x18" Collar Tap

Constr. Sta. 338+10 Lt.
48'-21" R.C. Pipe Class IV
1-Std. 'K' Inlet Dbl. Grate
1-48"x21" Pipe Conn. Brick Y

Constr. Sta. 339+00 Lt.
16'-18" R.C. Pipe Class IV
2-Mod. 'S' Comb. Inlets Dbl. Grates
1-48"-18" Collar Tap

Constr. Sta. 339+15 Rt.
88'-48" R.C. Pipe Class IV
1-48"x48" Bellmouth with Manhole

Constr. Sta. 339+35 Rt.
116'-18" R.C. Pipe Class IV
1-Mod. 'S' Comb. Inlet Dbl. Grate
1-48"x18" Collar Tap

Constr. Sta. 339+35 99 Rt.
384'-36" R.C. Pipe Class IV
1-48"x36" Pipe Conn. Chang. Sect.
Brick Curve

Constr. Sta. 339+50 Lt.
8'-18" R.C. Pipe Class IV
1-Std. 'K' Inlet Single Grate
1-48"x18" Collar Tap

Constr. Sta. 340+07.56 Rt.
288'-48" R.C. Pipe Class IV
1-48" Pipe Conn. Brick Curve

Constr. Sta. 340+85 Lt.
400'-42" R.C. Pipe Class IV
1-Std. Storm Water Manhole 30" Cover

Constr. Sta. 341+00 Lt.
12'-18" B.C.C.M. Pipe Type 'C' #14 Gauge
1-Std. 'K' Inlet Single Grate

Constr. Sta. 341+35 Rt.
84'-18" R.C. Pipe Class IV
2-Mod. 'S' Comb. Inlets Dbl. Grates
1-48"x18" Collar Tap

Constr. Sta. 341+65 Lt.
12'-21" R.C. Pipe Class IV
1-Mod. 'S' Comb. Inlet Dbl. Grate
1-42"x21" Brick Y

Constr. Sta. 341+75 Lt.
84'-18" R.C. Pipe Class IV
1-Mod. 'S' Comb. Inlet Dbl. Grate

Constr. Sta. 8+45 Ramp 'F' Rt.
3'-18" B.C.C.M. Pipe Type 'C' #12 Gauge
2-Std. 'S' Comb. Inlets Dbl. Grates

Constr. Sta. 5+70 Rt. & Lt. Ramp 'F'
144'-24" R.C. Pipe Class IV
1-End Sects. for 24" R.C. Pipe
14'-2" Comb. Outlet Ditch 3'-3"

Constr. Sta. 11+90 Rt. Ramp 'D'
20'-18" R.C. Pipe Class IV
2-Mod. 'S' Comb. Inlets Dbl. Grates
1-48"x18" Collar Tap

Constr. Sta. 13+25 Rt. & Lt. Ramp 'D'
44'-18" R.C. Pipe Class IV
2-Mod. 'S' Comb. Inlet Dbl. Grate
1-48"x18" Collar Tap

Constr. Sta. 14+25 Rt. Ramp 'D'
100'-18" B.C.C.M. Pipe Type 'C' #14 Gauge
1-Std. 'K' Inlet Dbl. Grate

Constr. Sta. 12+20 Ramp 'A' Rt.
16'-18" B.C.C.M. Pipe Type 'C' #12 Gauge
1-36"x18" Pipe Conn. Brick Y
1-Mod. 'S' Comb. Inlet Dbl. Grate

Constr. Sta. 9+50 Ramp 'C' Rt.
40'-18" B.C.C.M. Pipe Type 'C' #14 Gauge
1-36"x18" Pipe Conn. Brick Y
1-Std. 'K' Inlet Dbl. Grate

Constr. Sta. 9+85 Ramp 'B' Lt. & Rt.
32'-18" B.C.C.M. Pipe Type 'C' #12 Gauge
1-36"x18" Pipe Conn. Brick Y
1-Std. 'K' Inlet Dbl. Grate

Constr. Sta. 10+60 Ramp 'C' Rt.
16'-18" B.C.C.M. Pipe Type 'C' #14 Gauge
1-36"x18" Pipe Conn. Brick Y
1-Mod. 'S' Comb. Inlet Dbl. Grate

Constr. Sta. 13+20 Ramp 'C' Rt.
12'-18" B.C.C.M. Pipe Type 'C' #14 Gauge
1-42"x18" Pipe Conn. Brick Y
1-Mod. 'S' Comb. Inlet Dbl. Grate

Constr. Sta. 17+35 Ramp 'D' Lt.
28'-18" B.C.C.M. Pipe Type 'C' #14 Gauge
1-Std. 'S' Inlet Dbl. Grate
1-End Section for 18" C.M. Pipe

Constr. Sta. 18+25 Ramp 'D' Lt.
80'-18" B.C.C.M. Pipe Type 'C' #12 Gauge
1-Std. 'S' Inlet Dbl. Grate

Constr. Sta. 19+10 Ramp 'D' Lt.
96'-18" B.C.C.M. Pipe Type 'C' #12 Gauge
1-Std. 'S' Inlet Dbl. Grate

Constr. Sta. 20+33 Ramp 'D' Rt.
188'-18" R.C. Pipe Class IV
1-Std. 'A' Inlet Single Grate

Constr. Sta. 8+25 Eastern Avenue Rt.
8'-18" R.C. Pipe Class IV
1-Std. 'S' Comb. Inlet Dbl. Grate

Constr. Sta. 8+40 Eastern Avenue Rt.
16'-18" R.C. Pipe Class IV
1-Std. Comb. Inlet Dbl. Grate

Constr. Sta. 9+55 Eastern Avenue Lt.
140'-15" R.C. Pipe Class IV
1-Std. 'S' Comb. Inlet Dbl. Grate
1-30"x15" Pipe Conn. Collar Tap

Constr. Sta. 12+60 Eastern Avenue Rt.
116'-18" R.C. Pipe Class IV
1-Std. 'S' Comb. Inlet Dbl. Grate

Constr. Sta. 12+84 Eastern Avenue Lt.
80'-18" R.C. Pipe Class IV
1-Std. 'S' Comb. Inlet Dbl. Grate

Constr. Sta. 13+70 Eastern Avenue Lt.
28'-18" R.C. Pipe Class IV
1-Std. 'S' Comb. Inlet Dbl. Grate

Constr. Sta. 13+74 Eastern Avenue Rt.
28'-18" R.C. Pipe Class IV
1-Std. 'S' Comb. Inlet Dbl. Grate

Constr. Sta. 14+00 Eastern Avenue Rt.
28'-18" R.C. Pipe Class IV
1-Std. Storm Water Manhole 24" Cover

Constr. Sta. 14+00 Eastern Avenue Rt.
12'-30" R.C. Pipe Class IV
1-Pipe Conn. Brick Curve

Constr. Sta. 14+85 Eastern Avenue Rt.
23'-18" R.C. Pipe Class IV
1-Std. 'S' Comb. Inlet Dbl. Grate

Constr. Sta. 15+40 Eastern Avenue Rt.
40'-18" R.C. Pipe Class IV
1-Std. 'S' Comb. Inlet Dbl. Grate

Constr. Sta. 16+79 Eastern Avenue Lt.
22'-18" R.C. Pipe Class IV
1-Std. 'S' Comb. Inlet Dbl. Grate
1-Std. Storm Water Manhole 24" Cover

SHEET NO. 51

Constr. Sta. 333+50 Lt.
48'-18" R.C. Pipe Class IV
1-Mod. 'S' Comb. Inlet Dbl. Grate
1-42"x18" Brick Y

Constr. Sta. 333+48 Rt.
16'-18" R.C. Pipe Class IV
1-Std. 'S' Comb. Inlet Dbl. Grate
1-60"x18" Collar Tap

Constr. Sta. 333+95 Rt.
20'-18" R.C. Pipe Class IV
1-Std. 'S' Comb. Inlet Dbl. Grate

Constr. Sta. 333+98 to Sta. 335+88 Rt.
216'-00" R.C. Pipe Class IV
1-Std. Storm Water Manhole, 30" Cover

Constr. Sta. 334+20 Rt.
48'-18" R.C. Pipe Class IV
1-Std. 'S' Comb. Inlet Dbl. Grate

Constr. Sta. 334+60 Rt.
152'-24" B.C.C.M. Pipe Type 'C' #12 Gauge
1-Mod. 'S' Comb. Inlet Dbl. Grate
1-End Section for 24" C.M. Pipe

Constr. Sta. 335+55 Lt.
110'-18" B.C.C.M. Pipe Type 'C' #14 Gauge
1-Mod. 'S' Comb. Inlet Dbl. Grate

Constr. Sta. 335+88 Rt.
38'-60" R.C. Pipe Class IV
1-60"x48" Pipe Conn. Chang. Section
Brick Curve

Constr. Sta. 335+88 Rt.
35'-54" R.C. Pipe Class IV
1-60"x48" Bellmouth with Manhole
1-64" Pipe Conn. Brick Curve

Constr. Sta. 336+13.73 Rt.
124'-48" R.C. Pipe Class IV

Constr. Sta. 336+40 Rt.
36'-18" R.C. Pipe Class IV
1-Mod. 'S' Comb. Inlet Dbl. Grate
1-54"x18" Collar Tap

Constr. Sta. 339+35 Rt.
116'-18" R.C. Pipe Class IV
1-Mod. 'S' Comb. Inlet Dbl. Grate
1-48"x18" Collar Tap

Constr. Sta. 339+35 99 Rt.
384'-36" R.C. Pipe Class IV
1-48"x36" Pipe Conn. Chang. Sect.
Brick Curve

Constr. Sta. 339+50 Lt.
8'-18" R.C. Pipe Class IV
1-Std. 'K' Inlet Single Grate
1-48"x18" Collar Tap

Constr. Sta. 340+07.56 Rt.
288'-48" R.C. Pipe Class IV
1-48" Pipe Conn. Brick Curve

Constr. Sta. 340+85 Lt.
400'-42" R.C. Pipe Class IV
1-Std. Storm Water Manhole 30" Cover

Constr. Sta. 341+00 Lt.
12'-18" B.C.C.M. Pipe Type 'C' #14 Gauge
1-Std. 'K' Inlet Single Grate

Constr. Sta. 341+35 Rt.
84'-18" R.C. Pipe Class IV
2-Mod. 'S' Comb. Inlets Dbl. Grates
1-48"x18" Collar Tap

Constr. Sta. 341+65 Lt.
12'-21" R.C. Pipe Class IV
1-Mod. 'S' Comb. Inlet Dbl. Grate
1-42"x21" Brick Y

Constr. Sta. 341+75 Lt.
84'-18" R.C. Pipe Class IV
1-Mod. 'S' Comb. Inlet Dbl. Grate

Constr. Sta. 8+45 Ramp 'F' Rt.
3'-18" B.C.C.M. Pipe Type 'C' #12 Gauge
2-Std. 'S' Comb. Inlets Dbl. Grates

Constr. Sta. 5+70 Rt. & Lt. Ramp 'F'
144'-24" R.C. Pipe Class IV
1-End Sects. for 24" R.C. Pipe
14'-2" Comb. Outlet Ditch 3'-3"

SHEET NO. 52

Constr. Sta. 343+15 Rt.
4'-18" R.C. Pipe Class IV
1-48"x18" Pipe Conn. Collar Tap
1-Std. 'K' Inlet Dbl. Grate

Constr. Sta. 343+50 Rt.
88'-48" R.C. Pipe Class IV
1-48" Pipe Conn. Brick Curve

Constr. Sta. 343+75 Rt.
16'-48" R.C. Pipe Class IV
1-48" Pipe Conn. Brick Curve

Constr. Sta. 343+80 Lt. & Rt.
132'-18" R.C. Pipe Class IV
1-48"x18" Pipe Conn. Brick Y
2-Mod. 'S' Comb. Inlets Dbl. Grates

Constr. Sta. 344+95 Lt.
100'-36" R.C. Pipe Class IV
1-Std. Storm Water Manhole 24" Cover

Constr. Sta. 345+35 Rt.
268'-36" R.C. Pipe Class IV
1-48" Pipe Conn. Brick Curve

Constr. Sta. 345+95 Lt.
104'-36" R.C. Pipe Class IV
1-36" Pipe Conn. Brick Curve

Constr. Sta. 346+20 Lt.
104'-18" R.C. Pipe Class IV
1-36"x18" Brick Y
1-Mod. 'S' Comb. Inlet Dbl. Grate

Constr. Sta. 346+30 Lt. & Rt.
16'-18" R.C. Pipe Class IV
1-Mod. 'S' Comb. Inlet Dbl. Grate

Constr. Sta. 347+00 Lt.
188'-36" R.C. Pipe Class IV
1-36" Pipe Conn. Brick Curve

Constr. 1+70 Ramp 'A' Lt.
44'-21" R.C. Pipe Class IV
1-Std. 'K' Inlet Single Grate

Constr. Sta. 7+70 Ramp 'A' Rt.
228'-30" R.C. Pipe Class IV
1-Std. Storm Water Manhole 24" Cover

Constr. Sta. 8+90 Ramp 'A' Rt.
24'-18" R.C. Pipe Class IV
1-48"x18" Pipe Conn. Collar Tap
1-Std. 'K' Inlet Dbl. Grate

Constr. Sta. 9+00 Ramp 'A' Rt.
4'-18" R.C. Pipe Class IV
1-48"x18" Pipe Conn. Collar Tap
1-Std. 'S' Comb. Inlet Dbl. Grate

Constr. Sta. 9+50 Ramp 'A' Rt.
52'-36" R.C. Pipe Class IV
1-Std. Storm Water Manhole 24" Cover

Constr. Sta. 9+80 Ramp 'A' Rt.
12'-18" B.C.C.M. Pipe Type 'C' #12 Gauge
1-Std. 'K' Inlet Single Grate

Constr. Sta. 9+70 Ramp 'A' Rt.
12'-18" B.C.C.M. Pipe Type 'C' #14 Gauge
1-Mod. 'S' Comb. Inlet Dbl. Grate
1-36"x18" Pipe Conn. Brick Y

Constr. Sta. 12+20 Ramp 'A' Rt.
16'-18" B.C.C.M. Pipe Type 'C' #12 Gauge
1-36"x18" Pipe Conn. Brick Y
1-Mod. 'S' Comb. Inlet Dbl. Grate

Constr. Sta. 9+50 Ramp 'C' Rt.
40'-18" B.C.C.M. Pipe Type 'C' #14 Gauge
1-36"x18" Pipe Conn. Brick Y
1-Std. 'K' Inlet Dbl. Grate

Constr. Sta. 9+85 Ramp 'B' Lt. & Rt.
32'-18" B.C.C.M. Pipe Type 'C' #12 Gauge
1-36"x18" Pipe Conn. Brick Y
1-Std. 'K' Inlet Dbl. Grate

Constr. Sta. 10+60 Ramp 'C' Rt.
16'-18" B.C.C.M. Pipe Type 'C' #14 Gauge
1-36"x18" Pipe Conn. Brick Y
1-Mod. 'S' Comb. Inlet Dbl. Grate

Constr. Sta. 13+20 Ramp 'C' Rt.
12'-18" B.C.C.M. Pipe Type 'C' #14 Gauge
1-42"x18" Pipe Conn. Brick Y
1-Mod. 'S' Comb. Inlet Dbl. Grate

Constr. Sta. 17+35 Ramp 'D' Lt.
28'-18" B.C.C.M. Pipe Type 'C' #14 Gauge
1-Std. 'S' Inlet Dbl. Grate
1-End Section for 18" C.M. Pipe

Constr. Sta. 18+25 Ramp 'D' Lt.
80'-18" B.C.C.M. Pipe Type 'C' #12 Gauge
1-Std. 'S' Inlet Dbl. Grate

Constr. Sta. 19+10 Ramp 'D' Lt.
96'-18" B.C.C.M. Pipe Type 'C' #12 Gauge
1-Std. 'S' Inlet Dbl. Grate

Constr. Sta. 20+33 Ramp 'D' Rt.
188'-18" R.C. Pipe Class IV
1-Std. 'A' Inlet Single Grate

Constr. Sta. 8+25 Eastern Avenue Rt.
8'-18" R.C. Pipe Class IV
1-Std. 'S' Comb. Inlet Dbl. Grate

Constr. Sta. 8+40 Eastern Avenue Rt.
16'-18" R.C. Pipe Class IV
1-Std. Comb. Inlet Dbl. Grate

Constr. Sta. 9+55 Eastern Avenue Lt.
140'-15" R.C. Pipe Class IV
1-Std. 'S' Comb. Inlet Dbl. Grate
1-30"x15" Pipe Conn. Collar Tap

Constr. Sta. 12+60 Eastern Avenue Rt.
116'-18" R.C. Pipe Class IV
1-Std. 'S' Comb. Inlet Dbl. Grate

Constr. Sta. 12+84 Eastern Avenue Lt.
80'-18" R.C. Pipe Class IV
1-Std. 'S' Comb. Inlet Dbl. Grate

Constr. Sta. 13+70 Eastern Avenue Lt.
28'-18" R.C. Pipe Class IV
1-Std. 'S' Comb. Inlet Dbl. Grate

Constr. Sta. 13+74 Eastern Avenue Rt.
28'-18" R.C. Pipe Class IV
1-Std. 'S' Comb. Inlet Dbl. Grate

Constr. Sta. 14+00 Eastern Avenue Rt.
28'-18" R.C. Pipe Class IV
1-Std. Storm Water Manhole 24" Cover

Constr. Sta. 14+00 Eastern Avenue Rt.
12'-30" R.C. Pipe Class IV
1-Pipe Conn. Brick Curve

Constr. Sta. 14+85 Eastern Avenue Rt.
23'-18" R.C. Pipe Class IV
1-Std. 'S' Comb. Inlet Dbl. Grate

Constr. Sta. 15+40 Eastern Avenue Rt.
40'-18" R.C. Pipe Class IV
1-Std. 'S' Comb. Inlet Dbl. Grate

Constr. Sta. 16+79 Eastern Avenue Lt.
22'-18" R.C. Pipe Class IV
1-Std. 'S' Comb. Inlet Dbl. Grate
1-Std. Storm Water Manhole 24" Cover

REVIEWS	CONSULTANT	CITY OF BALTIMORE DEPARTMENT OF PUBLIC WORKS &		STATE ROADS COMMISSION OF MARYLAND INTERSTATE DIVISION FOR BALTIMORE CITY	
	ENDRUE, BENOIR, SPONI & ASSOC., INC. AND MATZ, CHILDS & ASSOC., INC. CONSULTING ENGINEERS 241 N. CALVERT STREET BALTIMORE, MARYLAND 21202	INTERSTATE ROUTE 95 EASTERN AVENUE INTERCHANGE		DRAWN BY: W.F.F. R.K.	DES. BY: C.E.P. CHK. BY: J.G.C.
		SCALE	DATE: 6-3-70	SHEET NO. 59 OF 113	

PROJECT NO.	DATE	SCALE	SHEET NO.	TOTAL SHEETS
2	MD-95-4	SECTION 6	6	113

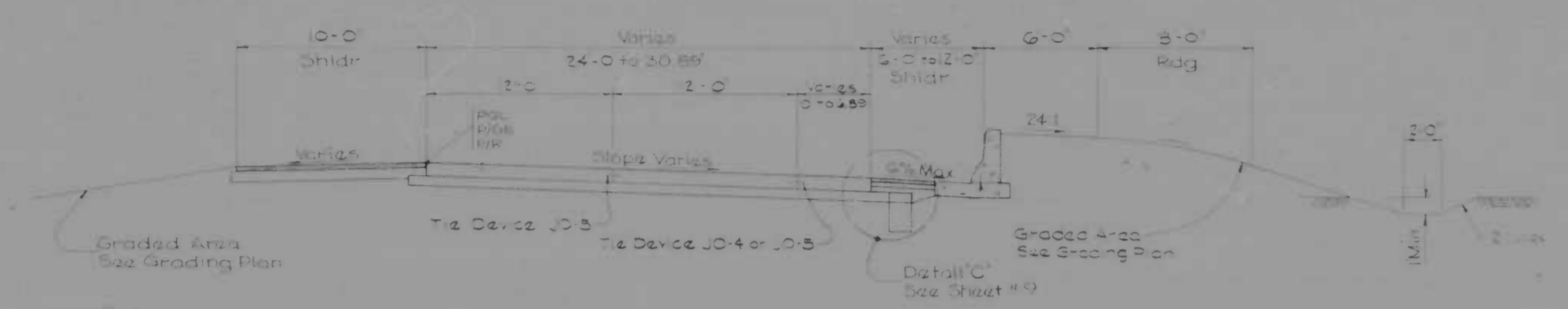

RAMP 'D'
Sta 11+85.75 to Sta 14+00
Scale: 1"=5'-0"

Note: All 500, 80000 - 2 Topsoil, Seed and Mulch

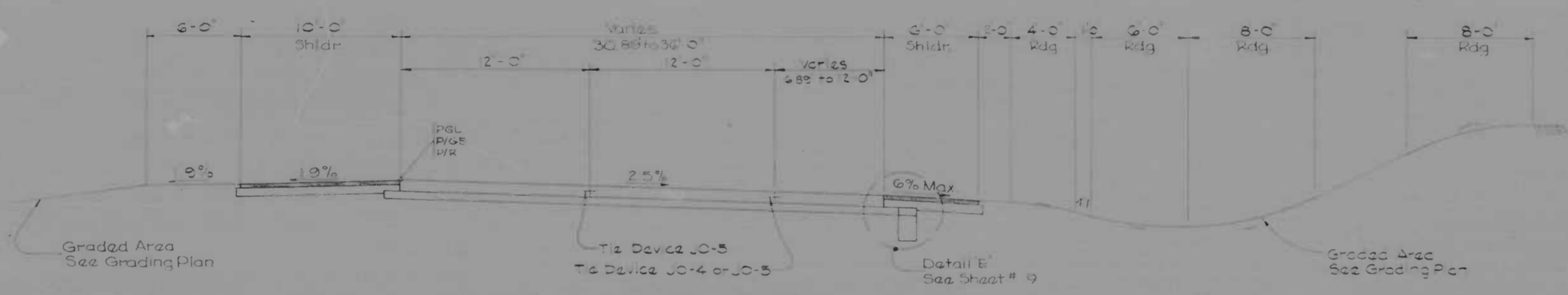

RAMP 'D'
Sta 14+00 to Sta 15+72.37
Scale: 1"=5'-0"

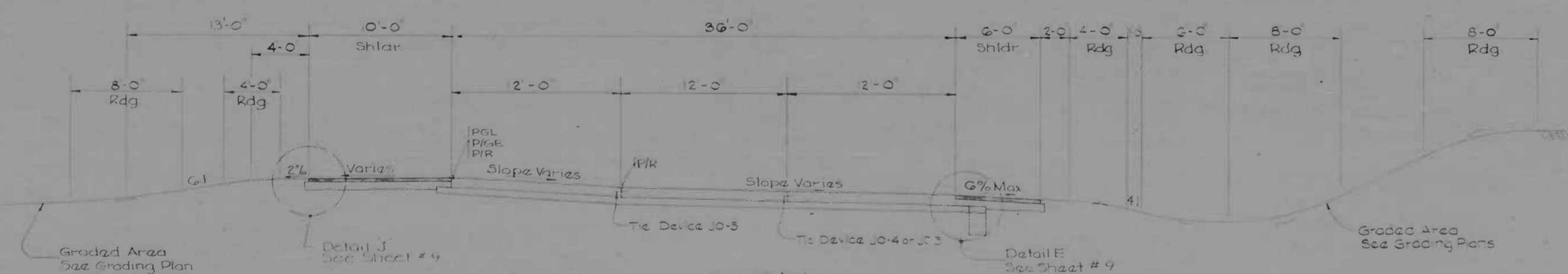

RAMP 'D'
Sta 15+72.37 to Sta 17+00
Scale: 1"=5'-0"

REVISIONS	CONSULTANT	CITY OF BALTIMORE DEPARTMENT OF PUBLIC WORKS	STATE ROADS COMMISSION OF MARYLAND INTERSTATE DIVISION FOR BALTIMORE CITY
	KNORRLE, BENDER, STONE & ASSOC., INC. MATZ, DIMAS & ASSOC., INC. CONSULTING ENGINEERS 343 N. CALVERT STREET BALTIMORE, MARYLAND 21202	INTERSTATE ROUTE 95 EASTERN AVENUE INTERCHANGE	DRAWN BY: WFF TRACED BY: JEM DES. BY: DES CHK. BY: S.W.H. F.A.P. NO. 1-95-11321-35 S.R.C. NO. DC 246-29-B10 BALTO. CITY NO. 009
		SCALE: As Shown	DATE: 4-20-70
			SHEET NO. 6 OF 113

NO. 1111111111

S T O R M D R A I N S C H E D U L E

2	MD	1-95-4(32)36	60	113
---	----	--------------	----	-----

SHEET NO. 53

4 Constr. Sta. 1+07 Eastern Avenue Rt.
 8'-18" R.C. Pipe Class IV
 1-Std. 'S' Comb. Inlet Dbl. Grate
 1-36"x18" Pipe Conn. Brick Y

4 Constr. Sta. 1+72 Eastern Avenue Rt.
 8'-18" R.C. Pipe Class IV
 1-Std. 'S' Comb. Inlet Dbl. Grate
 1-36"x18" Pipe Conn. Brick Y

4 Constr. Sta. 4+70 Eastern Avenue Lt.
 24'-13" R.C. Pipe Class IV
 1-Std. 'S' Comb. Inlet Dbl. Grate
 1-30"x18" Pipe Conn. Brick Y

4 Constr. Sta. 5+84 Eastern Avenue Rt.
 24'-18" R.C. Pipe Class IV
 1-Std. 'S' Comb. Inlet Dbl. Grate
 1-Std. Storm Water Manhole 24" Cover

4 Constr. Sta. 5+07 Eastern Avenue Rt.
 8'-18" R.C. Pipe Class IV
 1-Std. 'S' Comb. Inlet Dbl. Grate
 1-36"x18" Pipe Conn. Brick Y

4 Constr. Sta. 6+15 Eastern Avenue Rt.
 8'-18" R.C. Pipe Class IV
 1-Std. 'S' Comb. Inlet Dbl. Grate
 1-42"x18" Pipe Conn. Brick Y

4 Constr. Sta. 6+72 Eastern Avenue Lt.
 12'-18" R.C. Pipe Class IV
 1-Std. 'S' Comb. Inlet Dbl. Grate

4 Constr. Sta. 6+80 Eastern Avenue Lt.
 1-Std. 'K' Inlet Single Grate

4 Constr. Sta. 5+30 Ramp 'E' Rt.
 36'-18" B.C.C.M. Pipe Type 'C' #14 Gauge
 1-Std. 'S' Comb. Inlet Dbl. Grate
 1-End Sect. for 18" C.M. Pipe

4 Constr. Sta. 15+00 Ramp 'B' Lt.
 20'-18" R.C. Pipe Class IV
 1-End Sect. for 18" C.M. Pipe
 1-Std. 'S' Comb. Inlet Dbl. Grate

4 Constr. Sta. 15+87 Ramp 'B' Lt.
 8'-18" R.C. Pipe Class IV
 1-Std. 'S' Comb. Inlet Dbl. Grate

4 Constr. Sta. 15+87 Ramp 'B' Rt.
 48'-18" B.C.C.M. Pipe Type 'C' #12 Gauge
 1-Std. 'K' Inlet Dbl. Grate

4 Constr. Sta. 16+50 Ramp 'B' Lt.
 64'-18" B.C.C.M. Pipe Type 'C' #12 Gauge
 1-Std. 'S' Comb. Inlet Dbl. Grate

4 Constr. Sta. 7+00 to Sta. 9+00 Ramp 'C' Lt.
 188'-18" B.C.C.M. Pipe Type 'C' #14 Gauge
 1-Std. Storm Water Manhole 24" Cover
 1-36"x18" Pipe Conn. Brick Y

4 Constr. Sta. 7+30 Ramp 'C' Lt.
 12'-18" B.C.C.M. Pipe Type 'C' #14 Gauge
 1-Std. 'K' Inlet Dbl. Grate

4 Constr. Sta. 7+40 Ramp 'C' Rt.
 36'-18" B.C.C.M. Pipe Type 'C' #12 Gauge
 1-Std. 'S' Comb. Inlet Dbl. Grate

4 Constr. Sta. 3+25 Ramp 'E' Rt.
 12'-18" B.C.C.M. Pipe Type 'C' #14 Gauge
 1-Std. 'K' Inlet Single Grate

4 Constr. Sta. 3+39 to Sta. 7+15 Ramp 'E' Rt.
 380'-18" R.C. Pipe Class IV
 2-Std. Storm Water Manholes 24" Covers

4 Constr. Sta. 4+95 Ramp 'E' Rt.
 20'-18" B.C.C.M. Pipe Type 'C' #14 Gauge
 1-18"x18" Pipe Conn. Brick Y
 1-Std. 'S' Comb. Inlet Dbl. Grate

4 Constr. Sta. 7+10 Ramp 'E' Rt.
 24'-18" B.C.C.M. Pipe Type 'C' #12 Gauge
 1-Std. 'S' Comb. Inlet Dbl. Grate

4 Constr. Sta. 7+15 Ramp 'E' Rt.
 48'-18" R.C. Pipe Class IV
 1-Std. Storm Water Manhole 24" Cover

4 Constr. Sta. 7+25 Ramp 'E' Rt.
 12'-18" B.C.C.M. Pipe Type 'C' #14 Gauge
 1-Std. 'K' Inlet Single Grate

4 Constr. Sta. 7+75 Ramp 'E' Rt.
 68'-18" B.C.C.M. Pipe Type 'C' #12 Gauge
 1-Mod. 'S' Comb. Inlet Dbl. Grate

4 Constr. Sta. 8+40 Ramp 'E' Rt.
 64'-18" B.C.C.M. Pipe Type 'C' #12 Gauge
 1-Mod. 'S' Comb. Inlet Dbl. Grate

4 Constr. Sta. 9+15 Ramp 'E' Rt.
 80'-18" B.C.C.M. Pipe Type 'C' #12 Gauge
 1-Mod. 'S' Comb. Inlet Dbl. Grate

4 Constr. Sta. 358+80 Rt.
 28'-18" B.C.C.M. Pipe Type 'C' #14 Gauge
 1-End Sect. for 18" C.M. Pipe
 1-Mod. 'S' Comb. Inlet Dbl. Grate

4 Constr. Sta. 361+30 Lt. & Rt.
 192'-24" B.C.C.M. Pipe Type 'C' #12 Gauge
 48'-24" B.C.C.M. Pipe Type 'C' #14 Gauge
 1-End Sect. for 24" C.M. Pipe
 4-Mod. 'S' Comb. Inlets Dbl. Grates

4 Constr. Sta. 363+80 Lt. & Rt.
 166'-24" B.C.C.M. Pipe Type 'C' #12 Gauge
 60'-24" B.C.C.M. Pipe Type 'C' #14 Gauge
 1-End Sect. for 24" C.M. Pipe
 4-Mod. 'S' Comb. Inlets Dbl. Grates

4 Constr. Sta. 365+30 Lt.
 60'-54" R.C. Pipe Class IV
 1-60"x54" Special Structure Bellmouth
 1-Special B-Headwall

4 Constr. Sta. 366+30 Lt. & Rt.
 152'-24" B.C.C.M. Pipe Type 'C' #12 Gauge
 80'-24" B.C.C.M. Pipe Type 'C' #14 Gauge
 1-End Sect. for 24" C.M. Pipe
 4-Mod. 'S' Comb. Inlets Dbl. Grates

4 Constr. Sta. 4+80 Ramp 'B' Rt.
 36'-18" B.C.C.M. Pipe Type 'C' #14 Gauge
 1-Mod. 'S' Comb. Inlet Dbl. Grate
 1-End Sect. for 18" C.M. Pipe

SHEET NO. 54

SHEET NO. 54

4 Constr. Sta. 347+93 to Sta. 351+95 Rt.
 404'-24" R.C. Pipe Class IV
 2-Std. Storm Water Manholes 24" Covers

4 Constr. Sta. 348+05 Rt.
 12'-18" B.C.C.M. Pipe Type 'C' #14 Gauge
 1-Std. 'K' Inlet Single Grate

4 Constr. Sta. 348+85 Lt. & Rt.
 116'-18" B.C.C.M. Pipe Type 'C' #12 Gauge
 2-Mod. 'S' Comb. Inlets Dbl. Grates

4 Constr. Sta. 348+89 to Sta. 352+90 Lt.
 400'-21" R.C. Pipe Class IV
 1-Std. Storm Water Manhole 24" Cover

4 Constr. Sta. 349+12 Rt.
 8'-18" B.C.C.M. Pipe Type 'C' #14 Gauge
 1-Mod. 'S' Comb. Inlet Dbl. Grate
 1-24"x18" Pipe Conn. Brick Y

4 Constr. Sta. 351+30 Lt. & Rt.
 120'-18" B.C.C.M. Pipe Type 'C' #12 Gauge
 2-Mod. 'S' Comb. Inlets Dbl. Grates
 1-21"x18" Pipe Conn. Brick Y

4 Constr. Sta. 352+25 Rt.
 32'-18" B.C.C.M. Pipe Type 'C' #14 Gauge
 1-Mod. 'S' Comb. Inlet Dbl. Grate

4 Constr. Sta. 352+90 to Sta. 356+33 Lt.
 366'-18" R.C. Pipe Class IV
 2-Std. Storm Water Manholes 24" Covers

4 Constr. Sta. 353+80 Lt. & Rt.
 132'-18" B.C.C.M. Pipe Type 'C' #12 Gauge
 2-Mod. 'S' Comb. Inlets Dbl. Grates
 1-18"x18" Pipe Conn. Brick Y

4 Constr. Sta. 35+50 Ramp 'B' Lt.
 20'-18" B.C.C.M. Pipe Type 'C' #14 Gauge
 1-End Sect. for 18" C.M. Pipe
 1-Std. 'S' Comb. Inlet Dbl. Grate

4 Constr. Sta. 347+93 to Sta. 351+95 Rt.
 404'-24" R.C. Pipe Class IV
 2-Std. Storm Water Manholes 24" Covers

4 Constr. Sta. 348+05 Rt.
 12'-18" B.C.C.M. Pipe Type 'C' #14 Gauge
 1-Std. 'K' Inlet Single Grate

4 Constr. Sta. 348+85 Lt. & Rt.
 116'-18" B.C.C.M. Pipe Type 'C' #12 Gauge
 2-Mod. 'S' Comb. Inlets Dbl. Grates

4 Constr. Sta. 348+89 to Sta. 352+90 Lt.
 400'-21" R.C. Pipe Class IV
 1-Std. Storm Water Manhole 24" Cover

4 Constr. Sta. 349+12 Rt.
 8'-18" B.C.C.M. Pipe Type 'C' #14 Gauge
 1-Mod. 'S' Comb. Inlet Dbl. Grate
 1-24"x18" Pipe Conn. Brick Y

4 Constr. Sta. 351+30 Lt. & Rt.
 120'-18" B.C.C.M. Pipe Type 'C' #12 Gauge
 2-Mod. 'S' Comb. Inlets Dbl. Grates
 1-21"x18" Pipe Conn. Brick Y

4 Constr. Sta. 352+25 Rt.
 32'-18" B.C.C.M. Pipe Type 'C' #14 Gauge
 1-Mod. 'S' Comb. Inlet Dbl. Grate

4 Constr. Sta. 352+90 to Sta. 356+33 Lt.
 366'-18" R.C. Pipe Class IV
 2-Std. Storm Water Manholes 24" Covers

4 Constr. Sta. 353+80 Lt. & Rt.
 132'-18" B.C.C.M. Pipe Type 'C' #12 Gauge
 2-Mod. 'S' Comb. Inlets Dbl. Grates
 1-18"x18" Pipe Conn. Brick Y

4 Constr. Sta. 35+50 Ramp 'B' Lt.
 20'-18" B.C.C.M. Pipe Type 'C' #14 Gauge
 1-End Sect. for 18" C.M. Pipe
 1-Std. 'S' Comb. Inlet Dbl. Grate

SHEET NO. 55

4 Constr. Sta. 356+30 Rt. & Lt.
 156'-18" B.C.C.M. Pipe Type 'C' #14 Gauge
 2-Mod. 'S' Comb. Inlets Dbl. Grates

4 Constr. Sta. 357+00 Rt.
 116'-18" R.C. Pipe Class IV
 1-Mod. 'S' Comb. Inlet Dbl. Grate
 1-54"x18" Pipe Conn. Collar Tap

4 Constr. Sta. 357+50 Rt.
 16'-18" R.C. Pipe Class IV
 1-Std. 'K' Inlet Dbl. Grate
 1-54"x21" Pipe Conn. Collar Tap

4 Constr. Sta. 357+75 Lt. & Rt.
 386'-54" R.C. Pipe Class IV
 1-54" Pipe Conn. Brick Curve
 1-Std. B-54 Headwall

4 Constr. Sta. 358+00 Lt. & Rt.
 120'-18" R.C. Pipe Class IV
 1-54" Pipe Conn. Collar Tap
 2-Mod. 'S' Comb. Inlets Dbl. Grates

SHEET NO. 55

4 Constr. Sta. 368+10 Lt. & Rt.
 384'-42" B.C.C.M. Pipe Type 'C' #8 Gauge
 1-End Support Wall for 42" C.M. Pipe
 1-Std. Type 'C' Endwall for 42" C.M. Pipe

4 Constr. Sta. 368+60 Lt. & Rt.
 152'-24" B.C.C.M. Pipe Type 'C' #12 Gauge
 80'-24" B.C.C.M. Pipe Type 'C' #14 Gauge
 1-End Sect. for 24" C.M. Pipe
 4-Mod. 'S' Comb. Inlets Dbl. Grates

SHEET NO. 57

4 Constr. Sta. 6+85 Eastern Avenue Detour Road
 24'-30" V.C. Extra Strength

4 Constr. Sta. 8+00 Eastern Avenue Detour Road
 64'-18" B.C.C.M. Pipe Type 'A' #12 Gauge
 2-End Sect. for 18" C.M. Pipe

4 Constr. Sta. 11+25 Eastern Avenue Detour Road
 92'-22"x13" B.C.C.M. Pipe Arch Type 'A' #12 Gauge
 2-End Sect. for 22"x13" C.M. Pipe

REVISIONS	CONSULTANT	CITY OF BALTIMORE DEPARTMENT OF PUBLIC WORKS		STATE ROADS COMMISSION OF MARYLAND INTERSTATE DIVISION FOR BALTIMORE CITY	
	KNORR, BENDER, STONE & ASSOC., INC. MAY MATZ, CHILDS & ASSOC., INC. CONSULTING ENGINEERS 541 N. CALVERT STREET BALTIMORE, MARYLAND 21202	INTERSTATE ROUTE 95 EASTERN AVENUE INTERCHANGE		DRAWN BY: WFF TRACED BY: R.K.	DES. BY: CEP CHK. BY: J.G.C.
		SCALE	DATE: 6-3-70	F.A.P. NO. 1-95-4(32)36 S.R.C. NO. BC 246-29-85	SHEET NO. 60 OF 113

PROJECT NO.	STATE	SECTION	SHEET NO.	TOTAL SHEETS
2	MD.	1-95-4(32)36	36	113

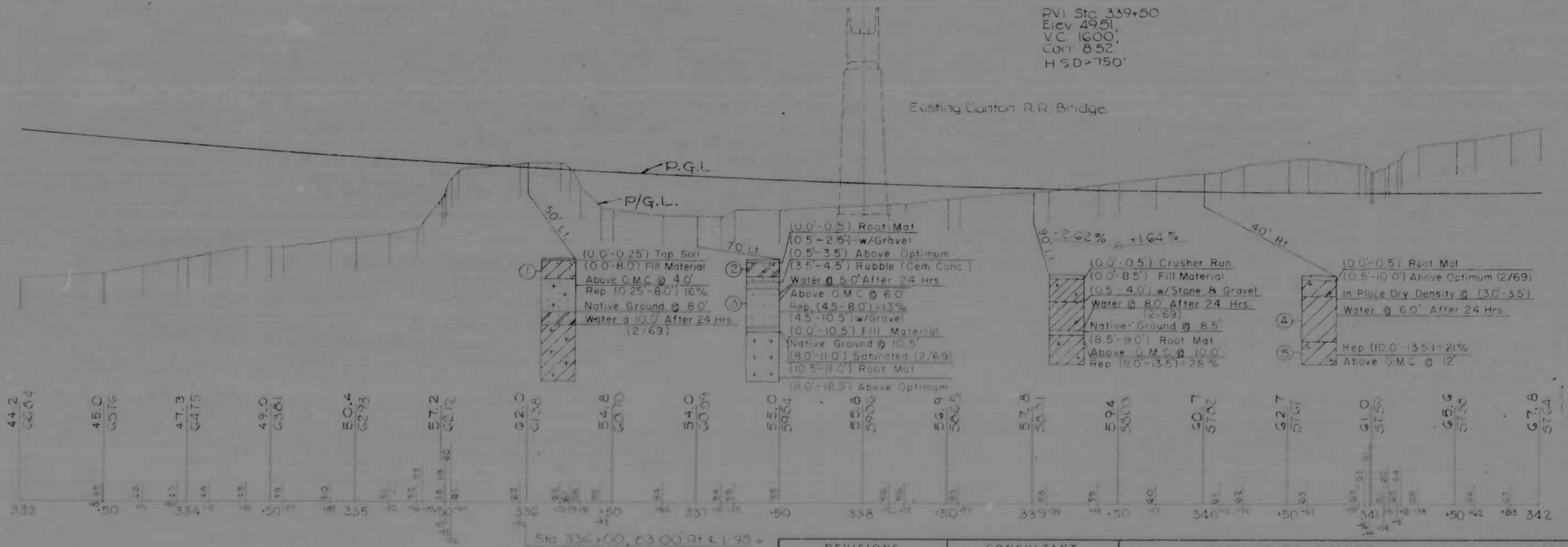
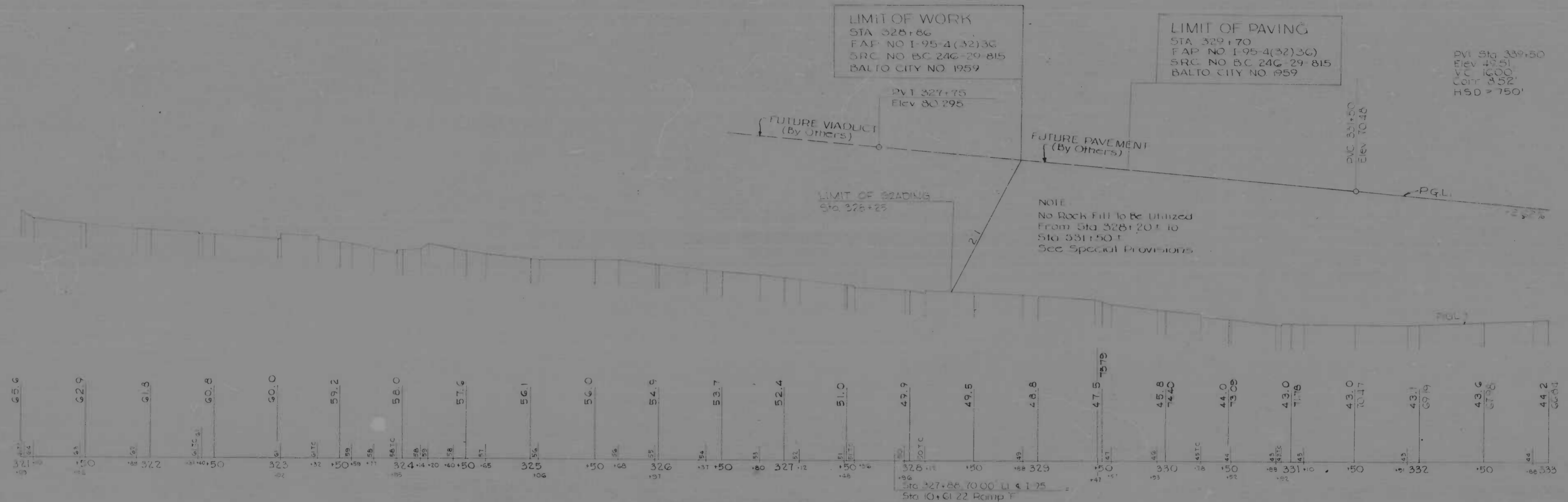

REVISIONS	CONSULTANT	CITY OF BALTIMORE	STATE ROADS COMMISSION OF MARYLAND
	ENGINEER, DESIGNER, SURVEYOR & ASSOC., INC.	DEPARTMENT OF PUBLIC WORKS	INTERSTATE DIVISION FOR BALTIMORE CITY
	ENGINEERING ENGINEERS	INTERSTATE ROUTE 95	DRAWN BY: J.E.P.
	341 N. CALVERT STREET	EASTERN AVENUE INTERCHANGE	DESIGNED BY: S.W.H.
	BALTIMORE, MARYLAND 21202		CHECKED BY: J.L.S.
		SCALE: HORIZ. 1"=40' VERT. 1"=10'	FAP NO. 1-95-4(32)36
		DATE: 8-3-70	SRC NO. BC 246-29-815
			BALTO. CITY NO. 1959

FED. ROAD DIST. NO.	STATE	FED. AID PROJ. NO.	SHEET NO.	TOTAL SHEETS
2	MD.	1-95-432136	82	113

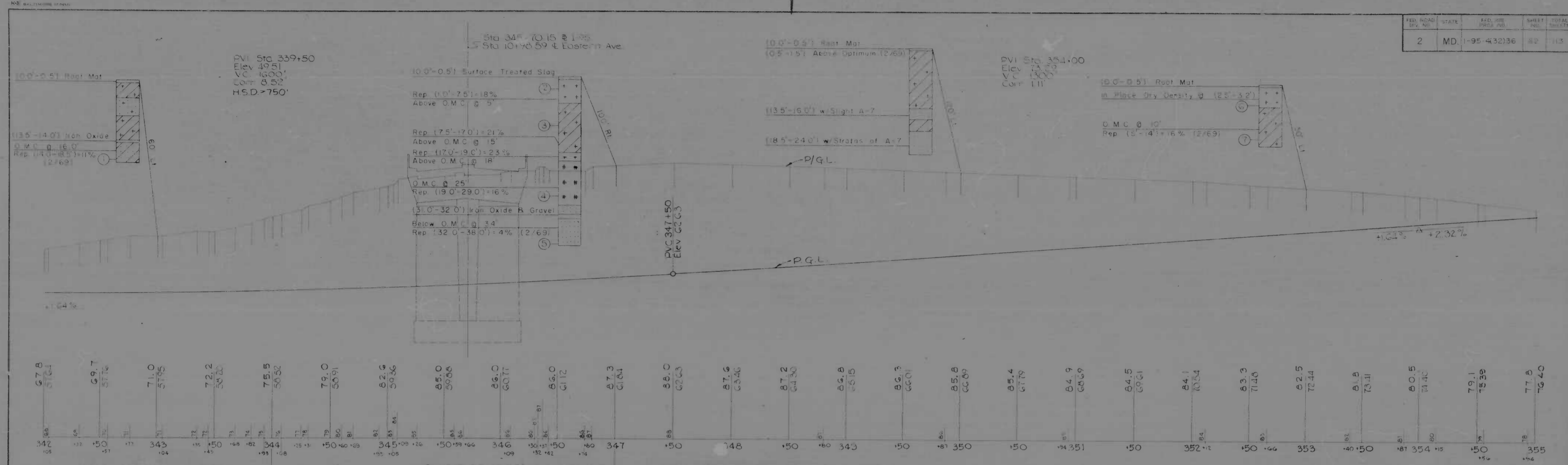

INTERSTATE ROUTE 95
Datum 25

SOILS TEST DATA				
NO.	LL	PI	Max Den	Opt Moist
1	20	NP		
2	39	16		
3	35	13	III PCF @ 15%	
4	38	17	III PCF @ 16%	
5	NP	NP		
6	45	21	103 PCF @ 20%	
7	33	13	113 PCF @ 16%	

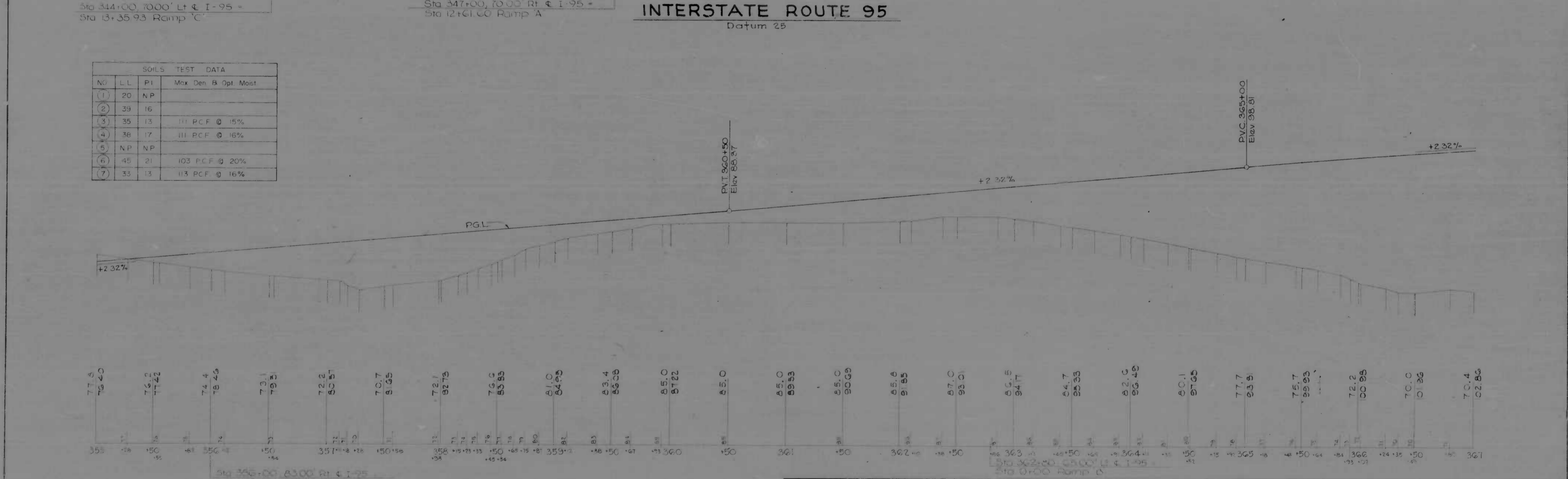

INTERSTATE ROUTE 95
Datum 35

REVISIONS	CONSULTANT	CITY OF BALTIMORE	STATE ROADS COMMISSION OF MARYLAND
	KROENEL, BENDER, STONE & ASSOC., INC.	DEPARTMENT OF PUBLIC WORKS	INTERSTATE DIVISION FOR BALTIMORE CITY
	MATZ CHILDS & ASSOC., INC.	INTERSTATE ROUTE 95	DRAWN BY: C.E.P.
	CONSULTING ENGINEERS	EASTERN AVENUE INTERCHANGE	TRACED BY: W.E.F.
	BALTIMORE, MARYLAND 21202		CHK BY: D.E.S.
		SCALE: HORIZ. 1"=40' VERT. 1"=10'	DATE: 6-3-70
			F.A.P. NO. 1-95-432136
			S.R.C. NO. BC 245-29-815
			BALTO. CITY NO. 1959
			SHEET NO. 82 OF 113

FED. ROAD DIST. NO.	STATE	FED. AID PROJ. NO.	SHEET NO.	TOTAL SHEETS
2	MD	1-95-4132136	63	113

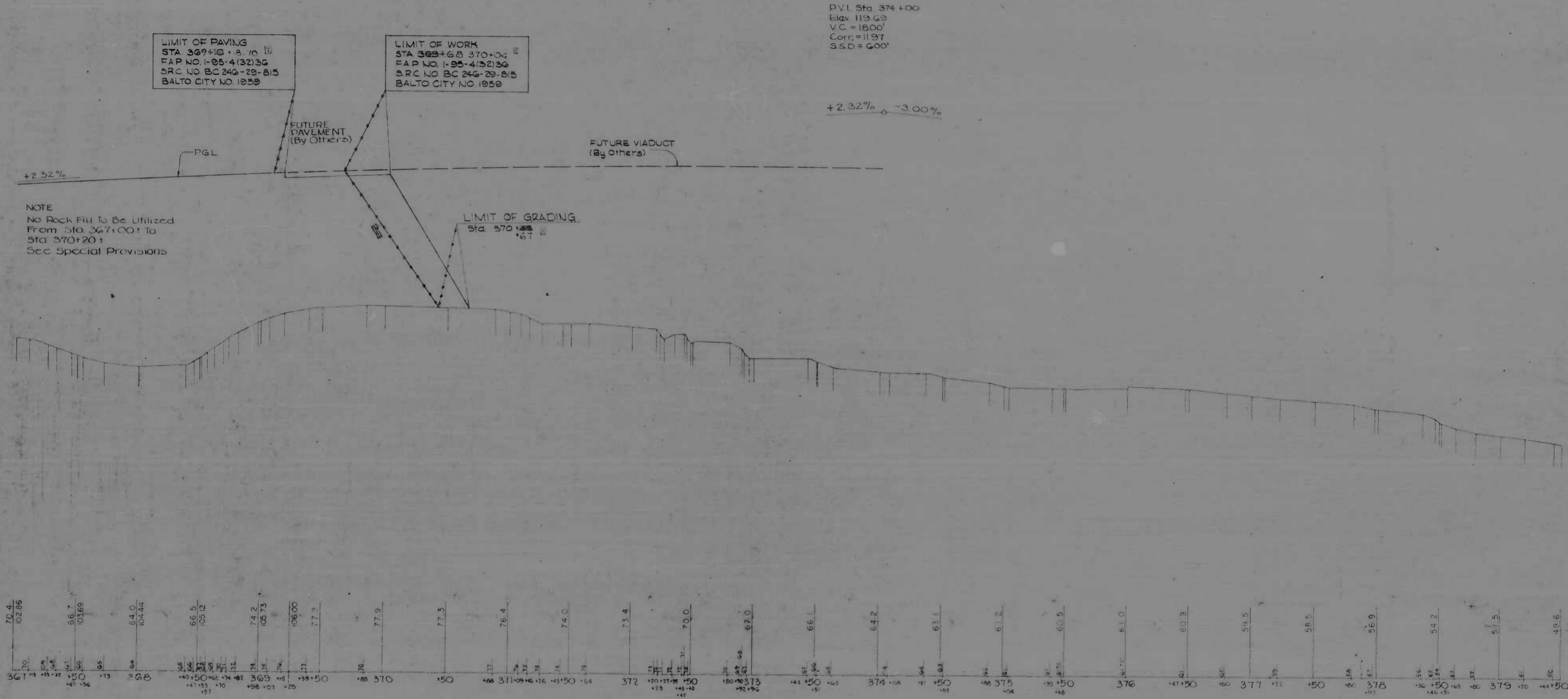

LIMIT OF PAVING
STA 369+13 + 3.70 (1)
FAP NO. 1-95-4132136
S.R.C. NO. BC 246-29-815
BALTO CITY NO. 1959

LIMIT OF WORK
STA 369+68 370+04 (8)
FAP NO. 1-95-4132136
S.R.C. NO. BC 246-29-815
BALTO CITY NO. 1959

P.V.I. Sta. 374+00
Elev. 115.69
V.C. = 1800'
COTT. = 11.97
S.S.O. = 6.00'

NOTE
No Rock Fill To Be Utilized
From Sta. 367+00 to
Sta. 370+20.1
See Special Provisions

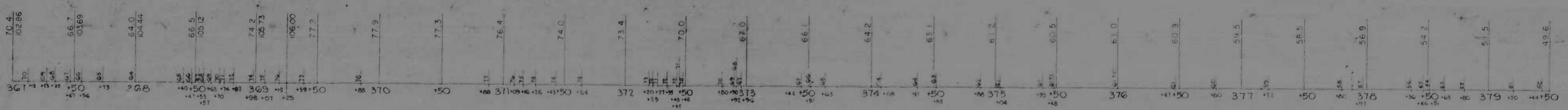

INTERSTATE ROUTE 95
Datum 0

REVISIONS 1) See Limit of Paving, Work Limits, 4-21-77	CONSULTANT KIMBLE, BENJER, STONE & ASSOC., INC. AND MATZ, CONRAD & ASSOC., INC. CONSULTING ENGINEERS 241 N. CALVERT STREET BALTIMORE, MARYLAND 21202	CITY OF BALTIMORE DEPARTMENT OF PUBLIC WORKS & STATE ROADS COMMISSION OF MARYLAND INTERSTATE DIVISION FOR BALTIMORE CITY	
		INTERSTATE ROUTE 95 EASTERN AVENUE INTERCHANGE	DRAWN BY K.V.W. TRACED BY W.T.F. F.A.P. NO. 1-95-4132136 S.R.C. NO. BC 246-29-815 BALTO CITY NO. 1959
SCALE: Hor. 1"=40' Vert. 1"=10' DATE: 6-3-70		DES. BY D.E.S. CHK. BY S.W.H.	SHEET NO. 63 of 113

FED. ROAD DIST. NO.	STATE	FED. AID PROJ. NO.	SHEET NO.	TOTAL SHEETS
2	MD.	I-95-4(32)36	64	113

LIMIT OF WORK
 STA 0+52 EASTERN AVE
 F.A.P. NO I-95-4(32)36
 S.R.C. NO. BC 24-29-815
 BALTO. CITY NO 1959

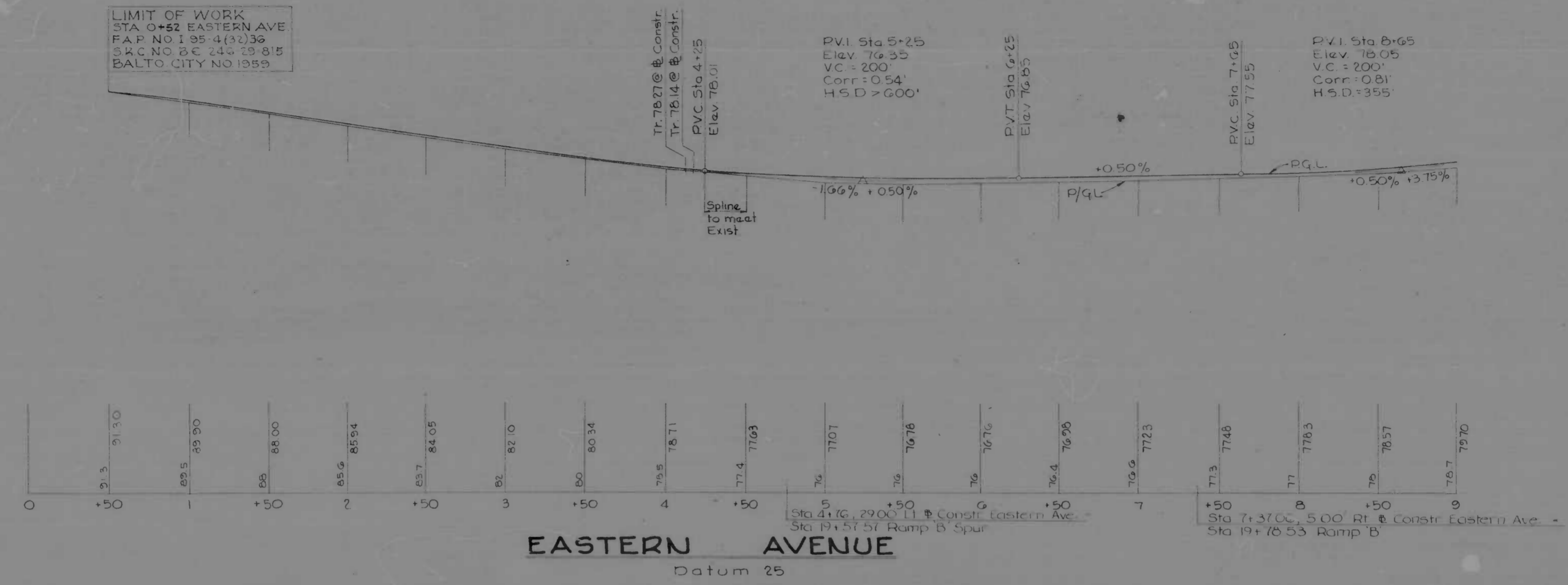

EASTERN AVENUE
 Datum 25

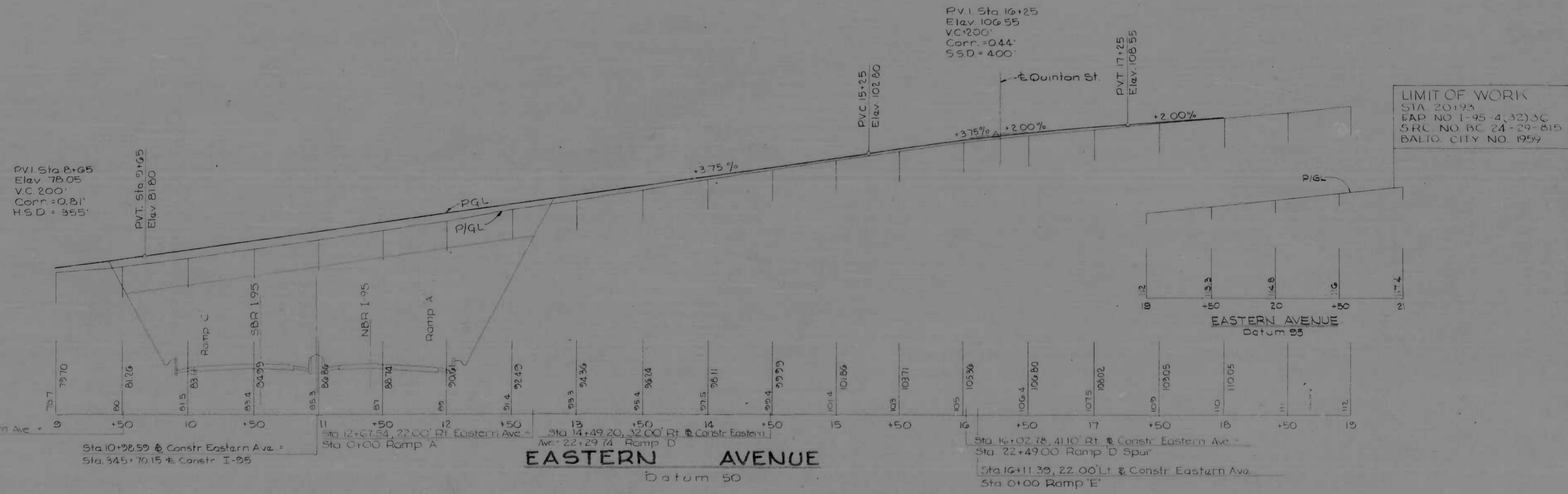

EASTERN AVENUE
 Datum 50

Sta 9+51.59 22.00' Lt Eastern Ave - Sta 0+00 Ramp C
 Sta 10+28.59 @ Constr Eastern Ave - Sta 345+70.15 @ Constr I-95
 Sta 12+67.54, 22.00' Rt Eastern Ave - Sta 0+00 Ramp A
 Sta 14+49.20, 32.00' Rt Eastern Ave - Sta 22+29.74 Ramp D
 Sta 16+02.78, 41.10' Rt Eastern Ave - Sta 22+49.00 Ramp D Spur
 Sta 16+11.39, 22.00' Lt Eastern Ave - Sta 0+00 Ramp E

REVISIONS	CONSULTANT	CITY OF BALTIMORE DEPARTMENT OF PUBLIC WORKS	STATE ROADS COMMISSION OF MARYLAND INTERSTATE DIVISION FOR BALTIMORE CITY
	KNORRLE, BENDER, STONE & ASSOC., INC. AND MATZ, CHILDS & ASSOC., INC. CONSULTING ENGINEERS 341 N. CALVERT STREET BALTIMORE, MARYLAND 21202		
	DRAWN BY: R.F.D.	DES. BY: D.E.S.	SHEET NO.
	TRACED BY: R.F.D.	CHK. BY: V.F.H.	61 of 113
	F.A.P. NO. I-95-4(32)36		
	S.R.C. NO. BC 24-29-815		
	BALTO. CITY NO 1959		
	SCALE: Hor. 1"=40' Vert. 1"=10'	DATE: 6-3-70	

FILE NO.	YEAR	REV. NO.	DATE	BY	CHK.
2	MD	1-95-4132136	65	113	



Sta 0+00 Ramp A
Sta 12+00 Ramp A
Datum 25

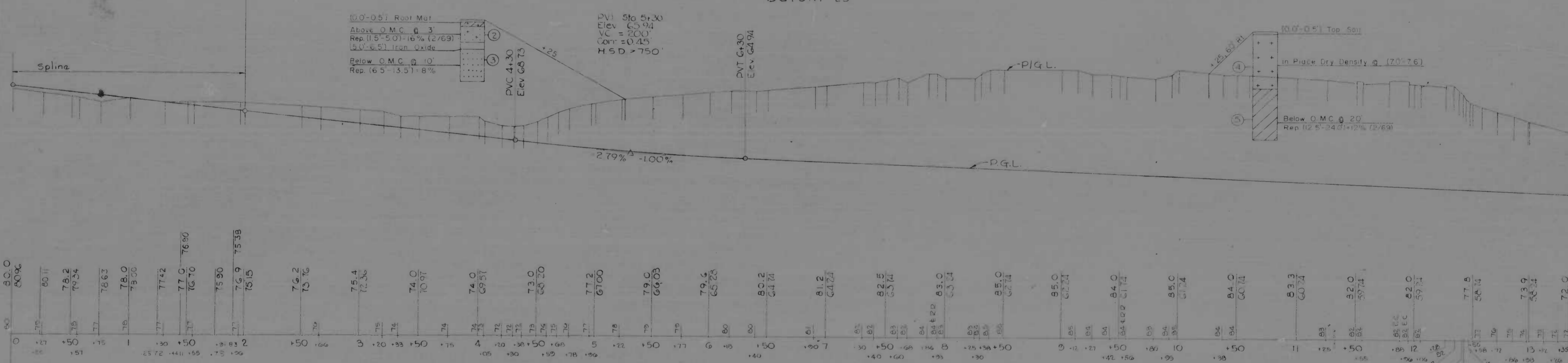

Sta 0+00 Ramp C
Sta 13+35 Ramp C
Datum 25

SOILS TEST DATA				
NO.	L	B	Max. Dep. B	Dist. Multi
1	38	15		
2	27	8		
3	38	16	109	P.C.F. @ 18%
4	22	8		

REVISIONS	CONSULTANT	CITY OF BALTIMORE DEPARTMENT OF PUBLIC WORKS	STATE ROADS COMMISSION OF MARYLAND INTERSTATE DIVISION FOR BALTIMORE CITY
	KIMBLE, BENDER, STONE & ASSOC., INC. 145 WATZ, CHURCH & ASSOC., INC. CONSULTING ENGINEERS 341 N. CALVERT STREET BALTIMORE, MARYL. MD 21202	INTERSTATE ROUTE 95 EASTERN AVENUE INTERCHANGE	DRAWN BY R.F.D. TRACED BY R.F.D. DES. BY H.E.L. CHK. BY E.E.S.
		SCALE: HOR. 1"=40' VERT. 1"=10'	DATE: 8-3-70
			SHEET NO. 85 OF 112

FILE NO.	DATE	DESIGN NO.	SHEET NO.	TOTAL SHEETS
2	MD	1-95-4(32)36	66	113

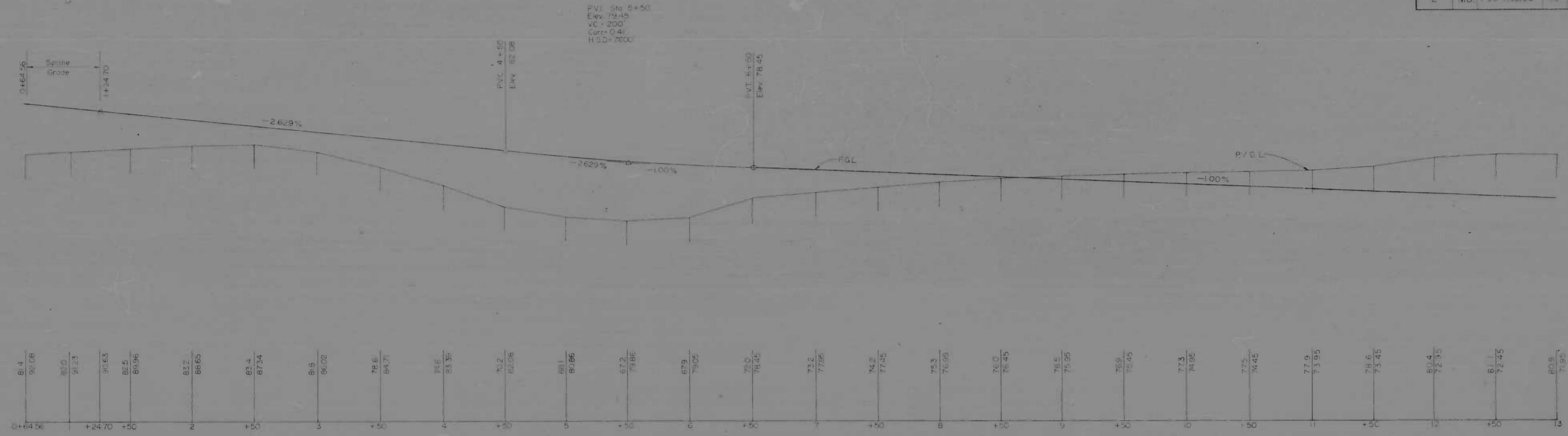

RAMP 'B'
Datum 25

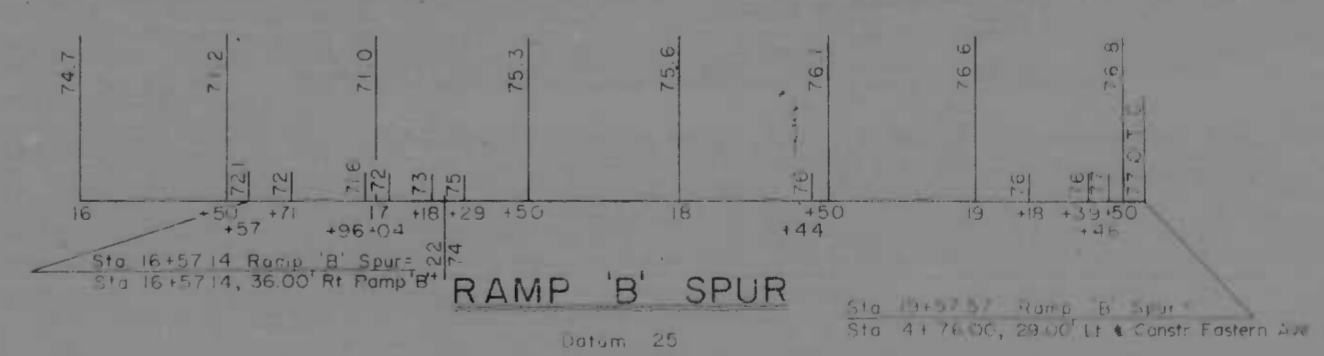
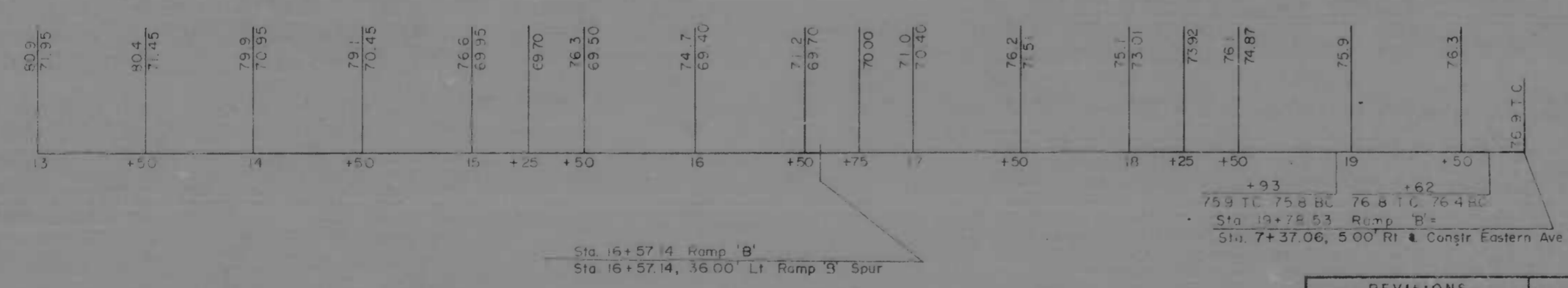
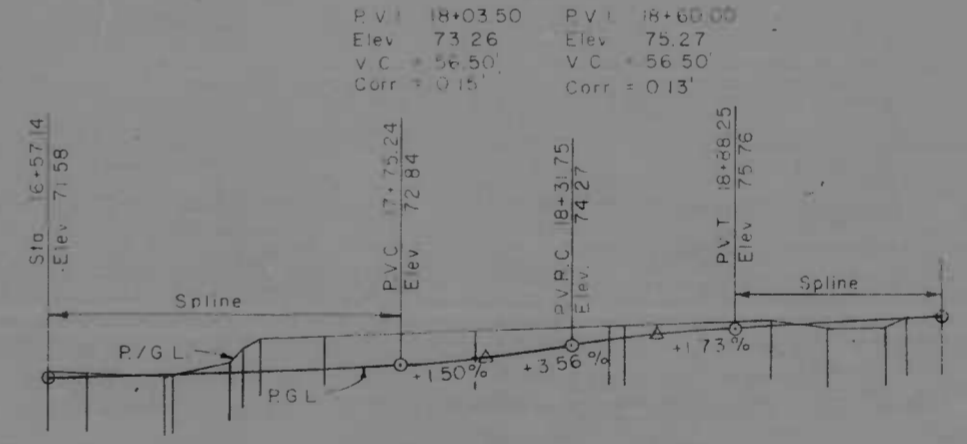
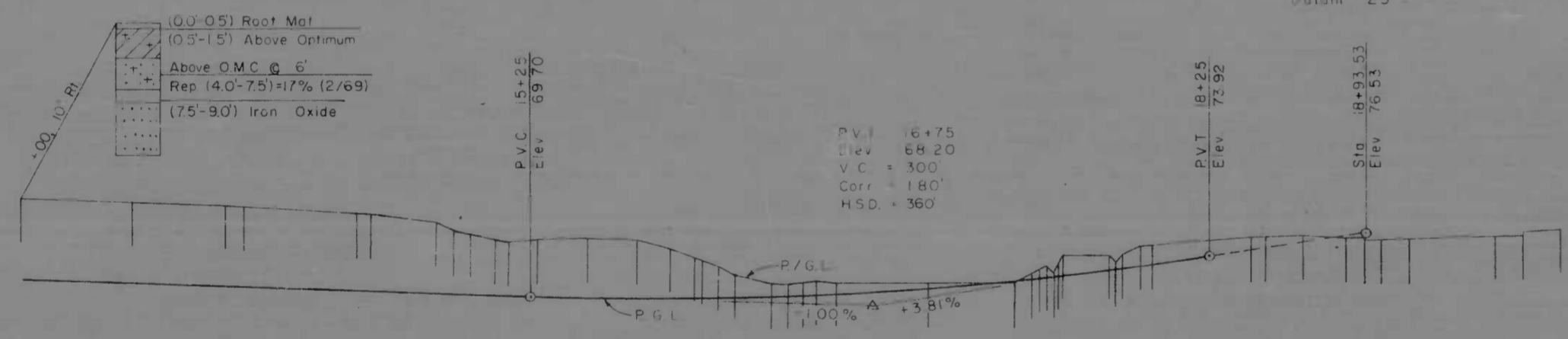

RAMP 'B'
Datum 25

REVISIONS	CONSULTANT	CITY OF BALTIMORE DEPARTMENT OF PUBLIC WORKS	STATE ROADS COMMISSION OF MARYLAND INTERSTATE DIVISION FOR BALTIMORE CITY
	KINDRICK, BENDER, STONE & ASSOC., INC. AND MATZ, CHURCH & ASSOC., INC. CONSULTING ENGINEERS 341 N. CALVERT STREET BALTIMORE, MARYLAND 21202	INTERSTATE ROUTE 95 EASTERN AVENUE INTERCHANGE	DRAWN BY: K.V.W. TRACED BY: L.R.P. F.A.P. NO. 1-95-4(32)36 S.R.C. NO. BC 246-29-B13 BALTO CITY NO. 1959
		SCALE: Hor 1"=40' Vert 1"=10'	DATE: 6-3-70
			DES. BY: H.E.L. CHK. BY: D.E.S. SHEET NO. 66 OF 113

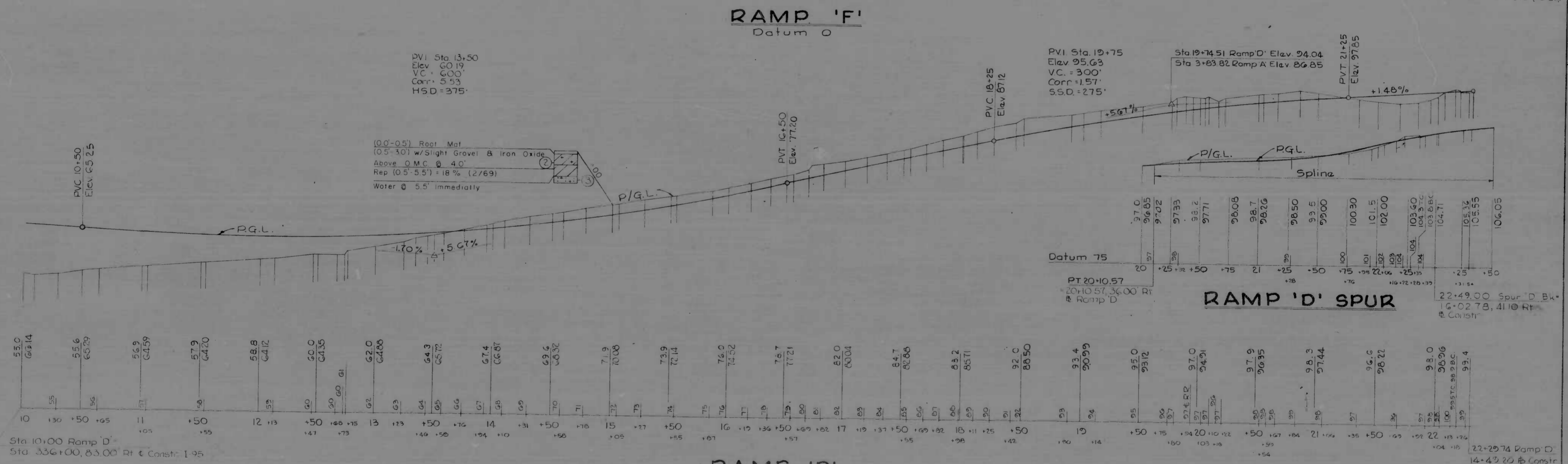
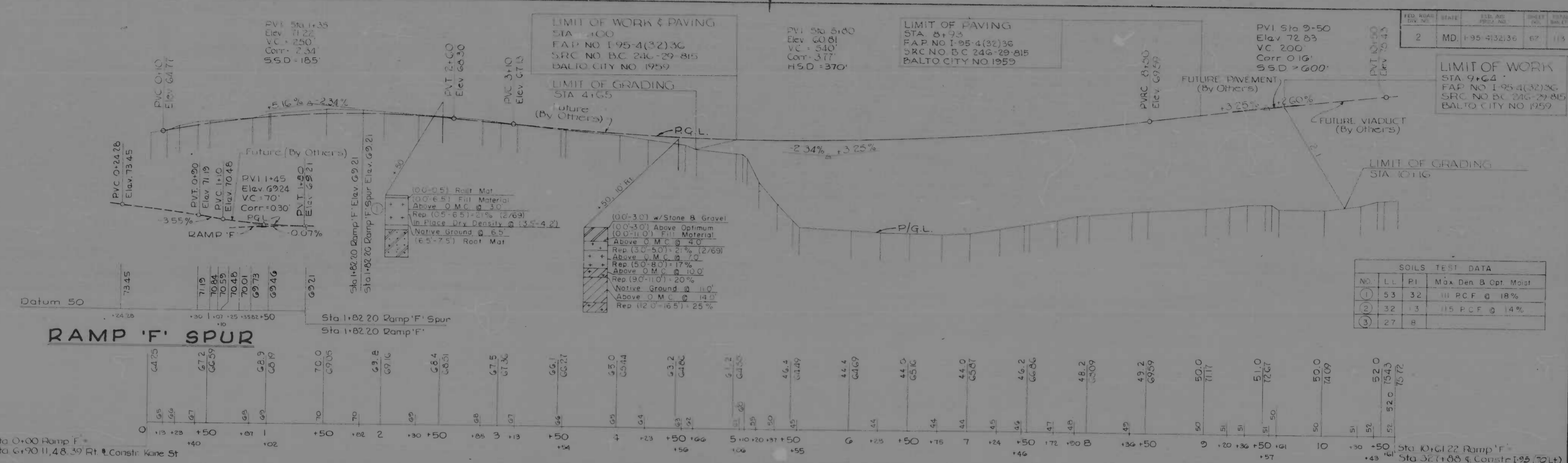

REVISIONS	CONSULTANT	CITY OF BALTIMORE DEPARTMENT OF PUBLIC WORKS	STATE ROADS COMMISSION OF MARYLAND INTERSTATE DIVISION FOR BALTIMORE CITY
	KNORRLE, BENDER, STONE & ASSOC., INC. AND MATZ, CHILDS & ASSOC., INC. CONSULTING ENGINEERS 34 N. CALVERT STREET BALTIMORE, MARYLAND 21202	INTERSTATE ROUTE 95 EASTERN AVENUE INTERCHANGE	DRAWN BY: R.F.D. TRACEY BY: R.F.D. DES. BY: H.E.L. CHK BY: D.E.S.
		SCALE: Hor. 1"=40' Vert. 1"=10'	DATE: 6-3-70
			SHEET NO. 67 OF 112

2	ML	95-4132136	58	115
---	----	------------	----	-----

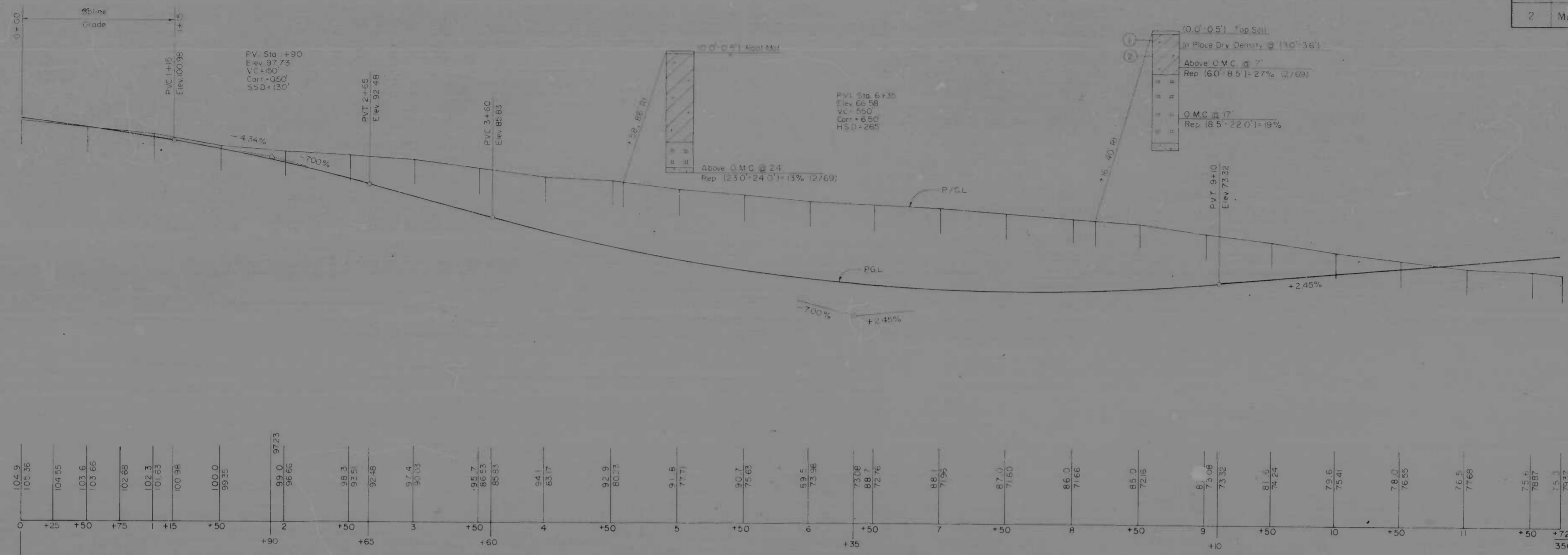

Sta 0+00 Ramp 'E'
Sta 16+11.39, 22.00' Lt. R. Constr. Eastern Ave

RAMP 'E'
Datum 25

REVISIONS CONSULTANT KNOERLE, BENDER, STONE & ASSOC., INC. MATZ, CHILDS & ASSOC., INC. CONSULTING ENGINEERS 341 N. CALVERT STREET BALTIMORE, MARYLAND 21202	CITY OF BALTIMORE DEPARTMENT OF PUBLIC WORKS & STATE ROADS COMMISSION OF MARYLAND INTERSTATE ROUTE 95 EASTERN AVENUE INTERCHANGE		INTERSTATE DIVISION FOR BALTIMORE CITY DRAWN BY: RFD DES. BY: HEL TRACED BY: RFD CHK. BY: DES F.P. NO. 95-4132136 S.R.C. NO. BC 246-29-815 BALTO. CITY NO. 1959	
	SCALE: Hor 1"=40' Vert 1"=10' DATE: E-3-70		SHEET NO. 58 of 115	

FED. ROAD DIST. NO.	STATE	PROJ. NO.	SHEET NO.	TOTAL SHEETS
2	MD	1-95-41321-36	69	113

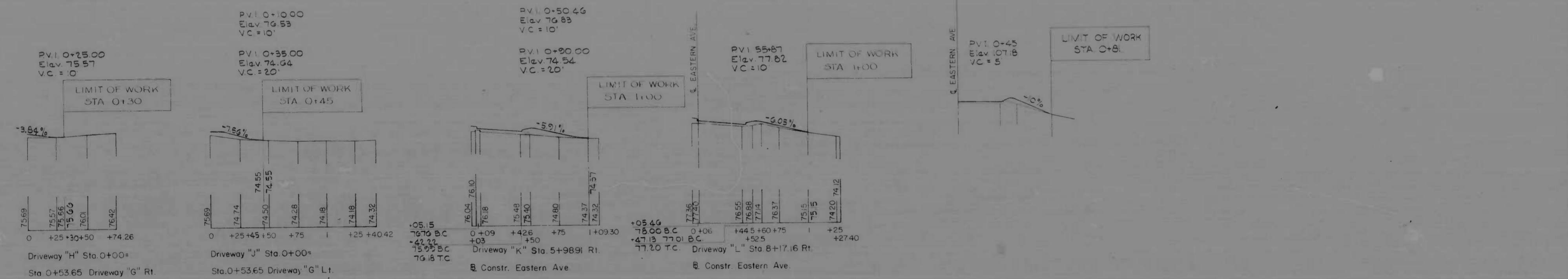
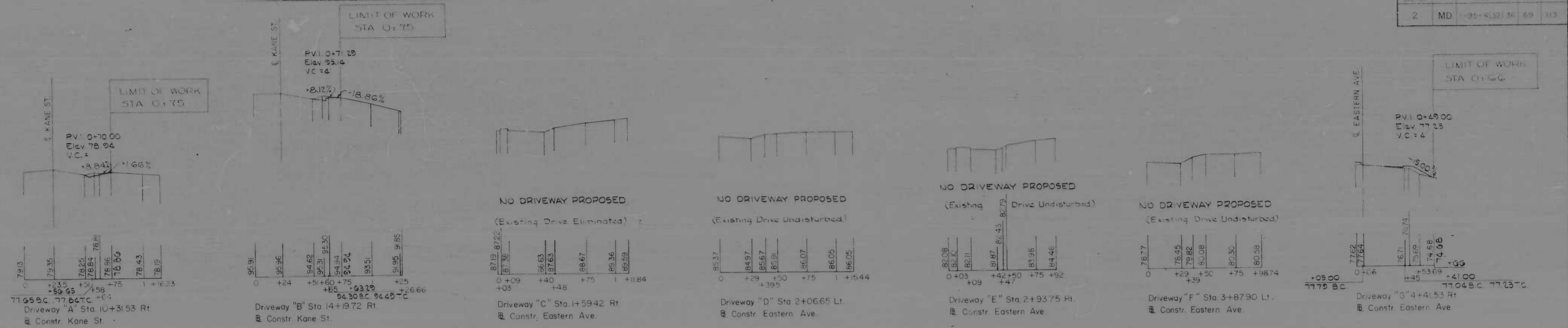

DRIVEWAY PROFILES

Datum 55
Scale: Hor. 1" = 40'
Vert. 1" = 10'

1062
1057
1060
1062
1037
1036

+37 +50 +81
Driveway M Sta. 16+83 RT.
Constr. Eastern Ave.

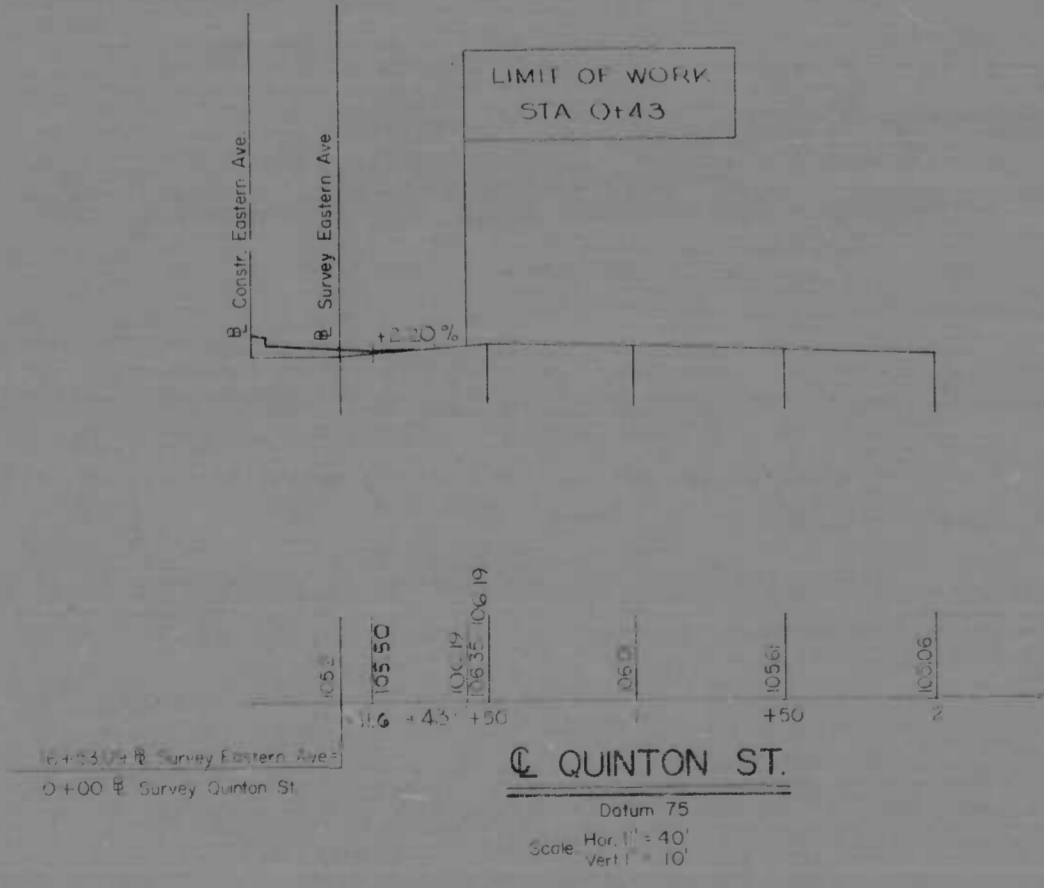

QUINTON ST.
Datum 75
Scale: Hor. 1" = 40'
Vert. 1" = 10'

REVISIONS	CONSULTANT	CITY OF BALTIMORE DEPARTMENT OF PUBLIC WORKS	STATE ROADS COMMISSION OF MARYLAND INTERSTATE DIVISION FOR BALTIMORE CITY
	KIMBLE, BENDER, STONE & ASSOC., INC. AND MATZ, CHILDS & ASSOC., INC. CONSULTING ENGINEERS 341 N. CALVERT STREET BALTIMORE, MARYLAND 21202	INTERSTATE ROUTE 95 EASTERN AVENUE INTERCHANGE	DRAWN BY: E.F.P. TRACED BY: E.F.P. F.A.P. NO. 1-95-41321-36 S.R.C. NO. 82-265-29-815 BALTO. CITY NO. 1959
		SCALE: As Shown	DATE: 6-3-70

FED. ROAD DIST. NO.	STATE	FED. PROJ. NO.	SHEET NO.	TOTAL SHEETS
2	MD	1-95-4137136	7	13

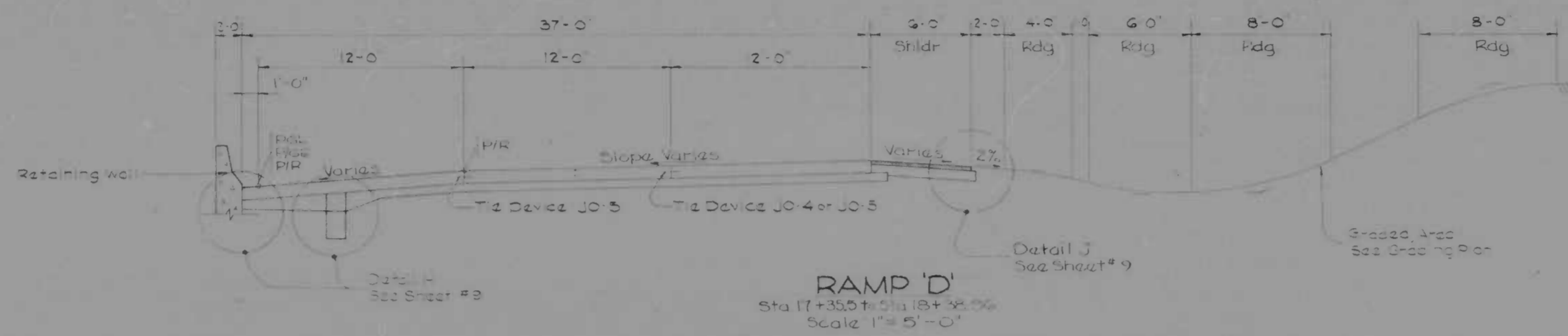

Note:
All Side Slopes - 2' Topsoil, Seed & Muck

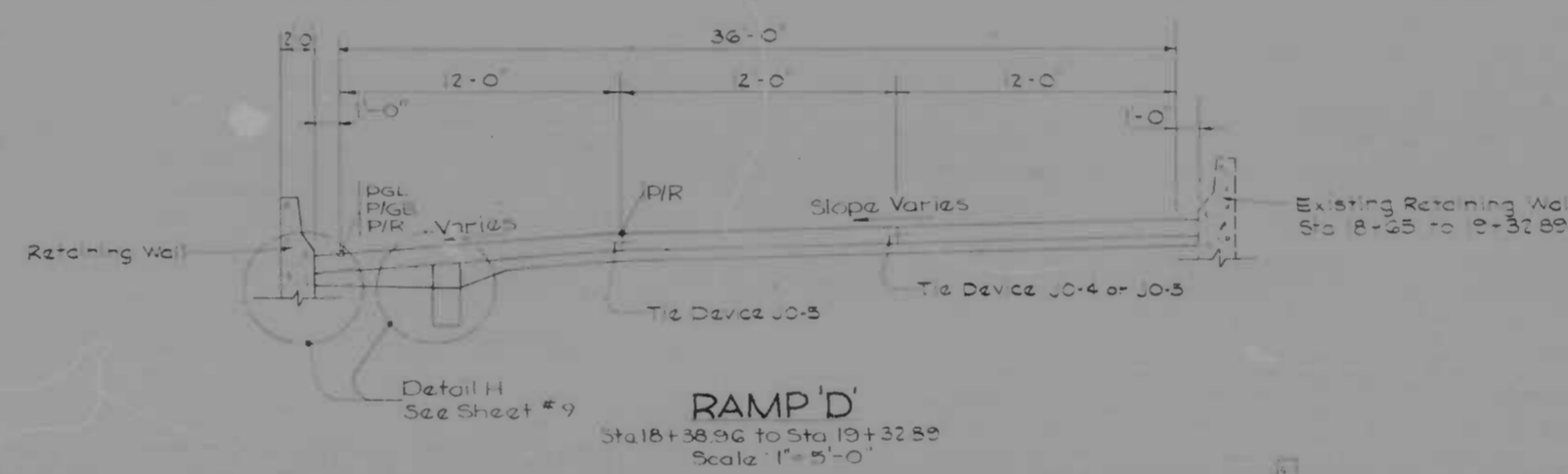

CONCRETE BARRIER
Sta 19+32.89 to Sta 20+87.87

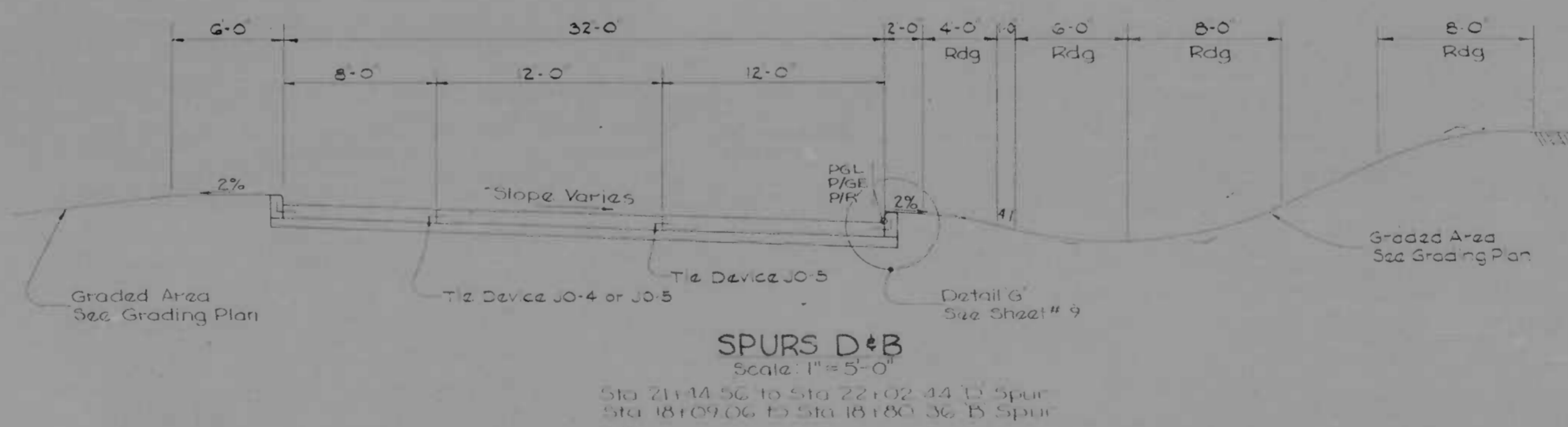

REVISIONS	CONSULTANT	CITY OF BALTIMORE DEPARTMENT OF PUBLIC WORKS &		STATE ROADS COMMISSION OF MARYLAND INTERSTATE DIVISION FOR BALTIMORE CITY	
	KIMBERLE, BENDER, STONE & ASSOC., INC.	INTERSTATE ROUTE 85		DRAWN BY: GFT	DES. BY: D.T.S.
	MATZ, CYRUS & ASSOC., INC. CONSULTING ENGINEERS 391 N. CALVERT STREET BALTIMORE, MARYLAND 21202	EASTERN AVENUE INTERCHANGE		TRACED BY: JTM	CHK. BY: S.W.T.
		SCALE: As Shown	DATE: 4-25-70	F.A.P. NO. 1-95-4137136	SHEET NO. 7 of 13

NO.	DATE	BY	CHKD.	REVISION
2	MD 1-95-413134	70	113	

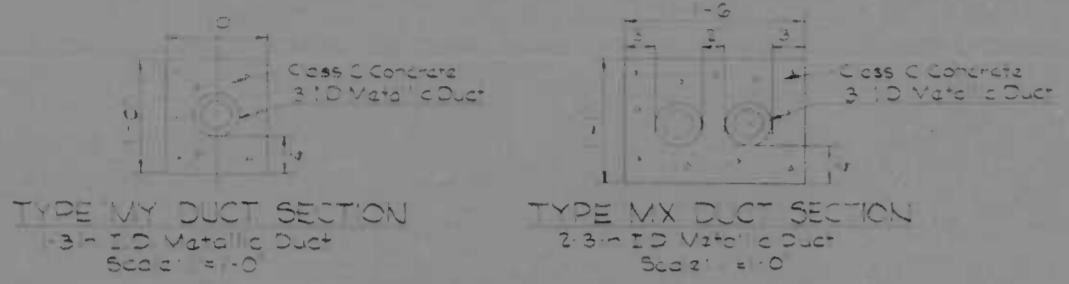

Note: See Sheet No. 70 For Shut-off Diagrams

Note: Test Pressure 150 PSI Working Pressure 50 PSI

LEGEND

- ▲ Proposed Roadway Light Standard Box (400 Watt Hg Vapor Luminaires) See Detail Sheet No. 25
- Proposed Hand Box (Metal Floor & D.T.T.) See Special Provisions
- Proposed Storm Inlet, See Spt. No. 71
- ⊙ (A) Proposed Dept. of Transit Traffic Poles, See Pole Schedule Sheet No. 71
- ⊙ (B) Proposed Dept. of Transit Traffic Production Base, See Spt. No. 71

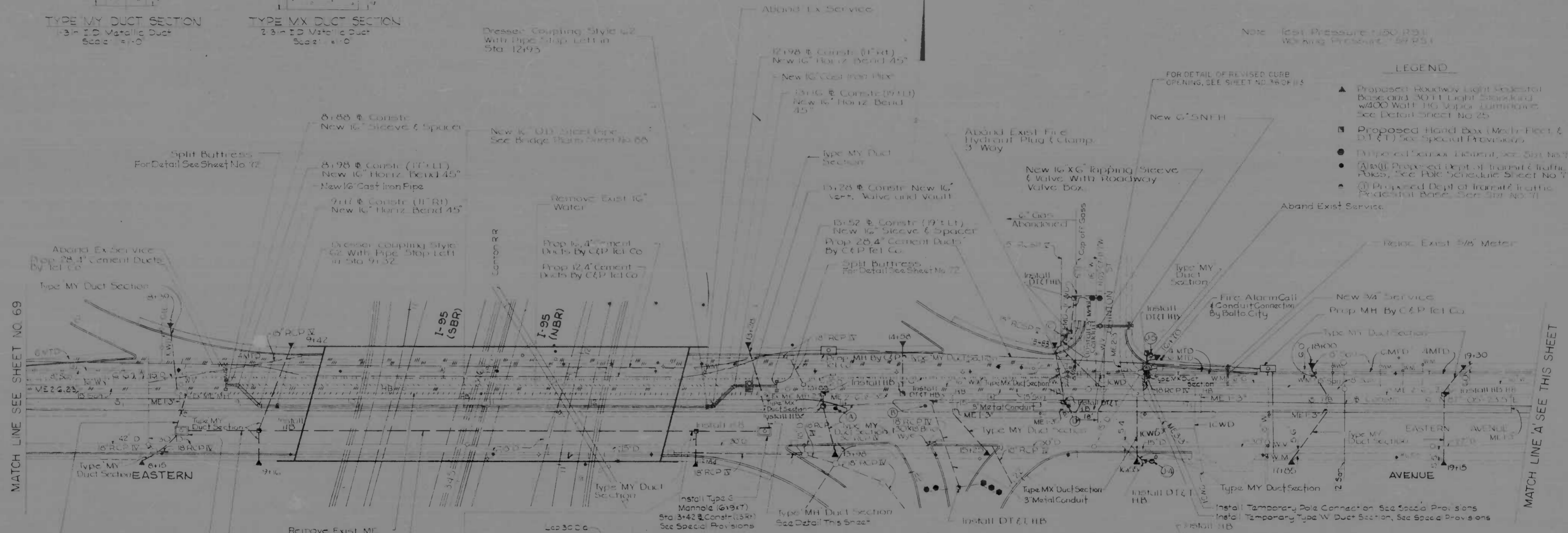

MATCH LINE SEE SHEET NO. 69

MATCH LINE 'A' SEE THIS SHEET

Remove Exist. ME
See Bridge Plans for Conduit Section Sheet No. 85
Transition from Bridge Duct Section to Type MH Duct Section to be Paid for per Linear Foot of Type MH Duct Section
Install Type C Manhole (C-917) 24" 8'42" Constr. (19'11") See Special Provisions

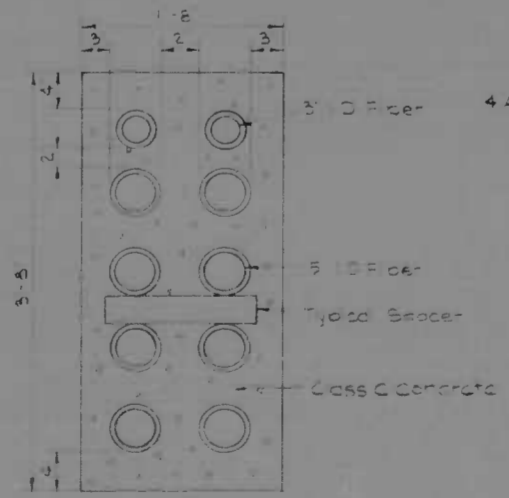

TYPE MH DUCT SECTION
5.5" O.D. Spacing 2.5" O.D. Spacing
MODIFIED DUCT SECTION
Scale: 1"=1'-0"

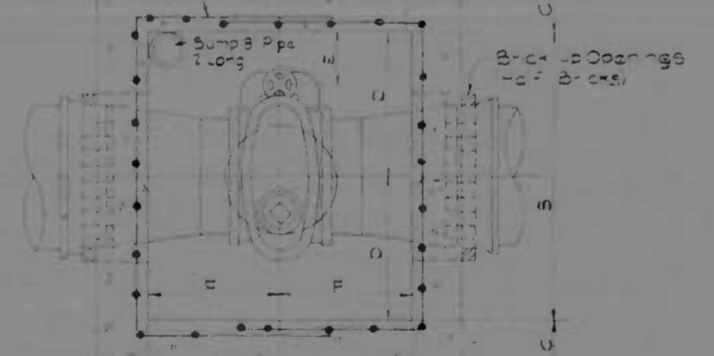

VALVE AND VAULT
Not to Scale

Size of Valve		Size of Box		Spacing		5" Right Bars		Concrete		Comp. Per	
A	B	C	D	E	F	G	H	I	J	K	L
3	3	3	3	3	3	3	3	3	3	3	3
3	3	3	3	3	3	3	3	3	3	3	3

Roof Slab Materials
 * All Bars to Extend 3' over inside edge of wall

REVISIONS 1. REV. 11-20-95, Section 8, Paragraph 3-3-95	CONSULTANT KNOX, BENDER, STONE & ALCO, INC. 341 N. CALVERT STREET BALTIMORE, MARYLAND 21202	CITY OF BALTIMORE DEPARTMENT OF PUBLIC WORKS INTERSTATE ROUTE 95 EASTERN AVENUE INTERCHANGE	STATE ROADS COMMISSION OF MARYLAND INTERSTATE DIVISION FOR BALTIMORE CITY	
			DRAWN BY: JJK TRACED BY: JJK P.A.P. NO. 1-95-413134 S.R.C. NO. 80-245-29-85 BALTO. CITY NO. 1189	DES. BY: VFN P.A.P. BY: DES SHEET NO. 70 OF 113
SCALE: 1"=40' DATE: 4-27-70				

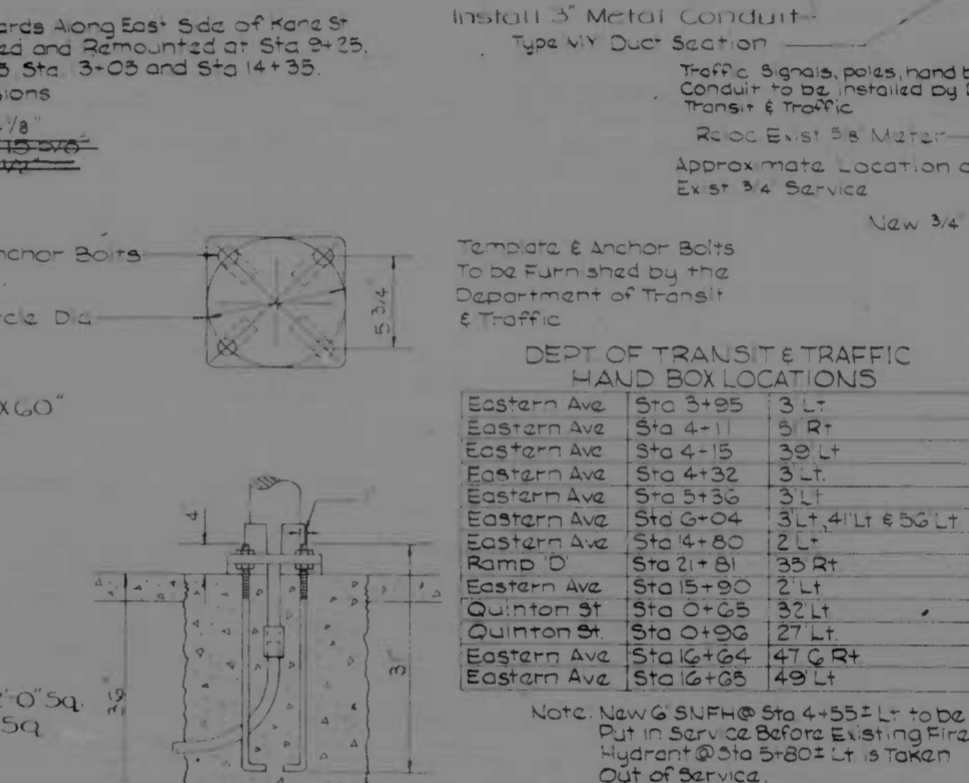
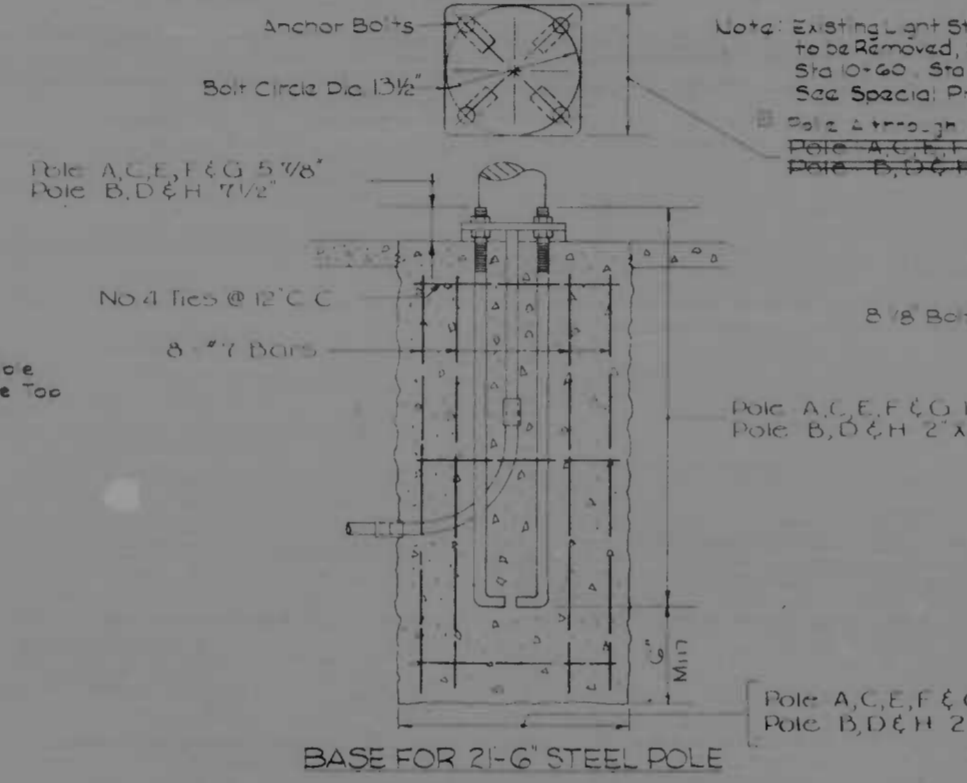
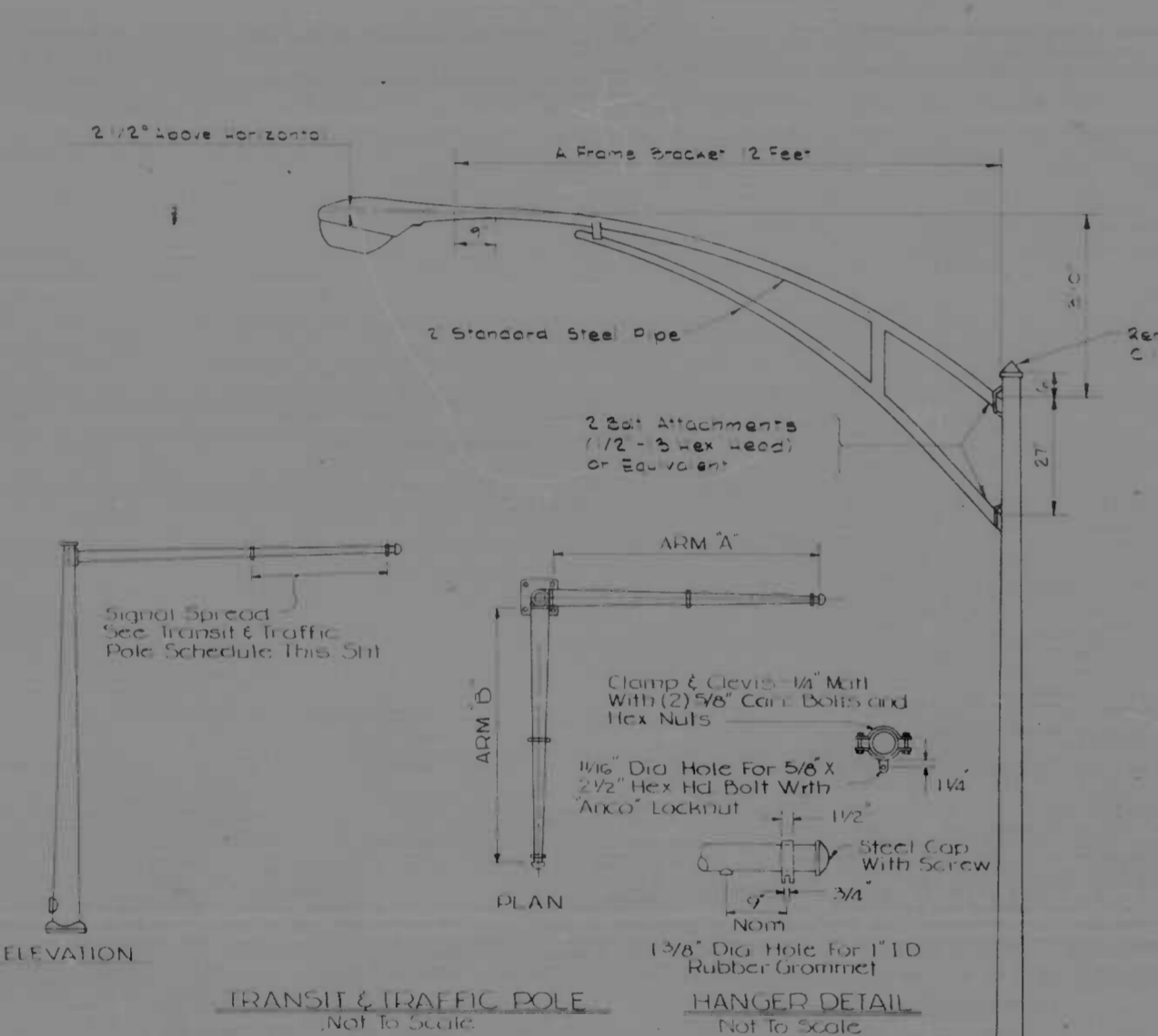
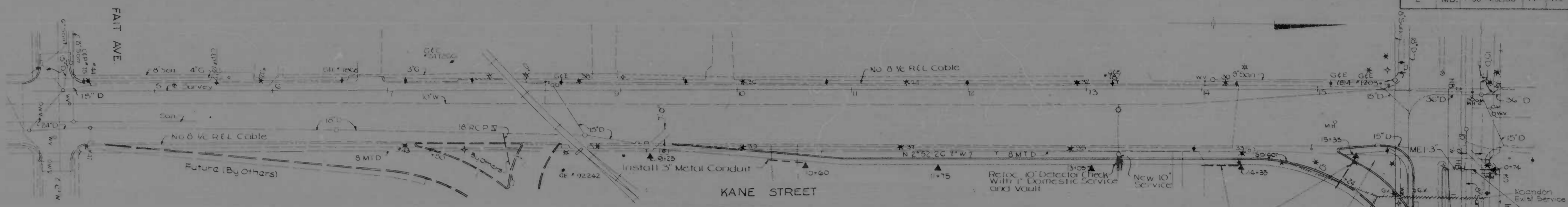

TRANSIT & TRAFFIC POLE SCHEDULE

POLE IDENT	POLE SIZE	TRAFFIC ARMS ARM 'A'	TRAFFIC ARMS ARM 'B'	SIGNAL SPREAD	LOCATION
A	21' 6"	30"	14"	14"	Eastern Ave Sta 3+97 2R
B	21' 6"	24"	14"	14"	Eastern Ave Sta 4+75 ON R
D	21' 6"	20"	24"	15 Signal	Quinton St Eastern Ave Sta 0+21 3S Lt
E	21' 6"	20"	22"	14"	Eastern Ave Sta 3+90 ON R
F	21' 6"	22"	14"	14"	Eastern Ave Sta 4+40 ON R
G	21' 6"	22"	14"	14"	Eastern Ave Sta 5+38 ON R
H	21' 6"	30"	22"	14"	Eastern Ave Sta 6+29 ON R

PEDESTAL BASE LOCATIONS

J-1	Eastern Ave	Sta 4+04	3 R
J-2	Eastern Ave	Sta 4+19	39 Lt
J-3	Eastern Ave	Sta 5+97	36 Lt
J-4	Eastern Ave	Sta 6-38	47E Rt
J-5	Eastern Ave	Sta 6+29	48 Lt

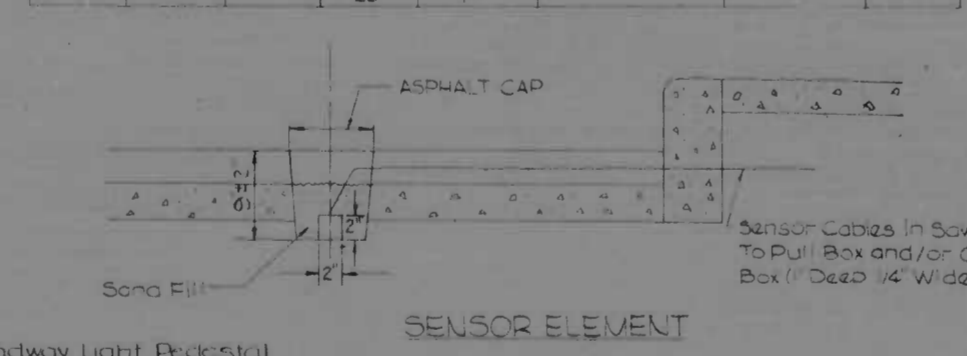
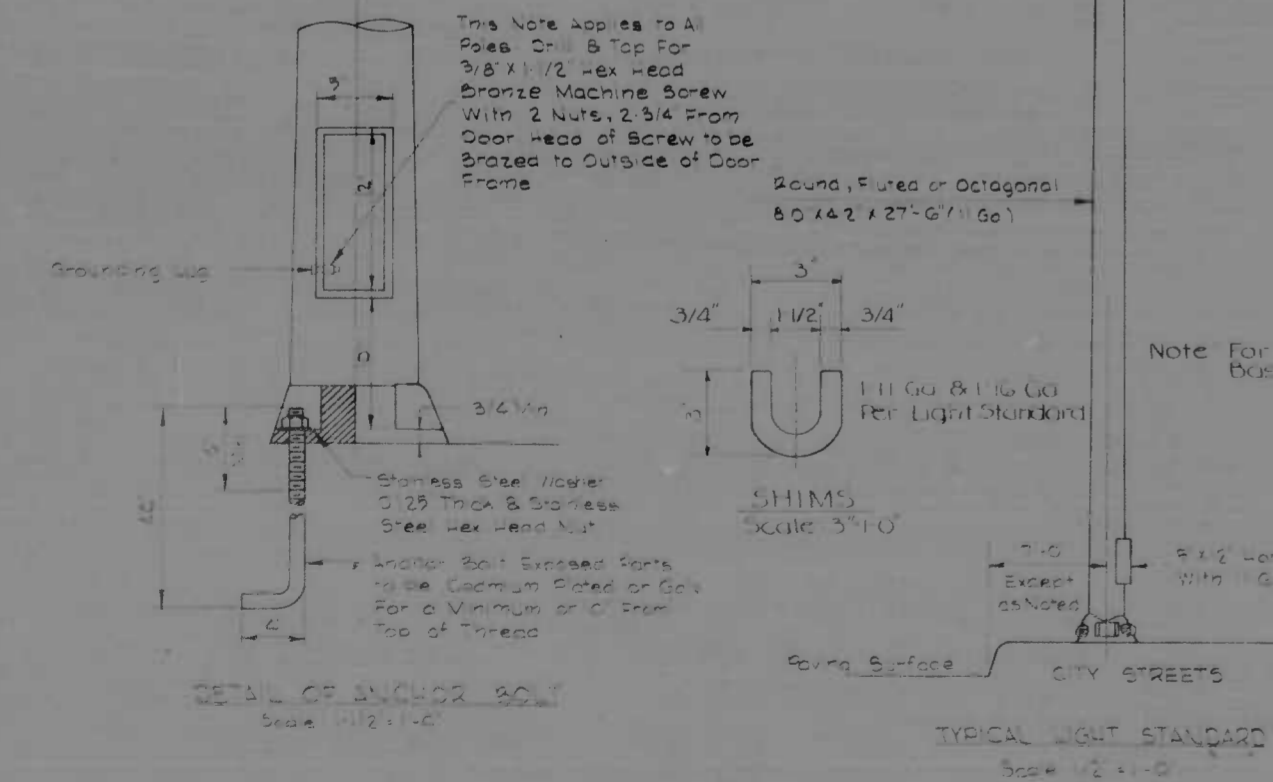

SENSOR ELEMENT LOCATIONS

RAVMP	Sta	8 Rt & 12 Rt
RAVMP B	Sta 18+43	8 Rt & 12 Rt
RAVMP B	Sta 18+52	8 Lt, 16 Lt & 24 Lt
RAVMP D	Sta 21+81	8 Rt & 16 Rt
RAVMP D	Sta 21+75	8 Lt, 16 Lt & 24 Lt
RAVMP D	Sta 21+75	8 Lt, 16 Lt & 24 Lt
Quinton St	Sta 0+95	7 Lt & 13 Lt

LEGEND

- ▲ Proposed Roadway Light Pedestal Base and 30 Ft Light Standard w/400 Watt HG Vapor Luminaires. See Detail Sheet No 25 & this Sheet
- Proposed Hand Box (Mech-Elect & DT & T) See Special Provisions
- Proposed Sensor Element, See Detail This Sheet
- ⓐ to ⓓ Proposed Dept of Transit & Traffic Steel Poles, See Pole Schedule This Sheet
- ⓔ Proposed Dept of Transit & Traffic Pedestal, See Detail This Sheet

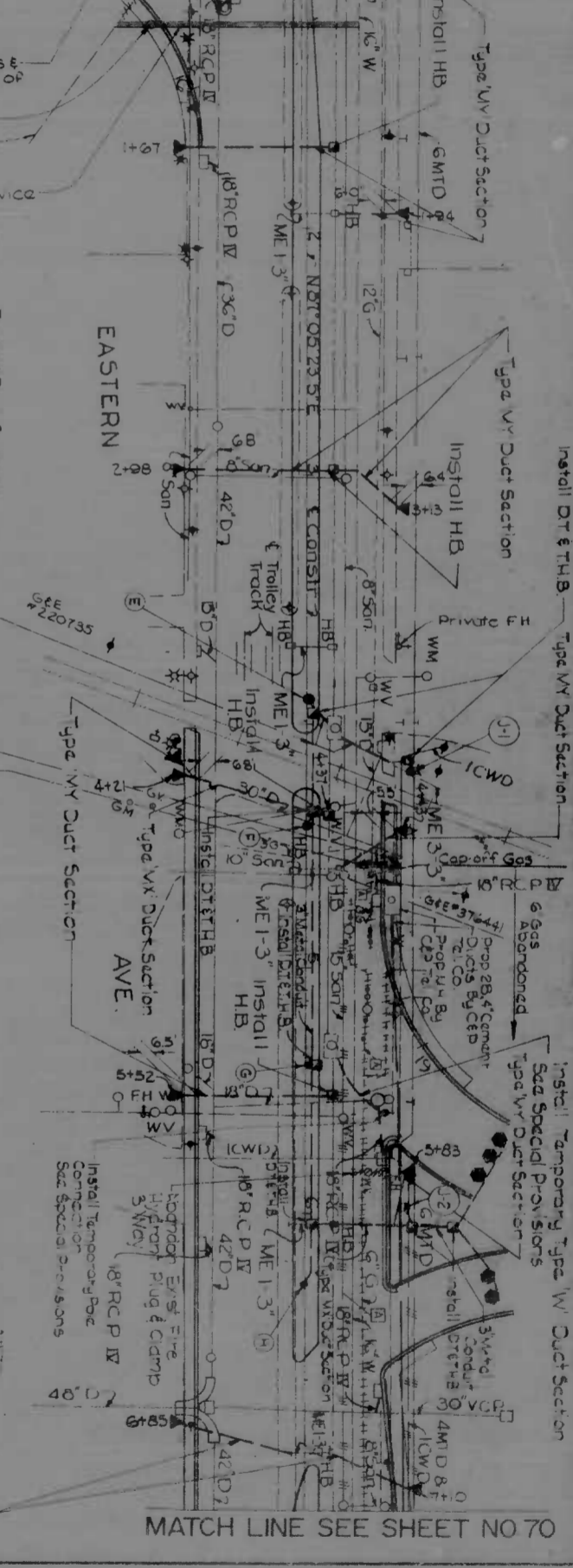

REVISIONS Revised Base Plate 9/21/71	CONSULTANT KNOERLE, BENDER, STONE & ASSOC., INC. AND MATZ, CHILDS & ASSOC., INC. CONSULTING ENGINEERS 341 N. CALVERT STREET BALTIMORE, MARYLAND 21202	CITY OF BALTIMORE DEPARTMENT OF PUBLIC WORKS		STATE ROADS COMMISSION OF MARYLAND INTERSTATE DIVISION FOR BALTIMORE CITY	
		INTERSTATE ROUTE 95 EASTERN AVENUE INTERCHANGE		DRAWN BY: JJK TRACED BY: JJK	DES BY: VEH CHK BY: DES
SCALE: 1" = 40' DATE: 4-27-70		F.A.P. NO. 1-95-4132136 S.R.C. NO. BC246-29-95 BALTO. CITY NO. 1959		SHEET NO. 71 OF 113	

FED. ROAD DIST. NO.	STATE	PROJECT NO.	SHEET NO.	TOTAL SHEETS
2	MD.	1-95-4132136	72	113

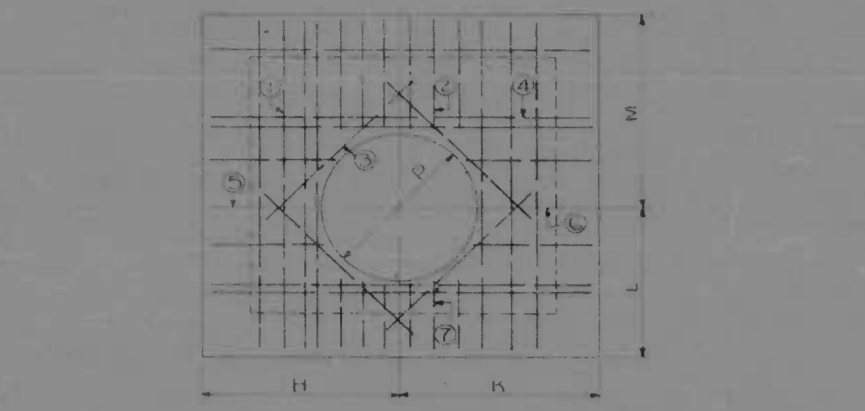

LOADING	SIZE OF BARS	SPACING	STRAIGHT BARS	CONCRETE QUANTITY
10' ROADWAY	9"	5"	1 2 3 4 5 6 7 8 9 10 11 12 13 14 15 16 17 18 19 20 21 22 23 24 25 26 27 28 29 30 31 32 33 34 35 36 37 38 39 40 41 42 43 44 45 46 47 48 49 50 51 52 53 54 55 56 57 58 59 60 61 62 63 64 65 66 67 68 69 70 71 72 73 74 75 76 77 78 79 80 81 82 83 84 85 86 87 88 89 90 91 92 93 94 95 96 97 98 99 100	1.29 cu yds

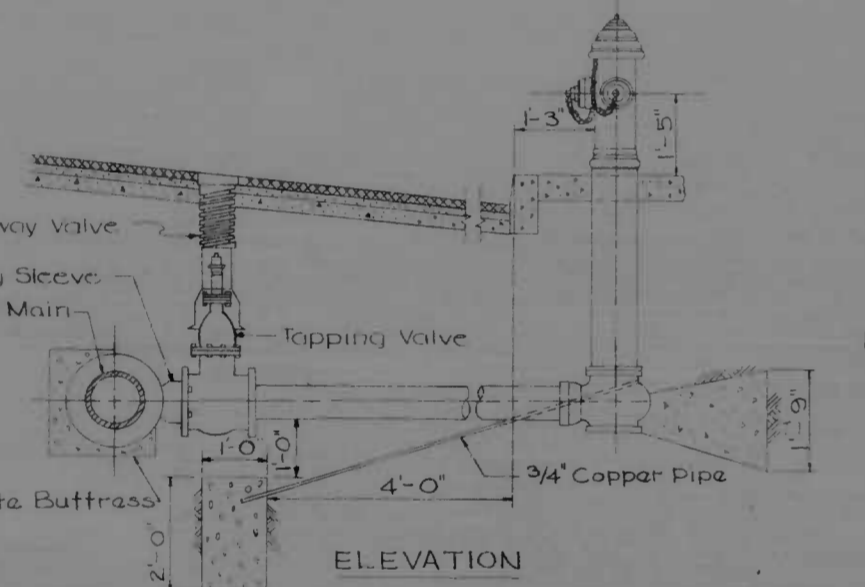
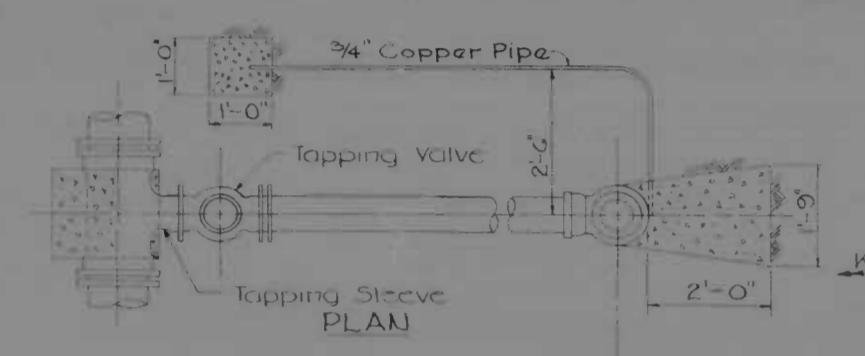

STANDARD BUTTRESS FOR G\"/>

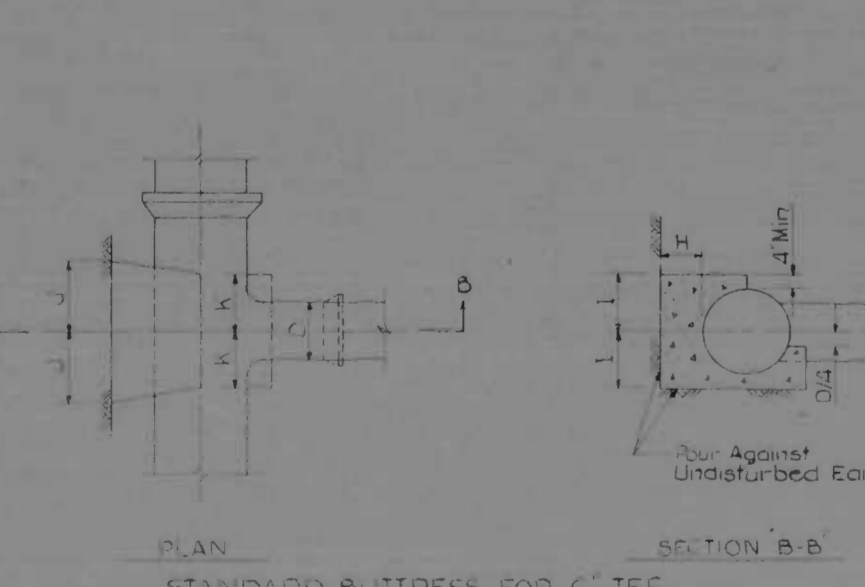

Size of Branch	H	I	J	K
6"	5"	1'-0"	6"	5"

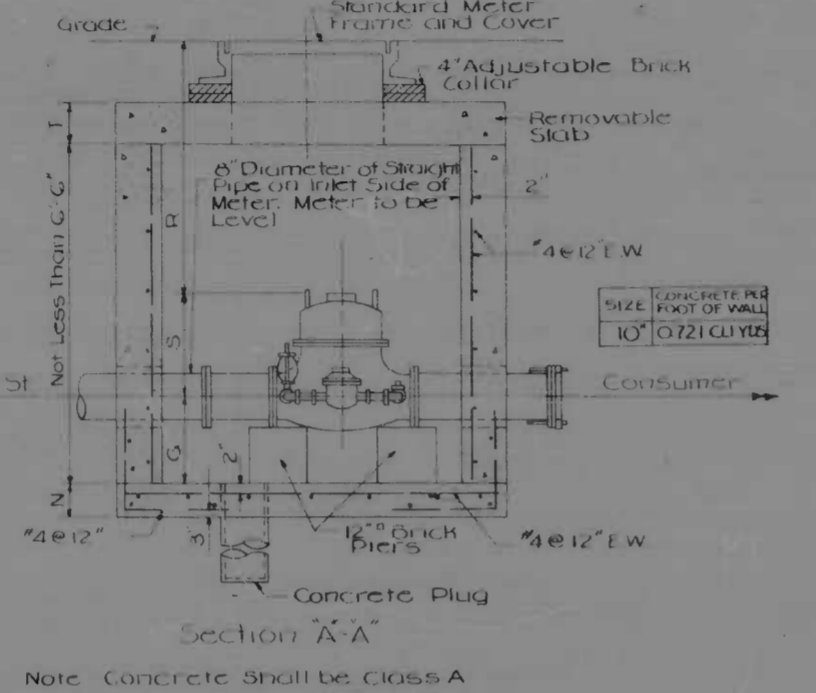
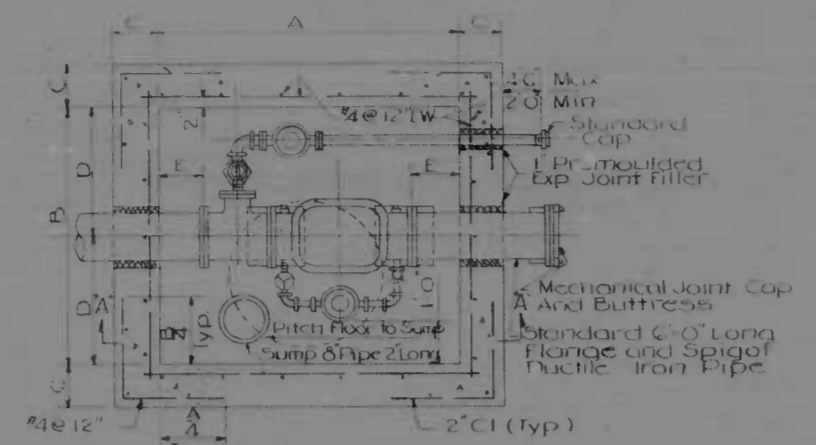

SHUTOFF DIAGRAM See Special Provisions

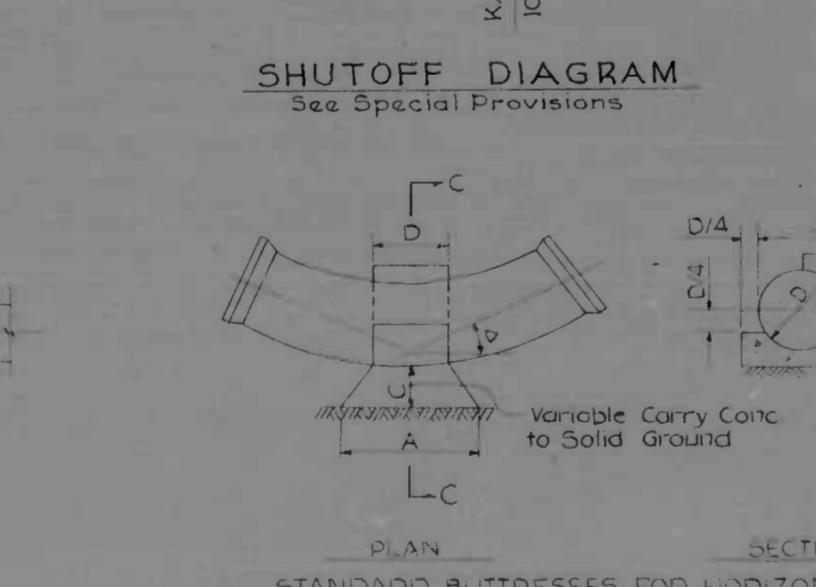
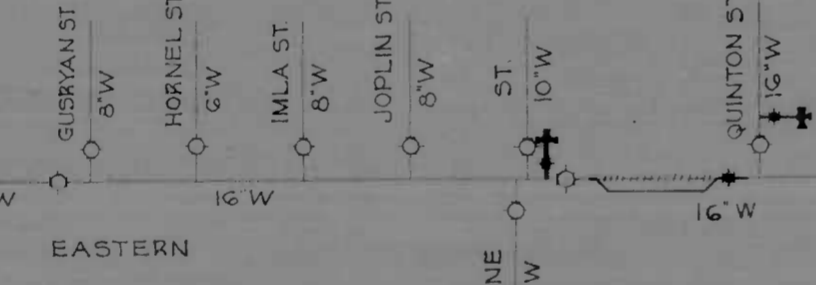

Size of Branch	A	B	C
16"	45"	2'-5"	1'-3"

SIZE	10'
A	6.4
B	5.2
C	9
D	2.7
E	9
F	2.4
G	4.0
H	4.0
I	4.0
J	3.6
K	3.6
L	3.6
M	3.6
N	3.6
O	3.6
P	3.6
Q	3.6
R	3.6
S	3.6

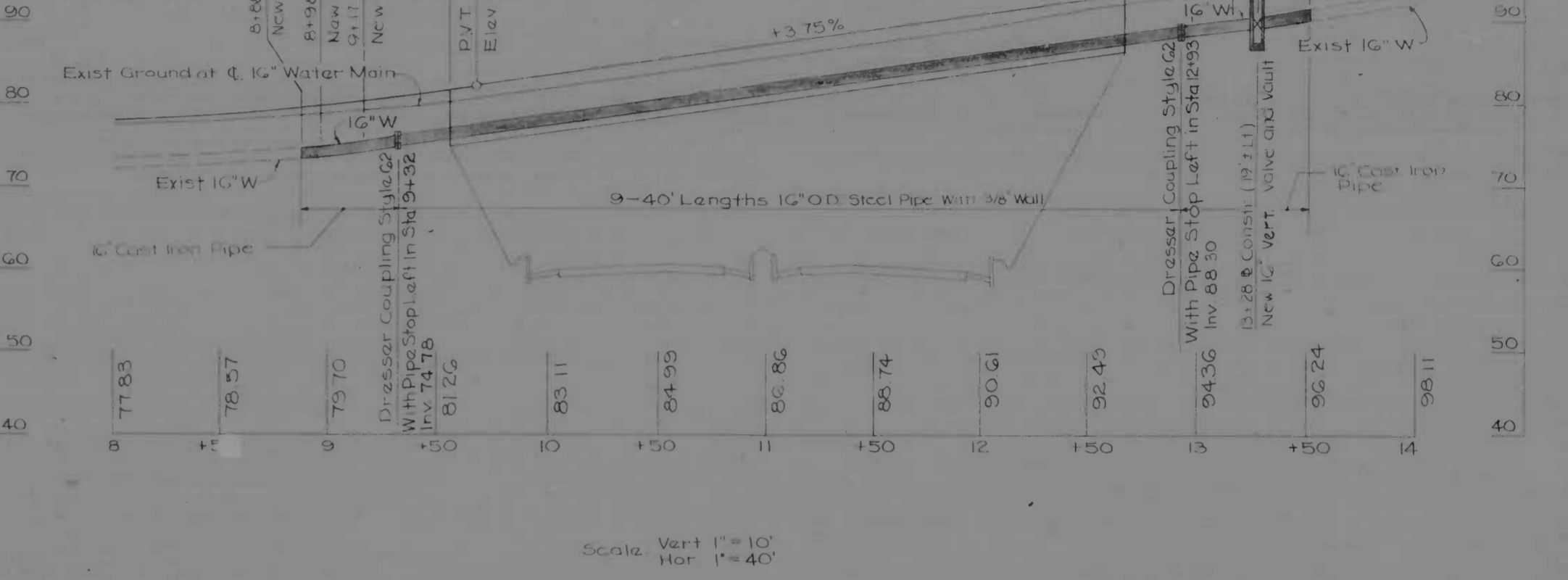

Scale: Vert 1" = 10', Hor 1" = 40'

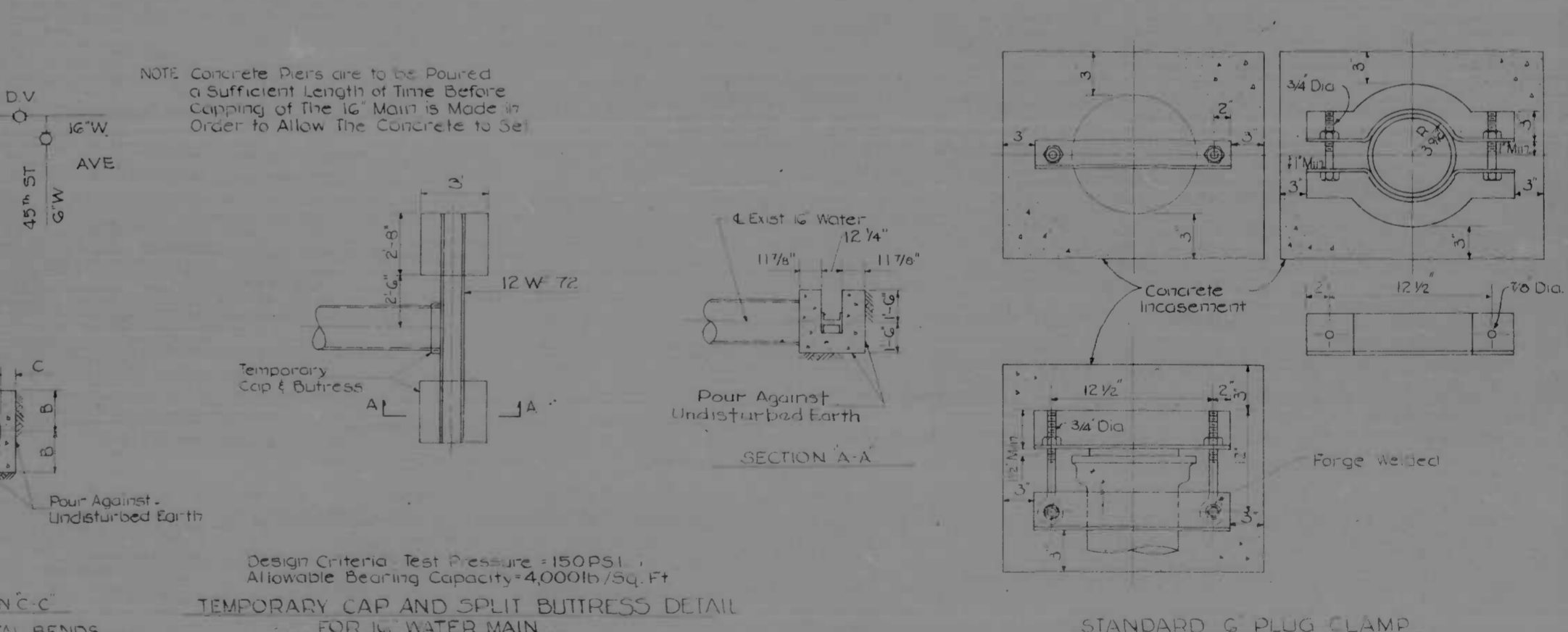

REVISIONS	CONSULTANT	CITY OF BALTIMORE DEPARTMENT OF PUBLIC WORKS	STATE ROADS COMMISSION OF MARYLAND INTERSTATE DIVISION FOR BALTIMORE CITY
	KNOEHL, BENDER, STONE & ASSOC., INC. AND WATZ, CHILES & ASSOC., INC. CONSULTING ENGINEERS	INTERSTATE ROUTE 95 EASTERN AVENUE INTERCHANGE	DRAWN BY W.F.F. TRACED BY J.H.K. DES. BY W.F.F. CHK. BY D.E.S.
		SCALE: AS SHOWN	SHEET NO. 72 OF 113

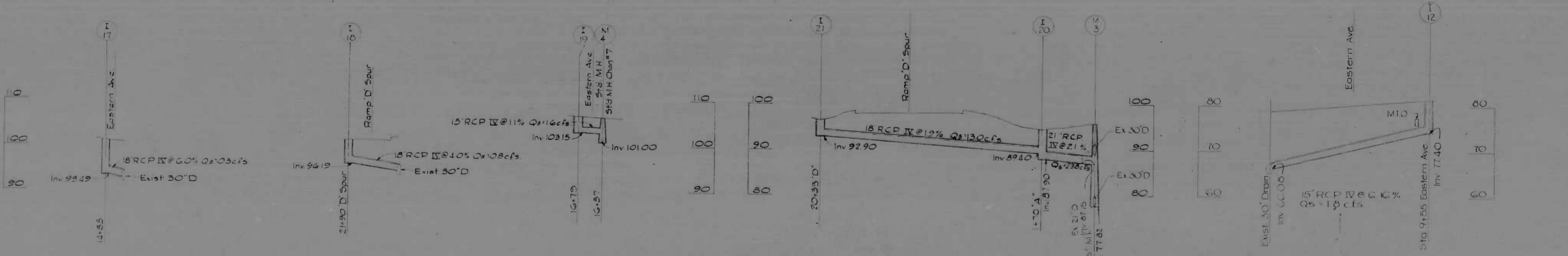
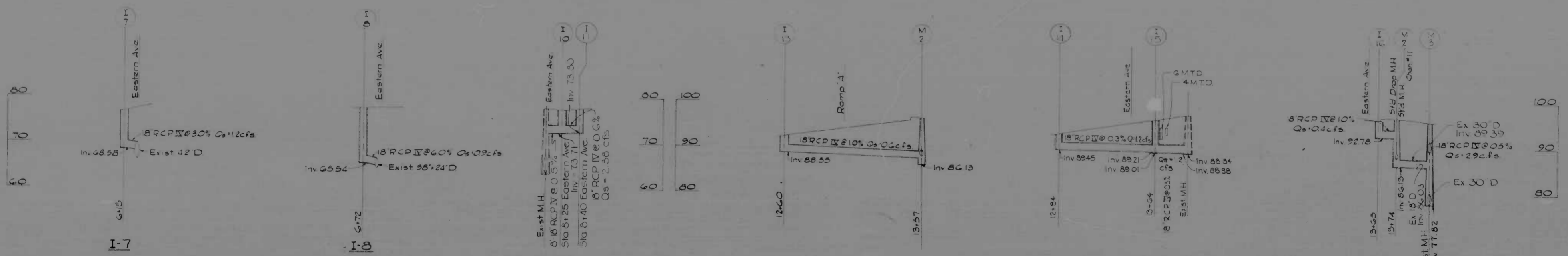
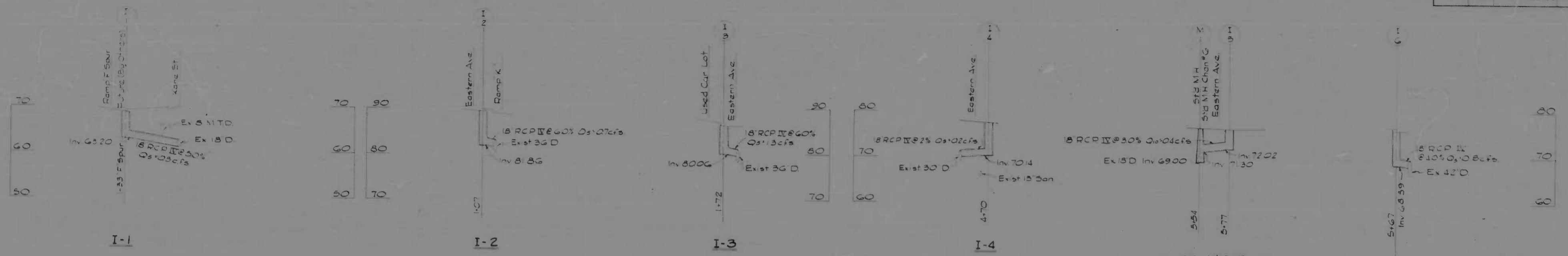

REVISIONS	CONSULTANT	CITY OF BALTIMORE DEPARTMENT OF PUBLIC WORKS & STATE ROADS COMMISSION OF MARYLAND INTERSTATE DIVISION FOR BALTIMORE CITY	
	KNORRLE, BENDER, STONE & ASSOC., INC. AND MATZ, CHILDS & ASSOC., INC. CONSULTING ENGINEERS 341 N. CALVERT STREET BALTIMORE, MARYLAND 21202	INTERSTATE ROUTE 95 EASTERN AVENUE INTERCHANGE	
		SCALE: Hor. 1"=40', Vert. 1"=10'	DATE: 6-3-70
		DRAWN BY: C.E.P. TRACED BY: M.E.H.	DES. BY: C.E.P. CHK. BY: C.E.S.
		F.A.P. NO. 1-95-4(32)36 S.R.C. NO. BC 246-29-815	SHEET NO. 73 OF 113

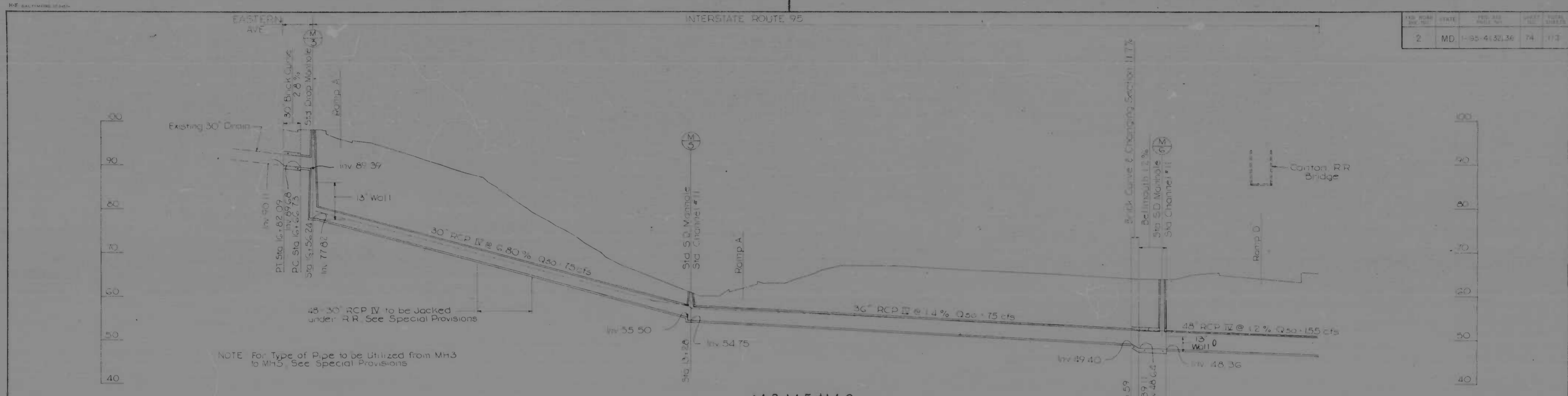

NOTE: For Type of Pipe to be Utilized from MH3 to MH5, See Special Provisions

M-3, M-5, & M-6

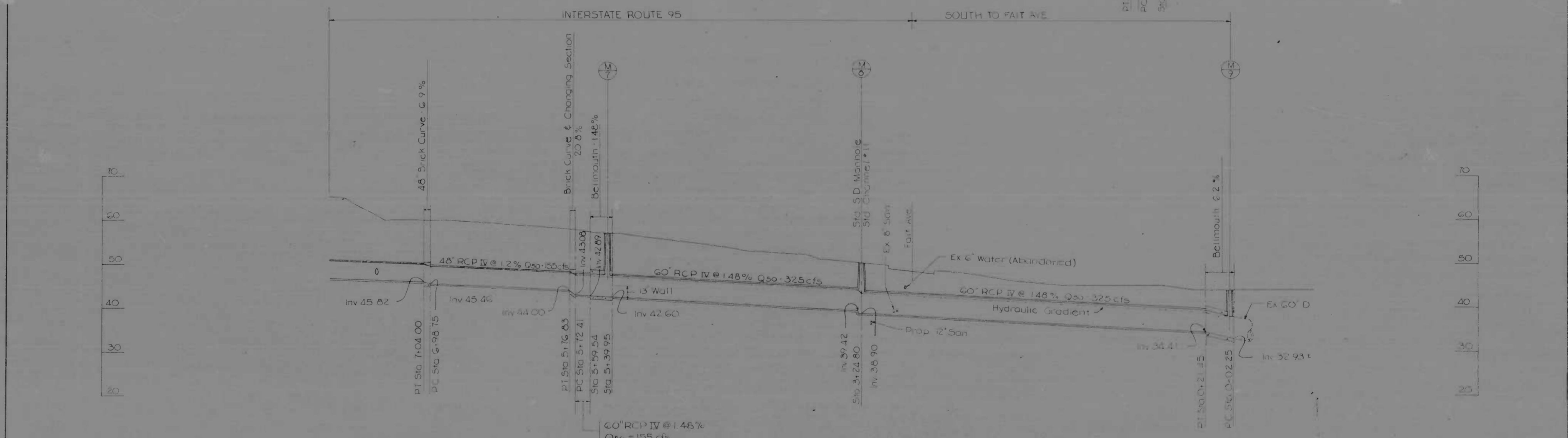

M-7, M-8, & M-9

REVISIONS	CONSULTANT	CITY OF BALTIMORE DEPARTMENT OF PUBLIC WORKS	STATE ROADS COMMISSION OF MARYLAND INTERSTATE DIVISION FOR BALTIMORE CITY
	KNORRLE, BENDER, STONE & ASSOC., INC. AND WATZ, PHILIPS & ASSOC., INC. CONSULTING ENGINEERS 341 N. CALVERT STREET BALTIMORE, MARYLAND 21202	INTERSTATE ROUTE 95 EASTERN AVENUE INTERCHANGE	DRAWN BY: CFP TRACED BY: JPK F.A.P. NO.: 1132-312038 S.R.C. NO.: BC 245-28-R-4 BALTO. CITY NO.: 1959
		SCALE: 1" = 40' HORIZ. 1" = 10' VERT. DATE: 10-8-59	DES. BY: CFP CHK. BY: DES SHEET NO.: 74 OF 113

FED. ROAD DIST. NO.	STATE	FED. AID PROJ. NO.	SHEET NO.	TOTAL SHEETS
2	MD.	1-95-4(32)36	75	113

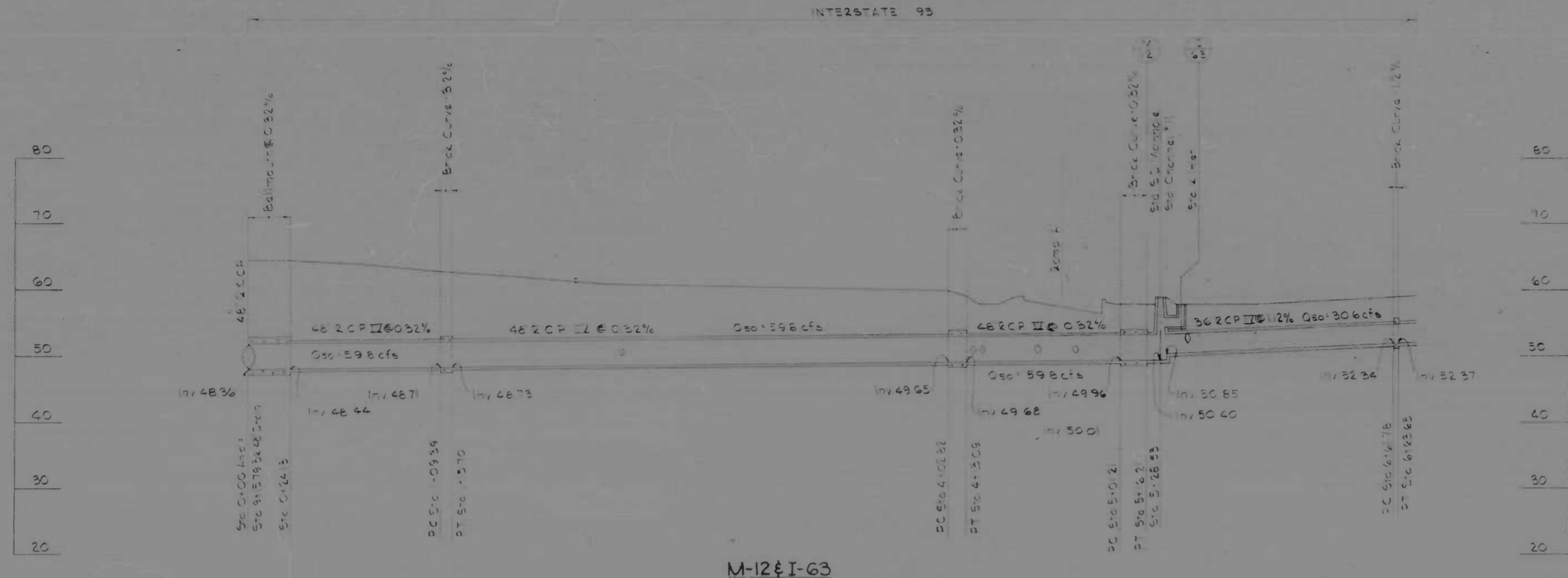

M-12 & I-63

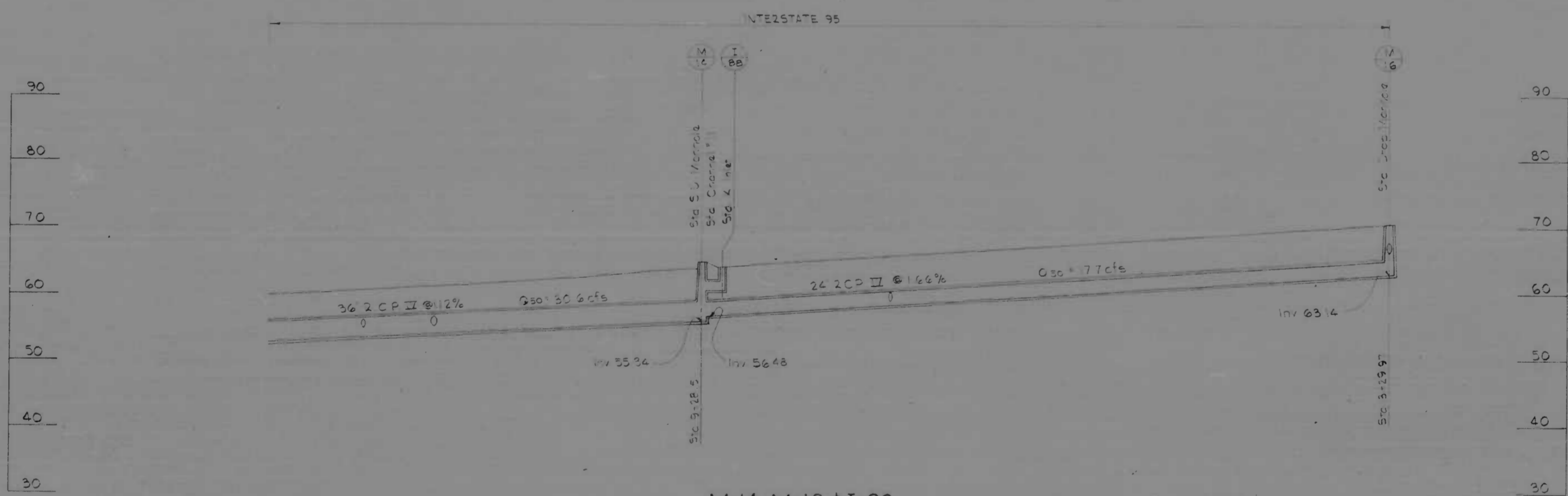

M-14, M-16 & I-88

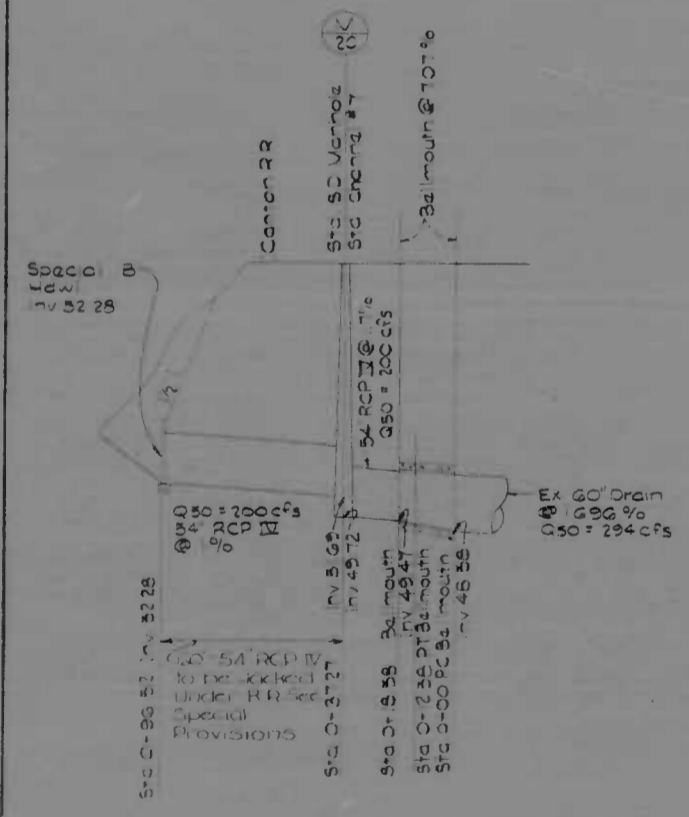

REVISIONS	CONSULTANT	CITY OF BALTIMORE DEPARTMENT OF PUBLIC WORKS	STATE ROADS COMMISSION OF MARYLAND INTERSTATE DIVISION FOR BALTIMORE CITY
	KNORRLE, BENDER, STONE & ASSOC., INC. AND MATZ, CHURS & ASSOC., INC. CONSULTING ENGINEERS 341 N. CALVERT STREET BALTIMORE, MARYLAND 21202	INTERSTATE ROUTE 95 EASTERN AVENUE INTERCHANGE	DRAWN BY: CEP TRACED BY: AGB F.A.P. NO. 35-4(32)36 S.R.C. NO. BC 246-29-815 BALTO CITY NO. 1959
		SCALE: 1"=40' Horizontal, 1"=10' Vertical	DATE: 4-27-70
			SHEET NO. 75 OF 113

REV.	DATE	BY	DESCRIPTION
2	MD	1-95-4132136	76 of 113

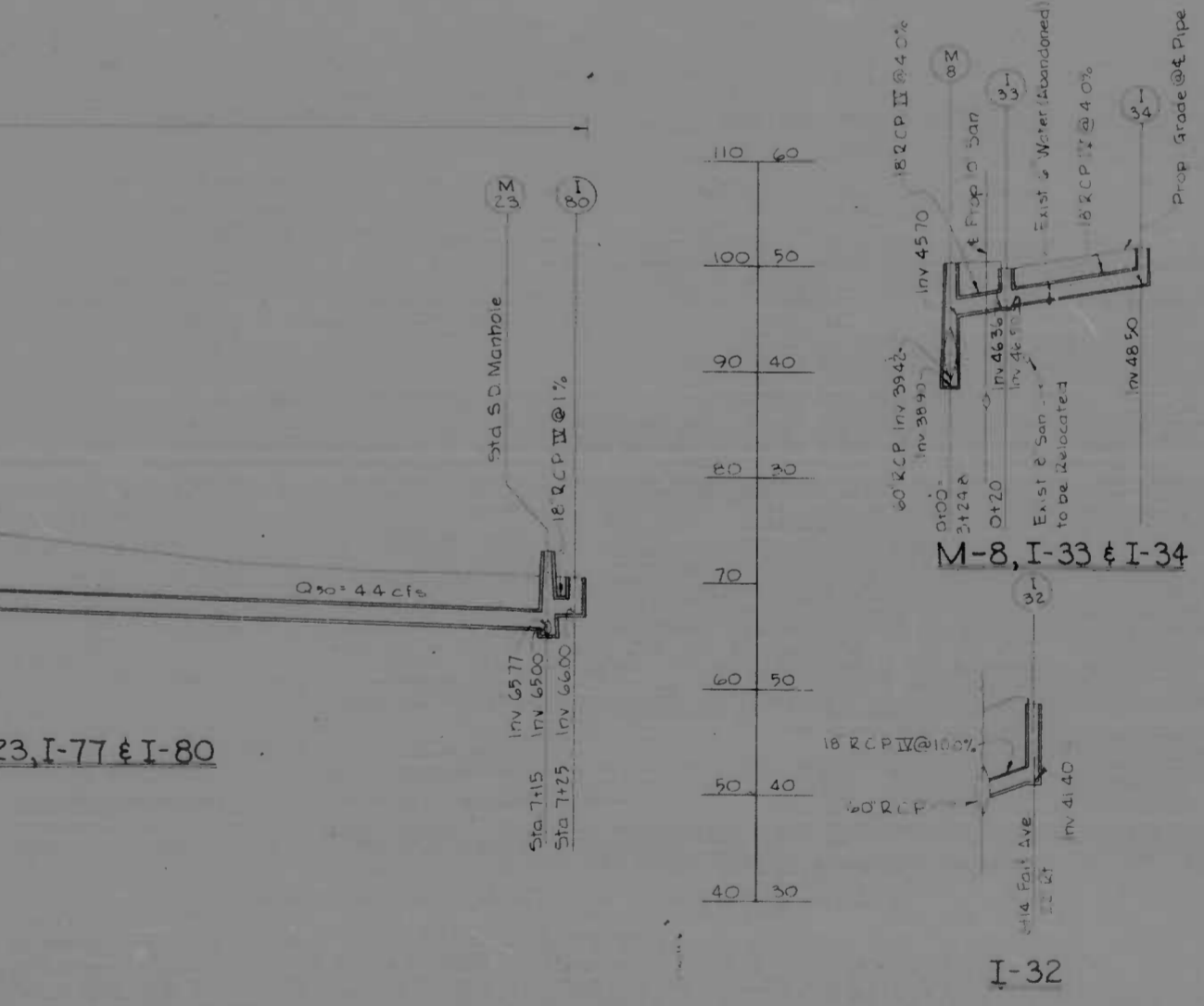
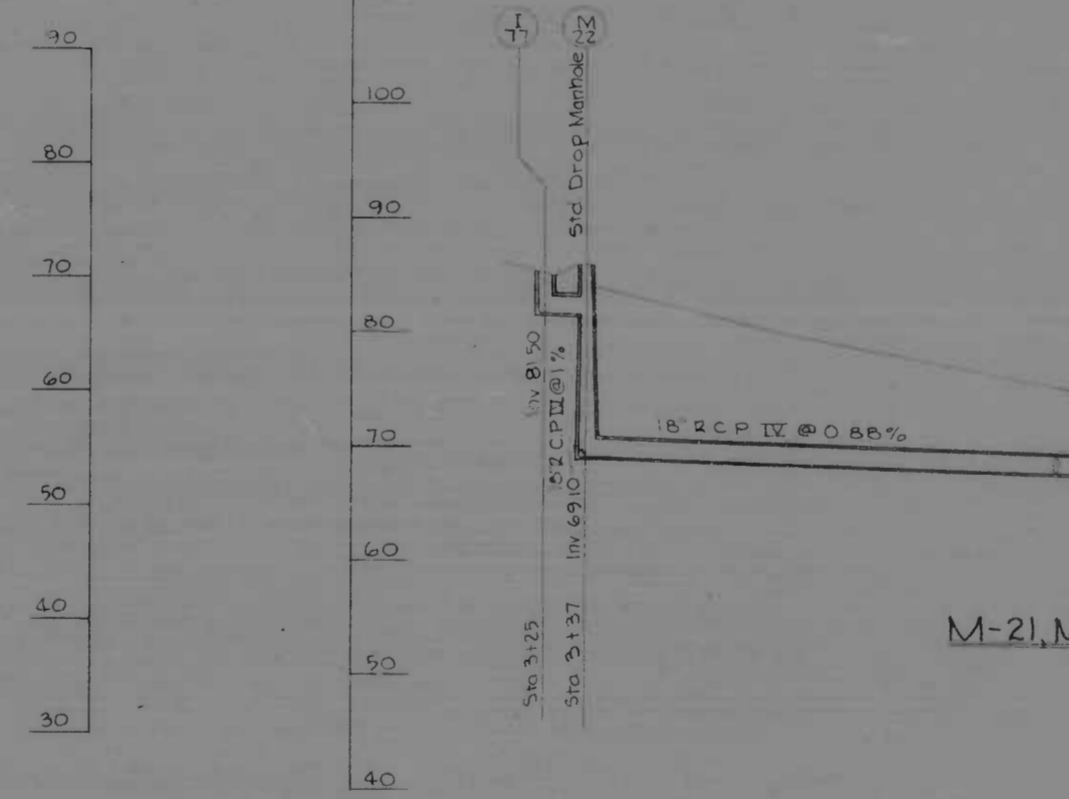
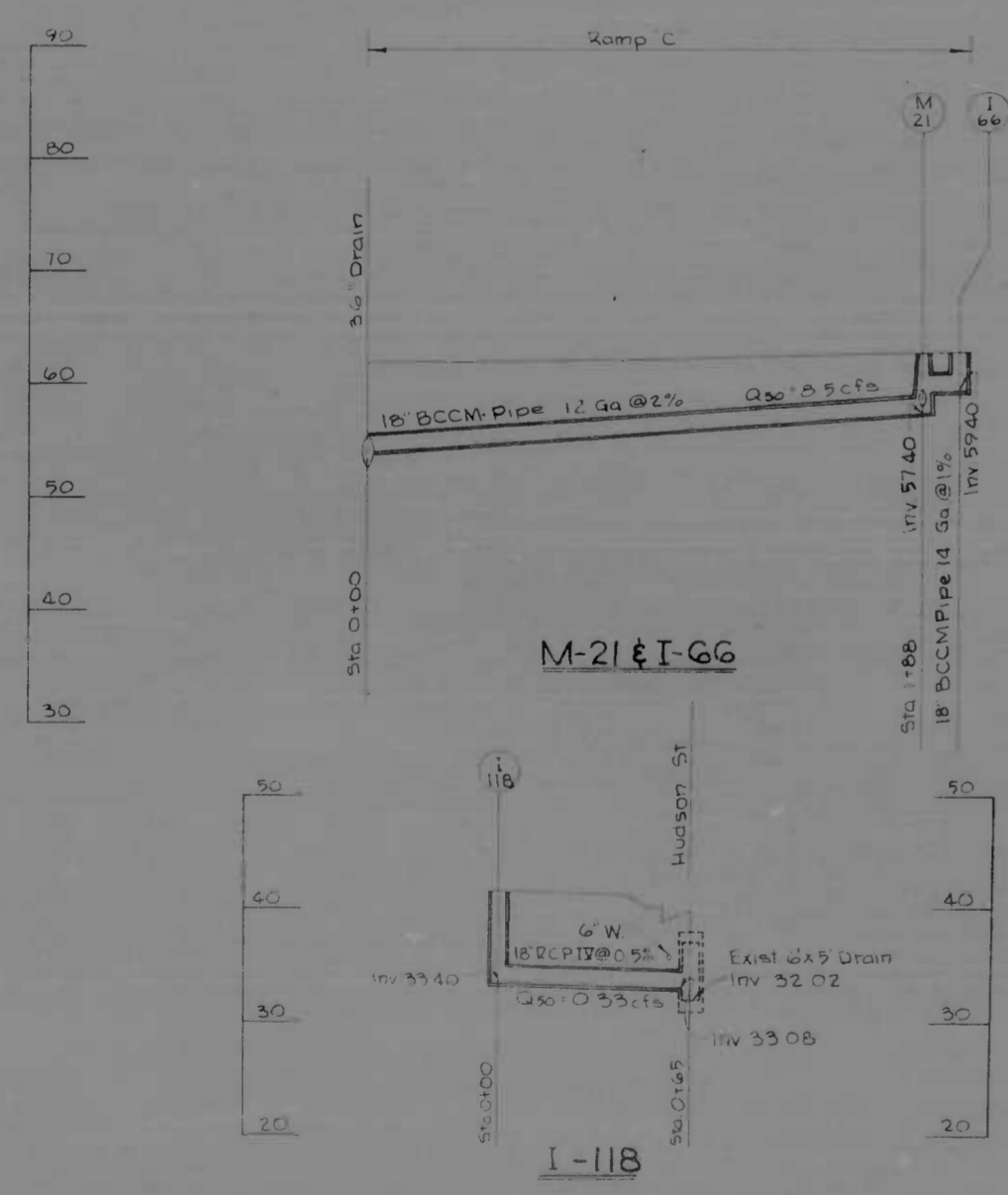
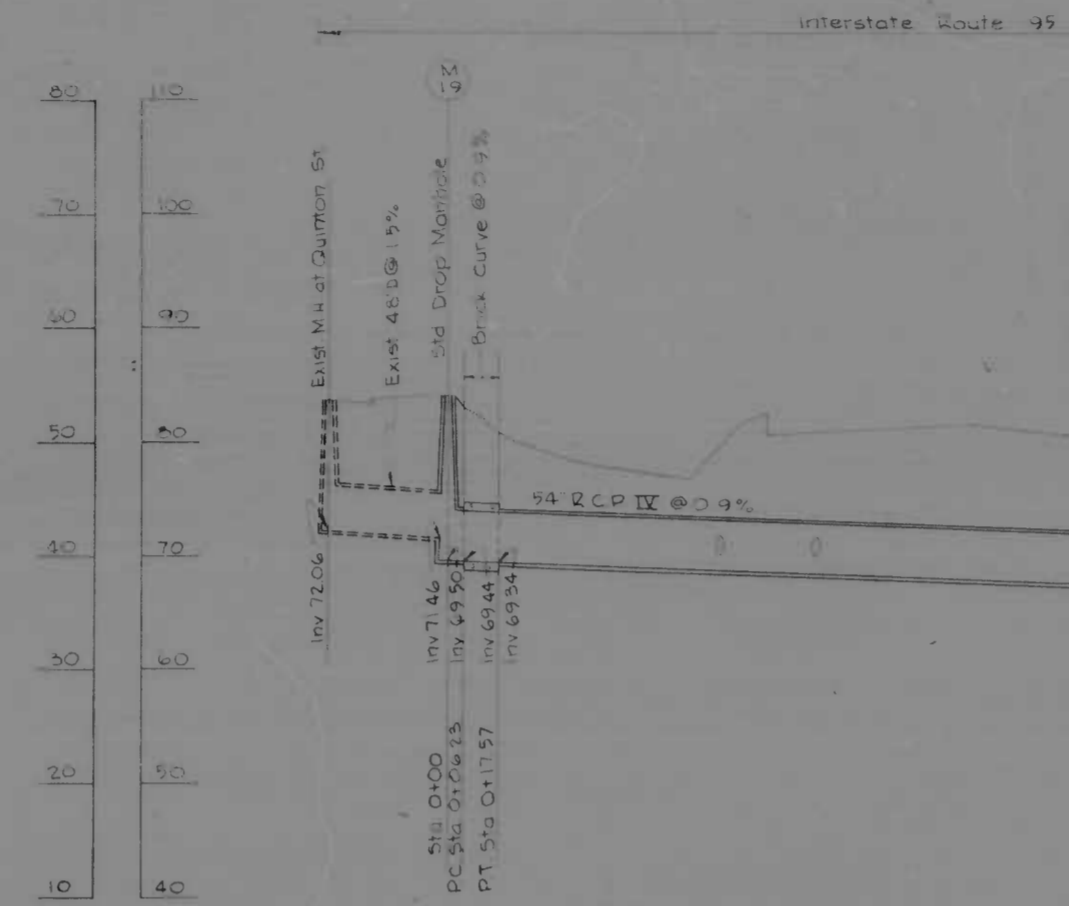
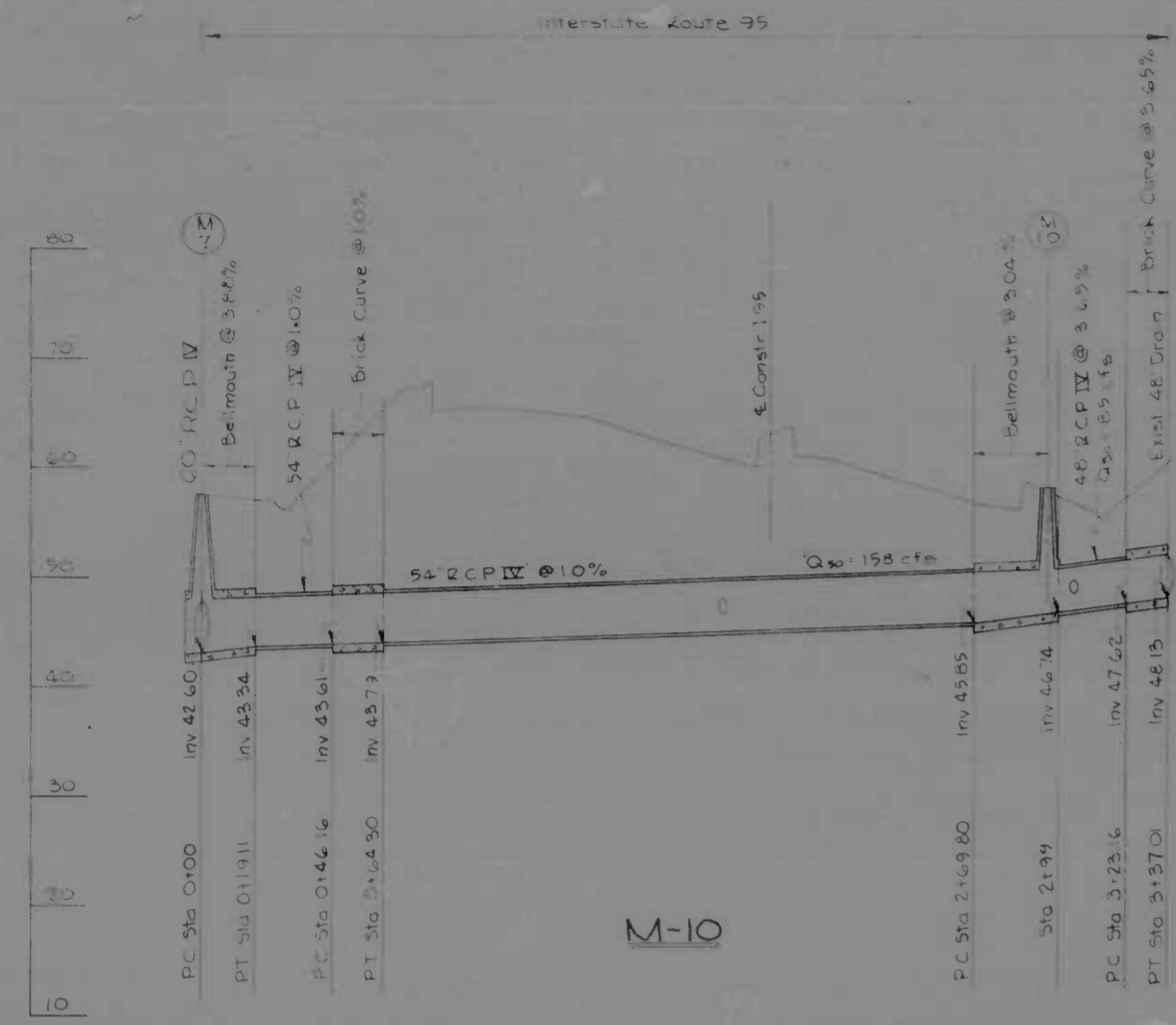

REVISIONS	CONSULTANT	CITY OF BALTIMORE DEPARTMENT OF PUBLIC WORKS	STATE ROADS COMMISSION OF MARYLAND INTERSTATE DIVISION FOR BALTIMORE CITY
	ENGINEER, BENDER, STONE & ASSOC., INC. MATZ CHILDS & ASSOC., INC. CONSULTING ENGINEERS 941 N. CALVERT STREET BALTIMORE, MARYLAND 21202	INTERSTATE ROUTE 95 EASTERN AVENUE INTERCHANGE	DRAWN BY CEP TRACED BY ACB F.A.P. NO. 1-95-4132136 S.R.C. NO. 86 246-29-815 BALTO. CITY NO. 1959
		SCALE: 1" = 40' Horizontal, 1" = 10' Vertical	DATE: 4-27-70
			SHEET NO. 76 of 113

FILE NO.	DATE	REV. NO.	BY	CHKD.
2	MD	I-95-4(32)36	77	113

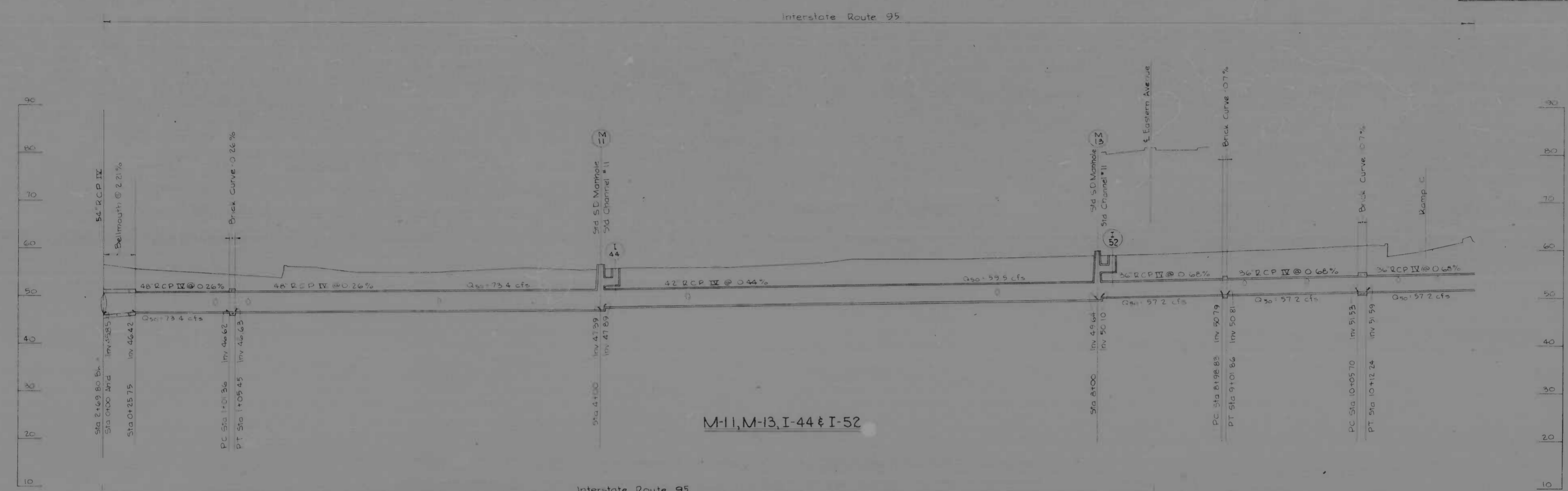

M-11, M-13, I-44 & I-52

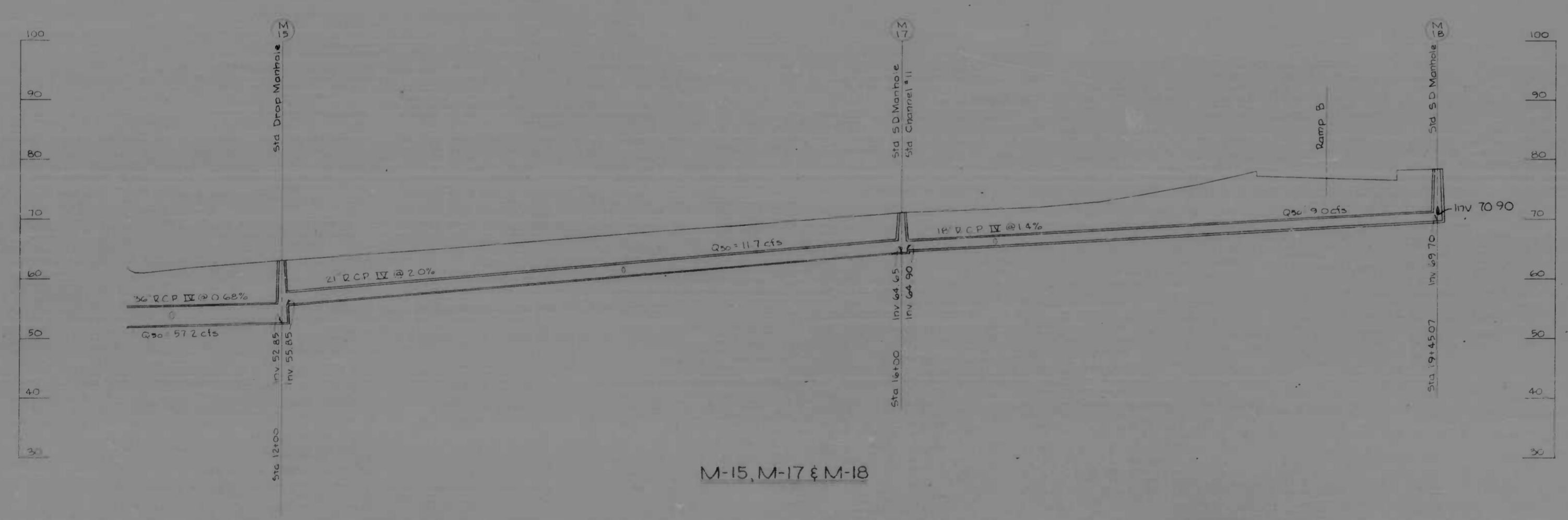

M-15, M-17 & M-18

REVISIONS	CONSULTANT	CITY OF BALTIMORE DEPARTMENT OF PUBLIC WORKS	STATE ROADS COMMISSION OF MARYLAND INTERSTATE DIVISION FOR BALTIMORE CITY
	KROERLE, BECKER, STONE & ASSOC., INC. AND MATZ, CHILDS & ASSOC., INC. CONSULTING ENGINEERS 341 N. CALVERT STREET BALTIMORE, MARYLAND 21202	INTERSTATE ROUTE 95 EASTERN AVENUE INTERCHANGE	DRAWN BY: CEP TRACED BY: ACB E.A.P. NO. I-95-4(32)36 S.R.C. NO. BC 246-29-815 BALTO CITY NO. 1959
		SCALE: 1" = 40' Horizontal, 1" = 10' Vertical	DES. BY: CEP CHK. BY: DES DATE: 4-27-70 SHEET NO. 77 OF 113

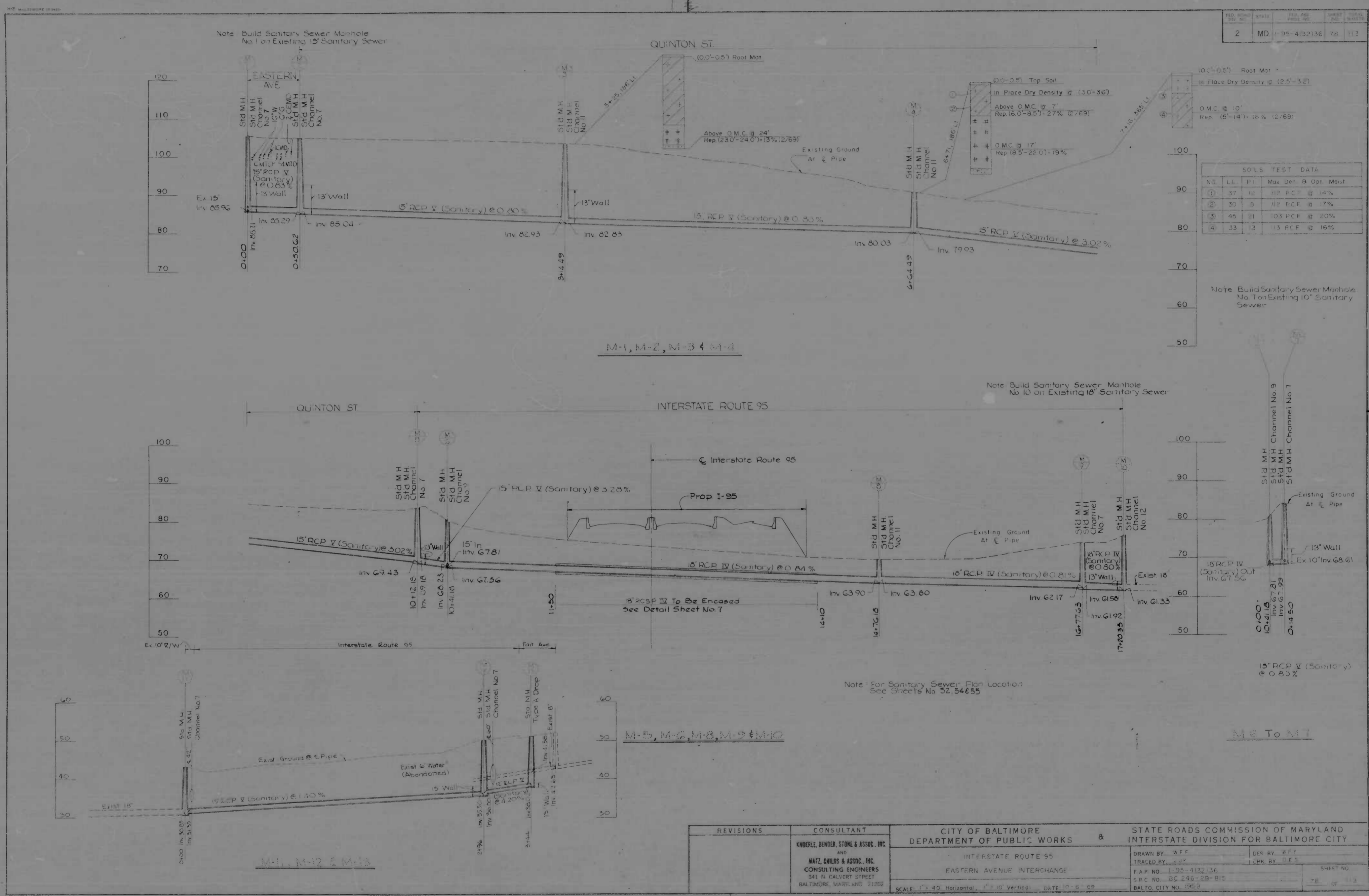

REV. NO.	DATE	BY	CHKD.
2	MD	95-4-32/36	78

SOILS TEST DATA				
NO.	LL	PI	Max Den. B	Opt. Moist
1	37	12	112 PCF @	14%
2	30	9	112 PCF @	17%
3	45	21	103 PCF @	20%
4	33	13	113 PCF @	16%

REVISIONS	CONSULTANT KINDLER, BENDER, STONE & ASSOC., INC. AND WATZ, CHILDS & ASSOC., INC. CONSULTING ENGINEERS 341 N. CALVERT STREET BALTIMORE, MARYLAND 21202	CITY OF BALTIMORE DEPARTMENT OF PUBLIC WORKS	STATE ROADS COMMISSION OF MARYLAND INTERSTATE DIVISION FOR BALTIMORE CITY
		INTERSTATE ROUTE 95 EASTERN AVENUE INTERCHANGE	DRAWN BY: RFF DES. BY: RFF TRACED BY: JJJ LCHK. BY: RFF F.A.P. NO. 95-432/36 S.R.C. NO. 82-246-29-85 BALTO. CITY NO. 1958
SCALE: 1" = 40' Horizontal, 1" = 10' Vertical, DATE: 10-8-89		SHEET NO. 78 OF 113	

FED. ROAD DIST. NO.	STATE	FED. AID PROJ. NO.	SHEET NO.	TOTAL SHEETS
2	MD.	I-95-4(3236)	79	113

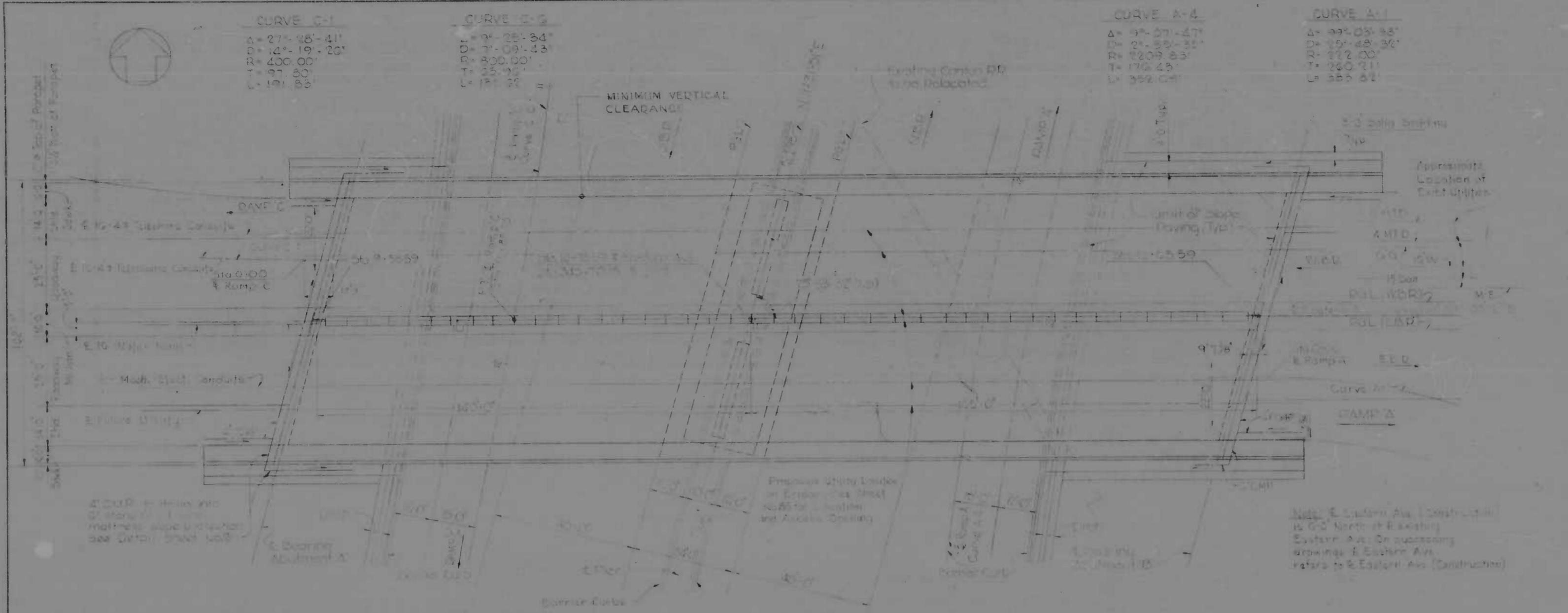

GENERAL NOTES:

SPECIFICATIONS: S.D.C. Specifications and Series B Specifications dated March 1958, and Special Provisions for materials and construction, A.A.S.H.O. Standard Specifications for Highway Bridges dated 1967 for design, including the 1960 Edition modifications for reinforced concrete design, Section 201.01. For prestressed concrete design, Section 201.02. Except that the concrete in Unit 21 shall also conform to 1700 c.s.

LOADING: HS-20-44 with provisions for a 2' future wearing surface.

CONCRETE: For all construction, except otherwise noted, the concrete shall be Class A-1 having a minimum compressive strength of 5000 psi at 28 days. For other concrete, see Special Provisions.

STEEL: All exposed members of concrete to be clad with mild steel. Clad for 1/8" unless otherwise noted.

REINFORCING: Reinforcing steel shall conform to ASTM A-615 and A-616.

PRESTRESSING: Prestressing steel tendons shall conform to ASTM A-421 and A-422, having a minimum ultimate strength of 170,000 psi. (See General Provisions).

STRUCTURAL: Structural steel shall be A-36, A-572, or A-588.

UTILITIES: See Series Provisions.

CONTROL: City Grid No. 11, E. 11th St. 14-416. Bridge deck in concrete with curb and sidewalks on Eastern Ave. & Eastern Ave. All structures are based on Baltimore City Datum.

CONTROL: The project is controlled by the Baltimore City Grid System.

NOTE:
FOR EASTERN AVENUE UNDERPASS LIGHTING SEE SHEET NO. 79A OF I-95

PLAN
Scale: 1" = 100'

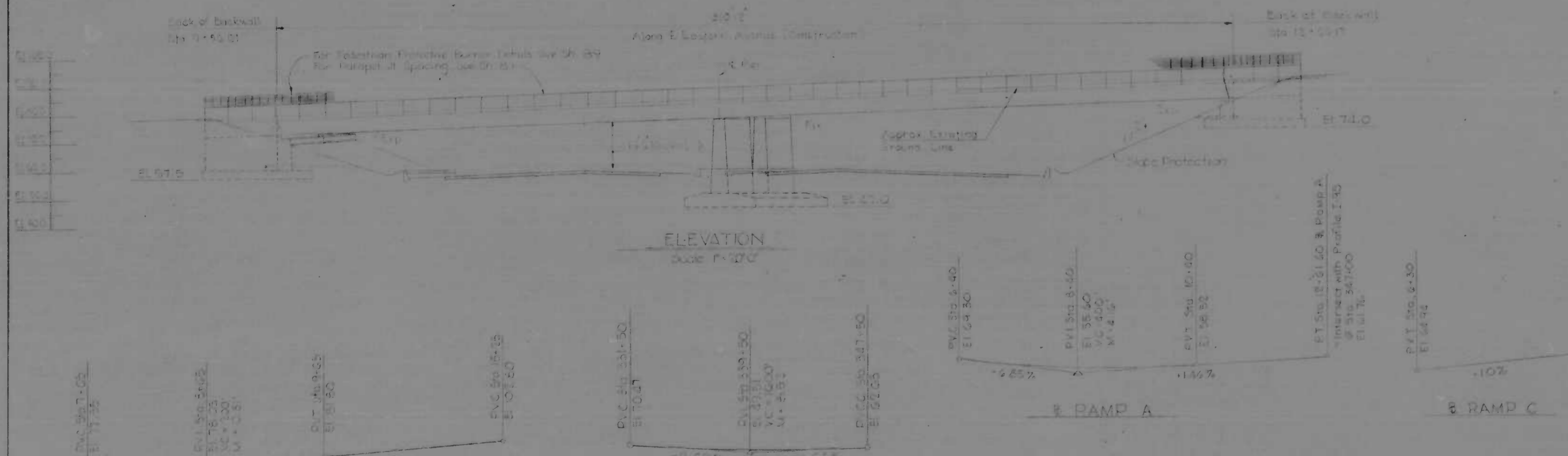

ELEVATION
Scale: 1" = 10'

REVISIONS [] Revised 7/7/71 D.A.E.	CONSULTANT KROFFLE, BENDER, STONE & ASSOC., INC. BALTO. OFFICE: 1000 N. CALVERT STREET BALTIMORE, MARYLAND 21202	CITY OF BALTIMORE DEPARTMENT OF PUBLIC WORKS & STATE ROADS COMMISSION OF MARYLAND INTERSTATE DIVISION FOR BALTIMORE CITY	
		EASTERN AVE. OVER I-95 GENERAL PLAN AND ELEVATION	
SCALE: AS NOTED		DATE: AUG 1969	
DRAWN BY: [] TRACED BY: []		DIS. BY: [] CHK. BY: []	
F.P. NO. I-95-4(3236) S.R.C. NO. B-24-25-85		SHEET NO. 79 OF 113	

41820

REV. NO.	DATE	BY	REASON
2	MD 1-95		

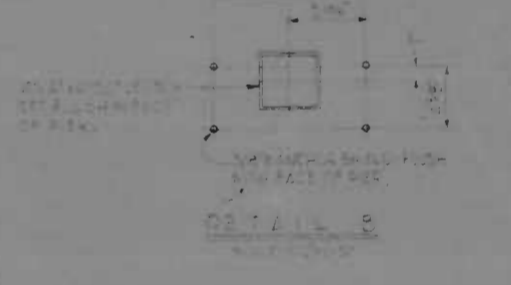
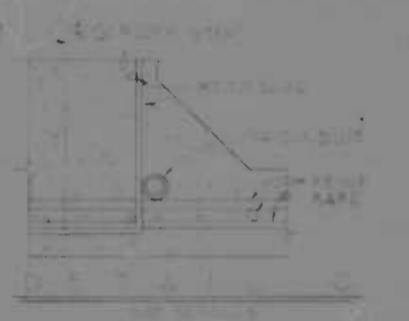
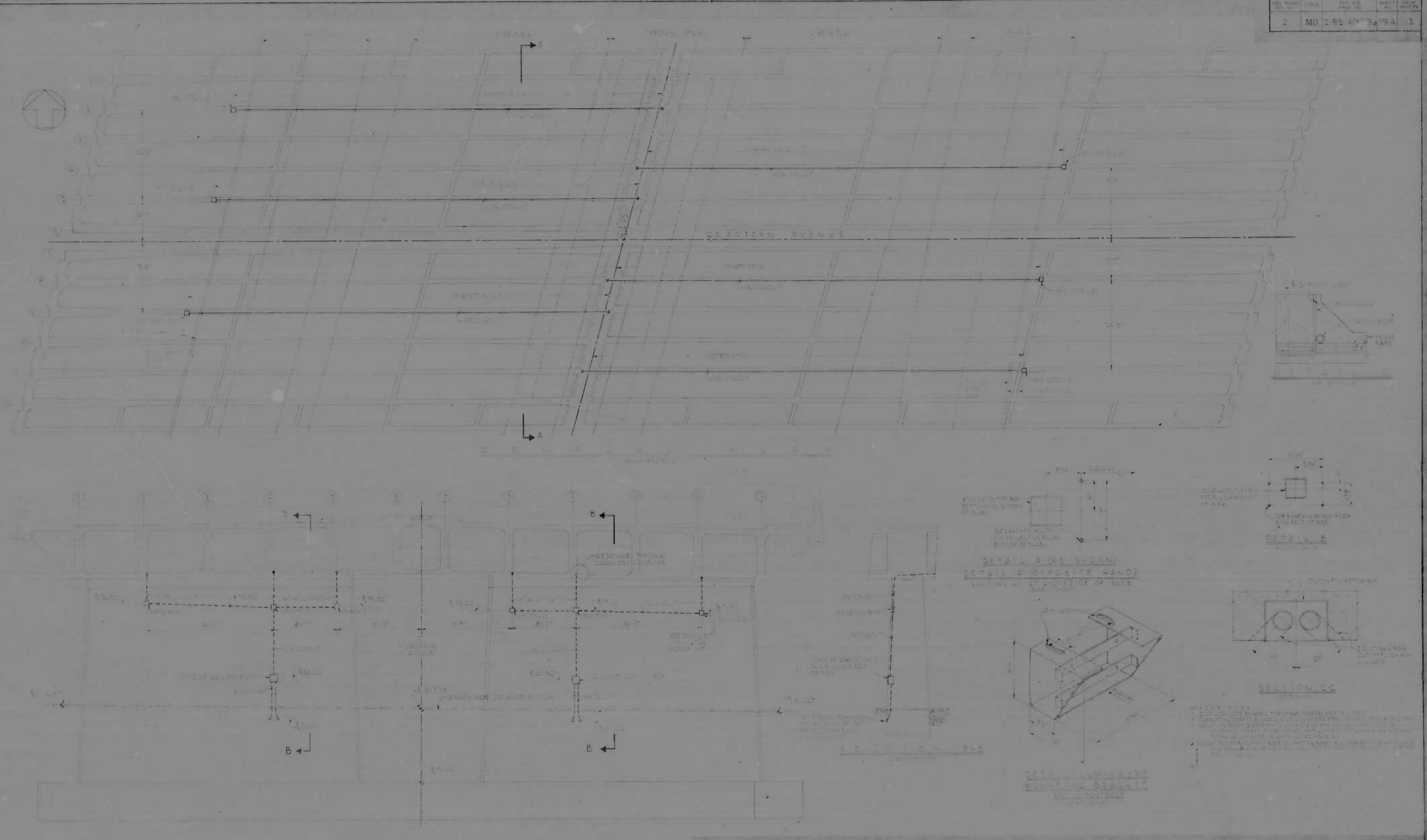

DETAIL A (AT CURB)
DETAIL B (OPPOSITE HAND)
LOOKING AT AN END VIEW OF SIDE

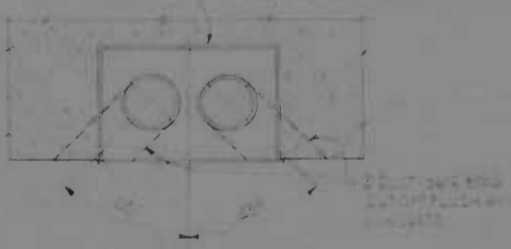
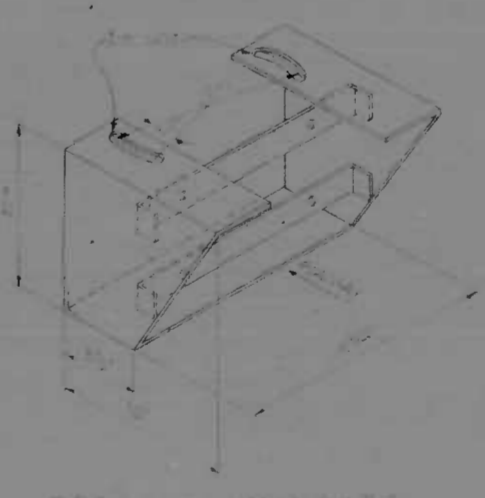

NOTES:
1. ALL DIMENSIONS ARE IN FEET AND INCHES.
2. ALL MATERIALS TO BE USED SHALL BE APPROVED BY THE ENGINEER.
3. ALL WORK SHALL BE DONE IN ACCORDANCE WITH THE STANDARD SPECIFICATIONS FOR PUBLIC WORKS OF THE CITY OF BALTIMORE.

SECTION A-A

REVISIONS ADJUSTED TO EXISTING CONTRACT 7-7-71	CONSULTANT JENNIFER, BENDER, STONE & ASSOC., INC. AND MATZ, CHILDS & ASSOC., INC. CONSULTING ENGINEERS 841 N. CALVERT STREET BALTIMORE, MARYLAND 21202	CITY OF BALTIMORE DEPARTMENT OF PUBLIC WORKS		STATE ROADS COMMISSION OF MARYLAND INTERSTATE DIVISION FOR BALTIMORE CITY	
		EASTERN AVE. OVER I-95 CONDUIT INSTALLATION		DRAWN BY TRACED BY P.A.P. NO. I-95 28737 S.R.C. NO. 20 10 70-95 BALTO. CITY NO. 059	DES. BY CHK. BY SHEET NO. 19 A OF 12
SCALE: AS NOTED		DATE			

PROJECT NO.	DATE	REV.	BY	CHK.	DATE
2	MD	05-01-2006	B	W	11/3

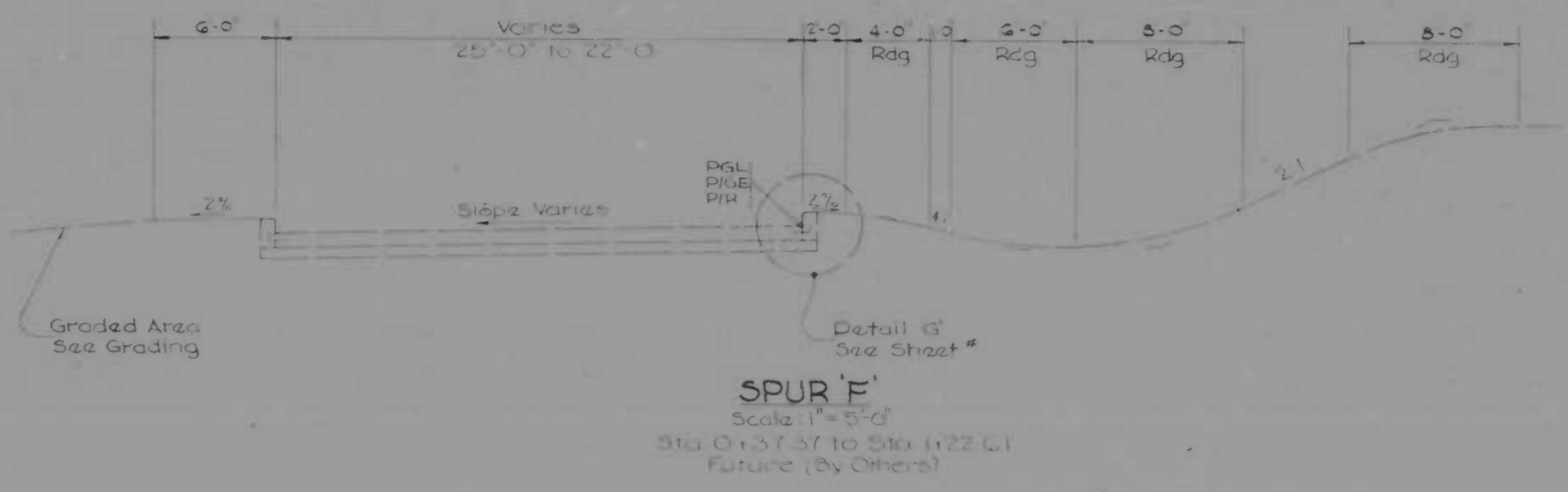

Note: All Side Slopes - 2:1 Topsoil, Seed & Mulch

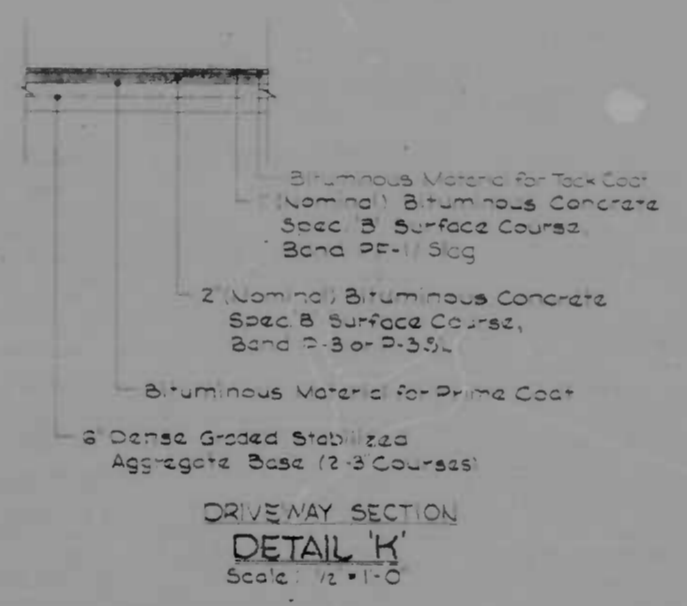
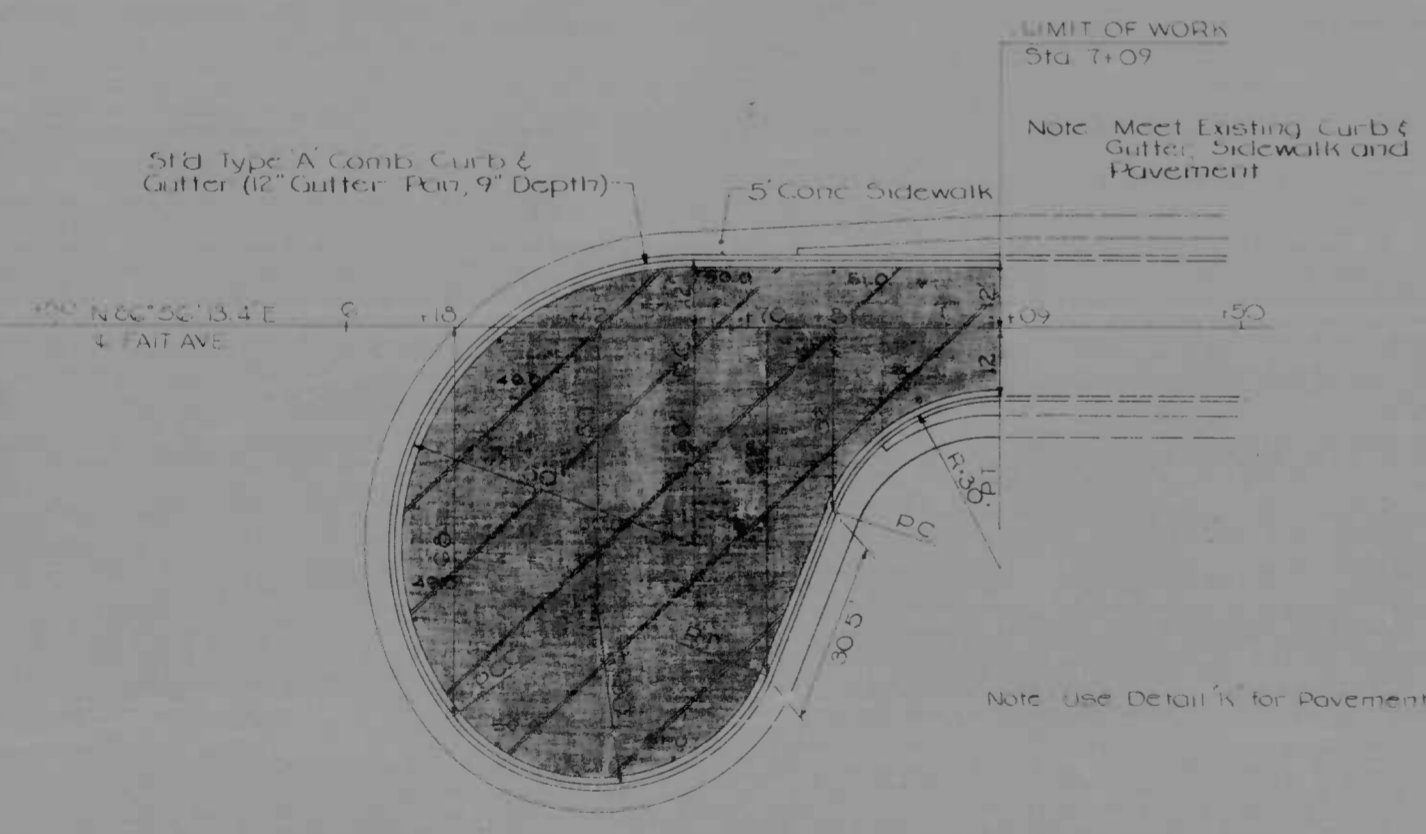

Note: To be Constructed if Directed by the Engineer for Control of Underground Springs & Sub-Grade Drainage Problems in Wet Cut Areas, Location & Type As Directed by the Engineer.

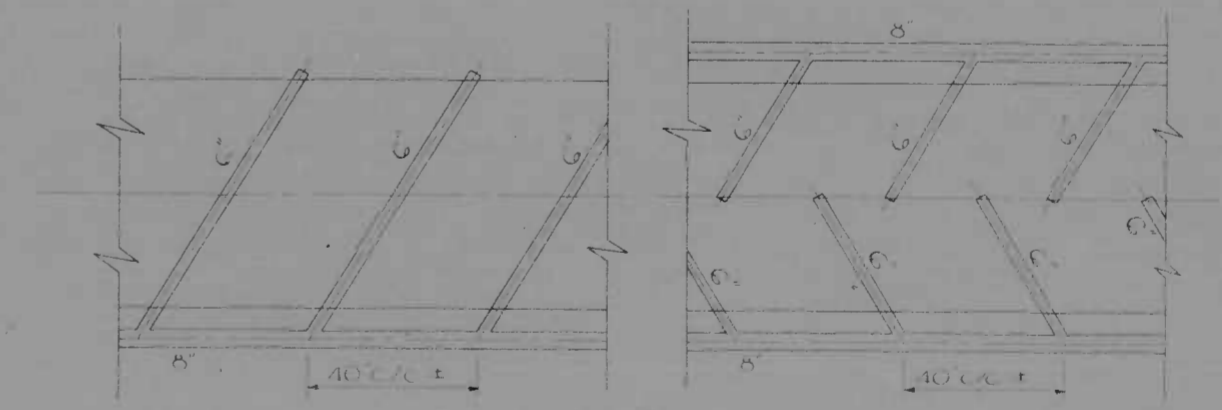

Materials: C - Perforated Round Underdrain Laterals
A - Perforated Round Underdrain
& Outlet Pipe as Required

REVISIONS	CONSULTANT	CITY OF BALTIMORE DEPARTMENT OF PUBLIC WORKS &	STATE ROADS COMMISSION OF MARYLAND INTERSTATE DIVISION FOR BALTIMORE CITY
	ANDRETTI, BERGER, SWINEY & ASSOC., INC. WATT, OYHOS & ASSOC., INC. CONSULTANTS & ENGINEERS 241 N. EAGLE STREET BALTIMORE, MD 21201	INTERSTATE ROUTE 95 EASTERN AVENUE INTERCHANGE	DRAWN BY: WEF TRACED BY: JUM DES. BY: CES CHK. BY: WEF
		SCALE: AS SHOWN	DATE: 4-20-70
			F.A.P. NO. 1-95-4132136 S.R.C. NO. 82-246-29-B1E BALTO. CITY NO. 1959
			SHEET NO. 8 OF 113

FED. ROAD DIST. NO.	STATE	FED. AID PROJ. NO.	SHEET NO.	TOTAL SHEETS
2	MD.	1-95-4(32)36	80	113

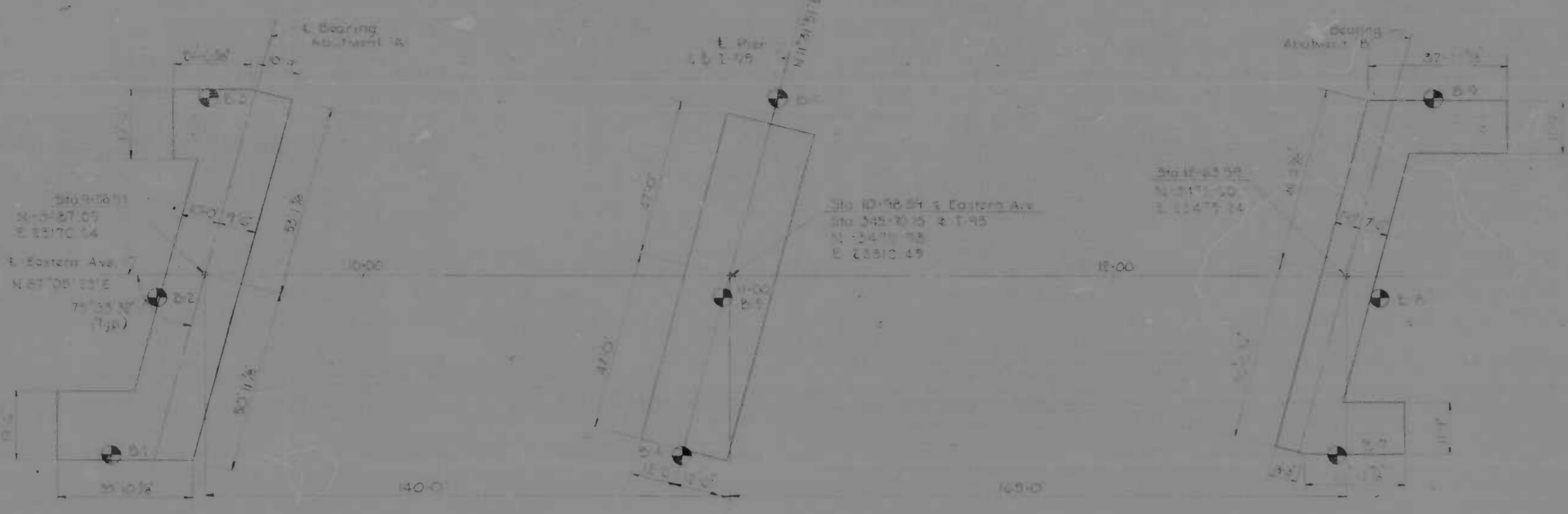

SUBSTRUCTURE LAYOUT
Scale: 1"=20'-0"

Note: ⊙ = Boring location. For boring logs see Sheet No. 91.



SECTION 80-A
Scale: 1/4"=1'-0"

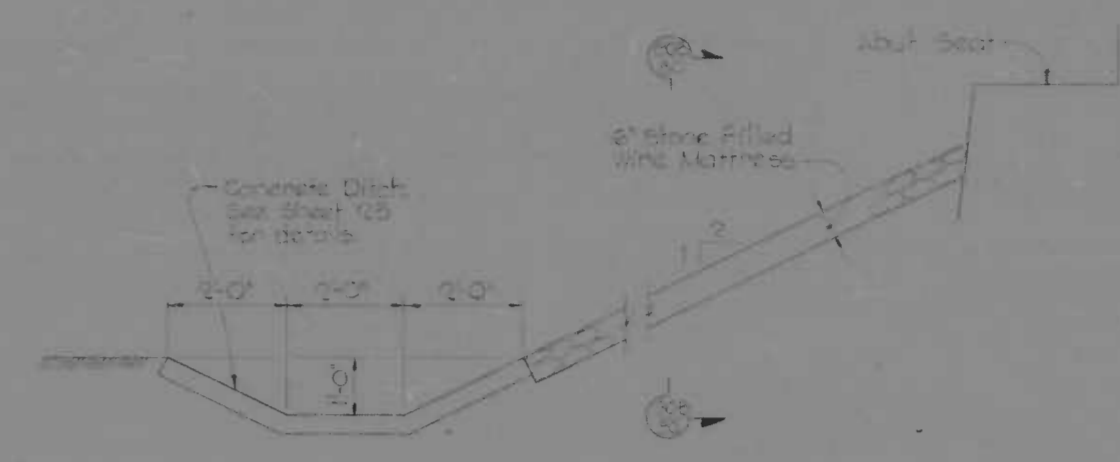

TYPICAL SECTION
Scale: 1/2"=1'-0"

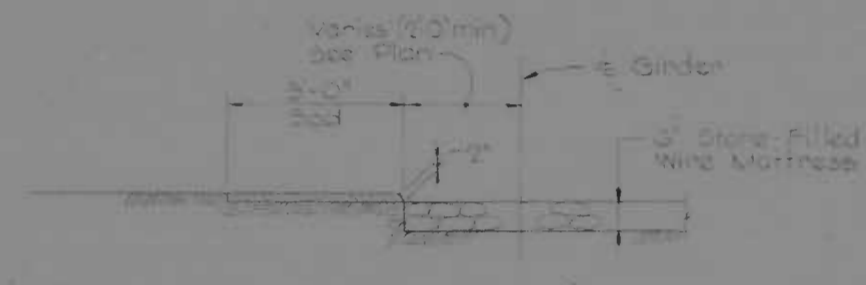

SECTION 80-B
Scale: 1/4"=1'-0"

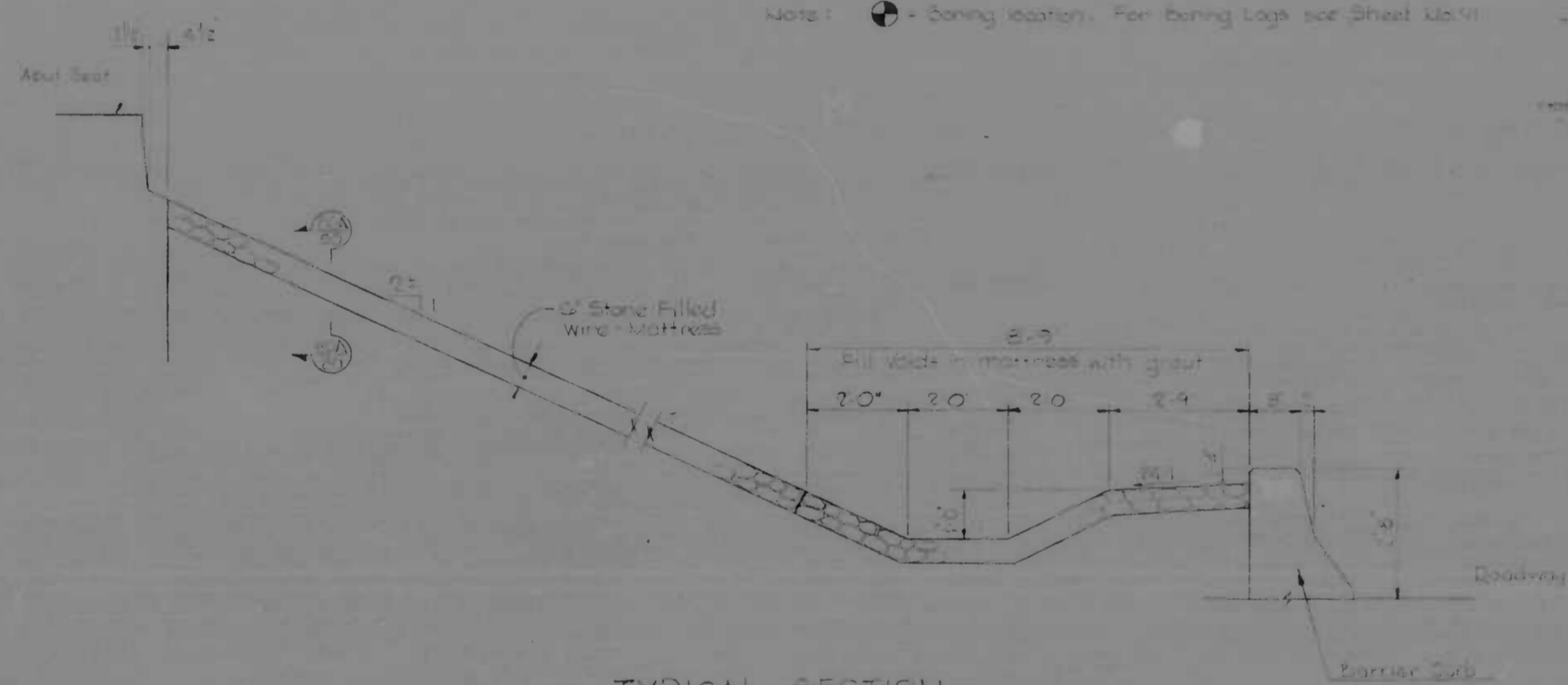

TYPICAL SECTION
Scale: 1/2"=1'-0"

SLOPE PROTECTION DETAILS - EASTERN AVE. BRIDGE

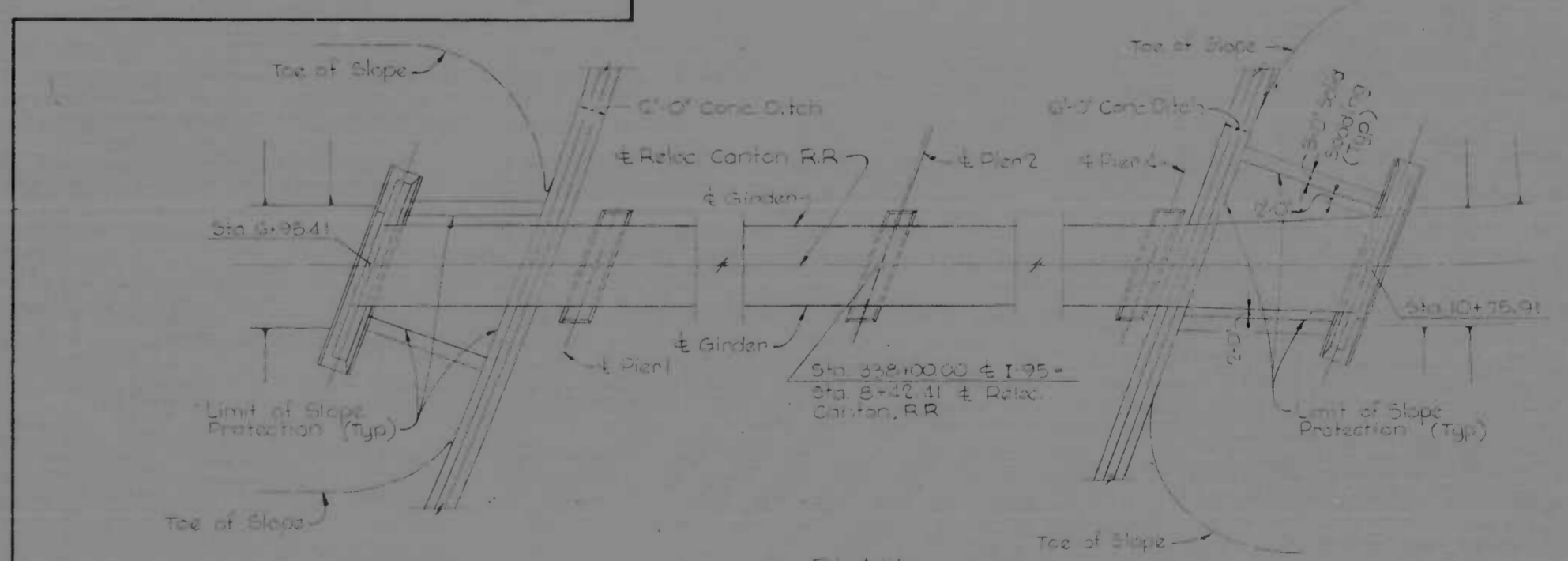

PLAN
Scale: 1"=20'-0"

SLOPE PROTECTION DETAILS - CANTON RR BRIDGE

QUANTITY BREAKDOWN		
Structure	Slope Protection	Ballast Sodding
Eastern Ave. Bridge	1225 SY	100 SY
Canton RR Bridge	325 SY	50 SY
Total	1550 SY	150 SY

REVISION:	CONSULTANT	CITY OF BALTIMORE DEPARTMENT OF PUBLIC WORKS	STATE ROADS COMMISSION OF MARYLAND INTERSTATE DIVISION FOR BALTIMORE CITY
	KNOERLE, BINDER, STONE & ASSOC., INC. 1400 MATZ, COLLIER & CO., INC. CONSULTING ENGINEERS 91 E. CALVERT STREET BALTIMORE, MARYLAND 21202	EASTERN AVE. OVER I-95 GEOMETRY LAYOUT	DRAWN BY: A. J. J. J. TRACED BY: A. J. J. J. F.A.P. NO. 1-95-4(32)36 S.P.C. NO. BC 244-26-86 BALTO. CITY NO. 1959
		DES. BY: A. J. J. J. CHK. BY: A. J. J. J.	SHEET NO. 80 of 113
		SCALE: AS NOTED	DATE: AUG. 15-69

FED. ROAD DIST. NO.	STATE	FED. AID PROJ. NO.	SHEET NO.	TOTAL SHEETS
2	MD	1-95-43236	81	115

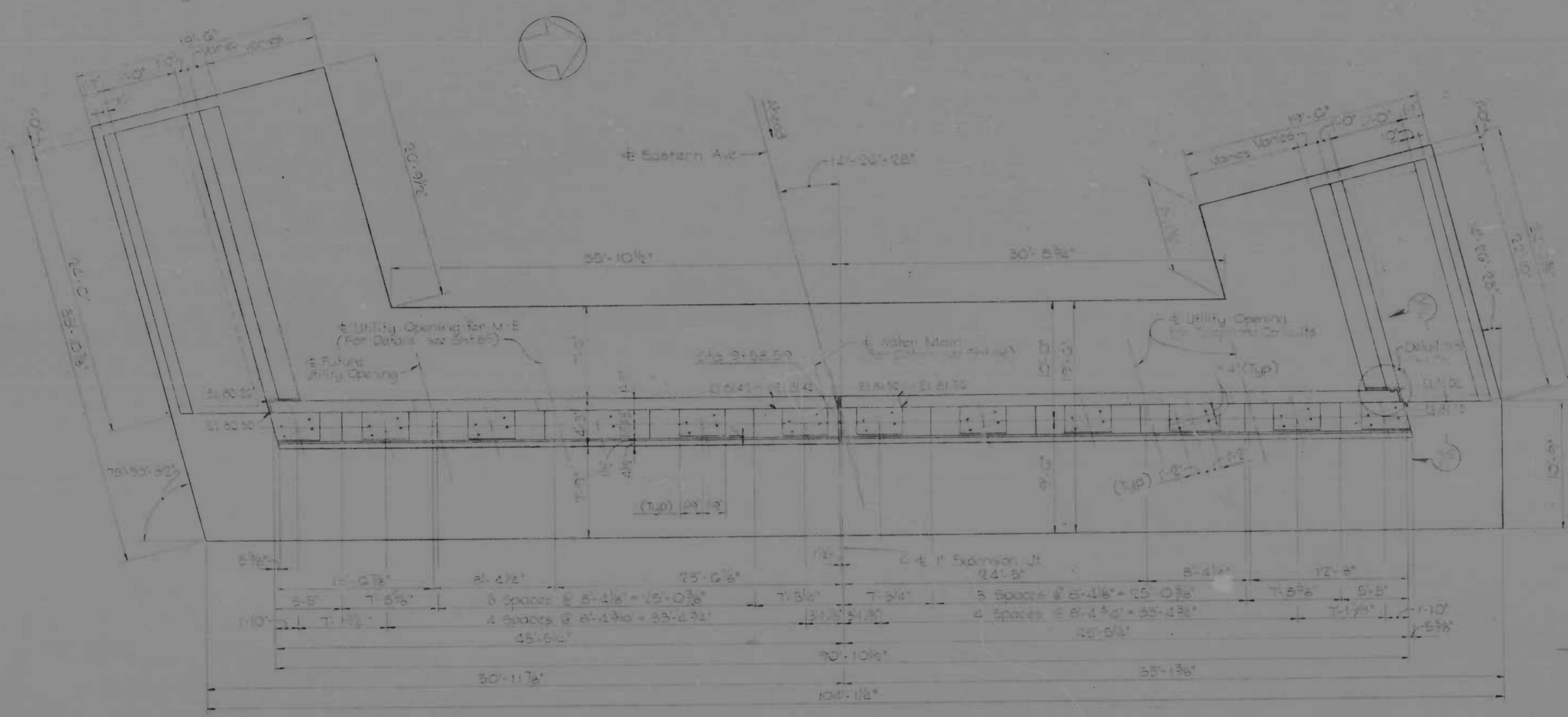

PLAN
Scale: 3/16" = 1'-0"

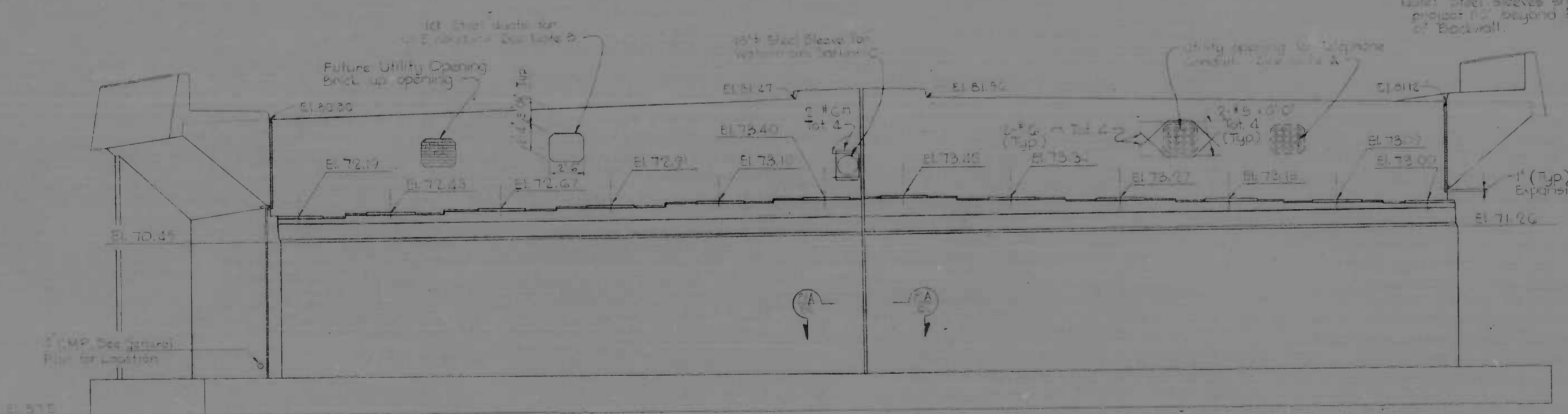

ELEVATION
Scale: 3/16" = 1'-0"

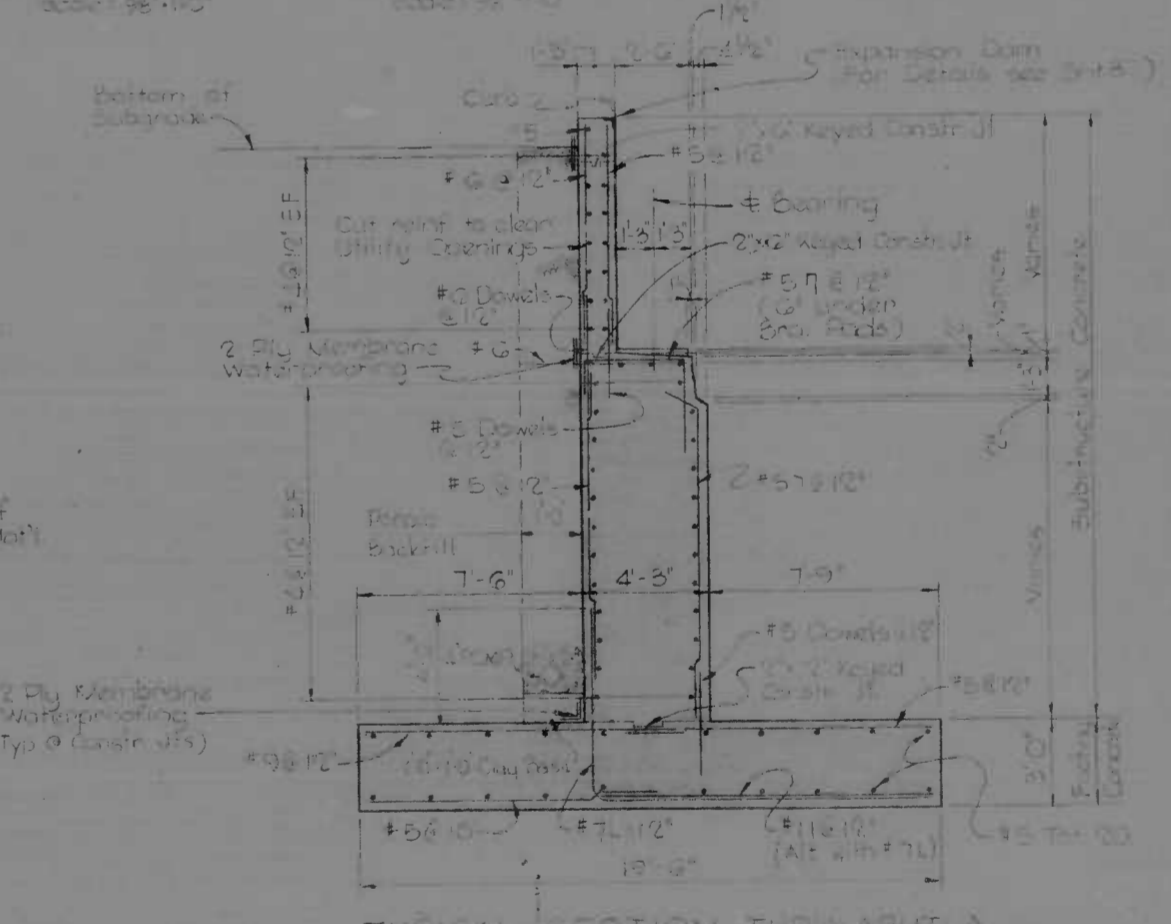
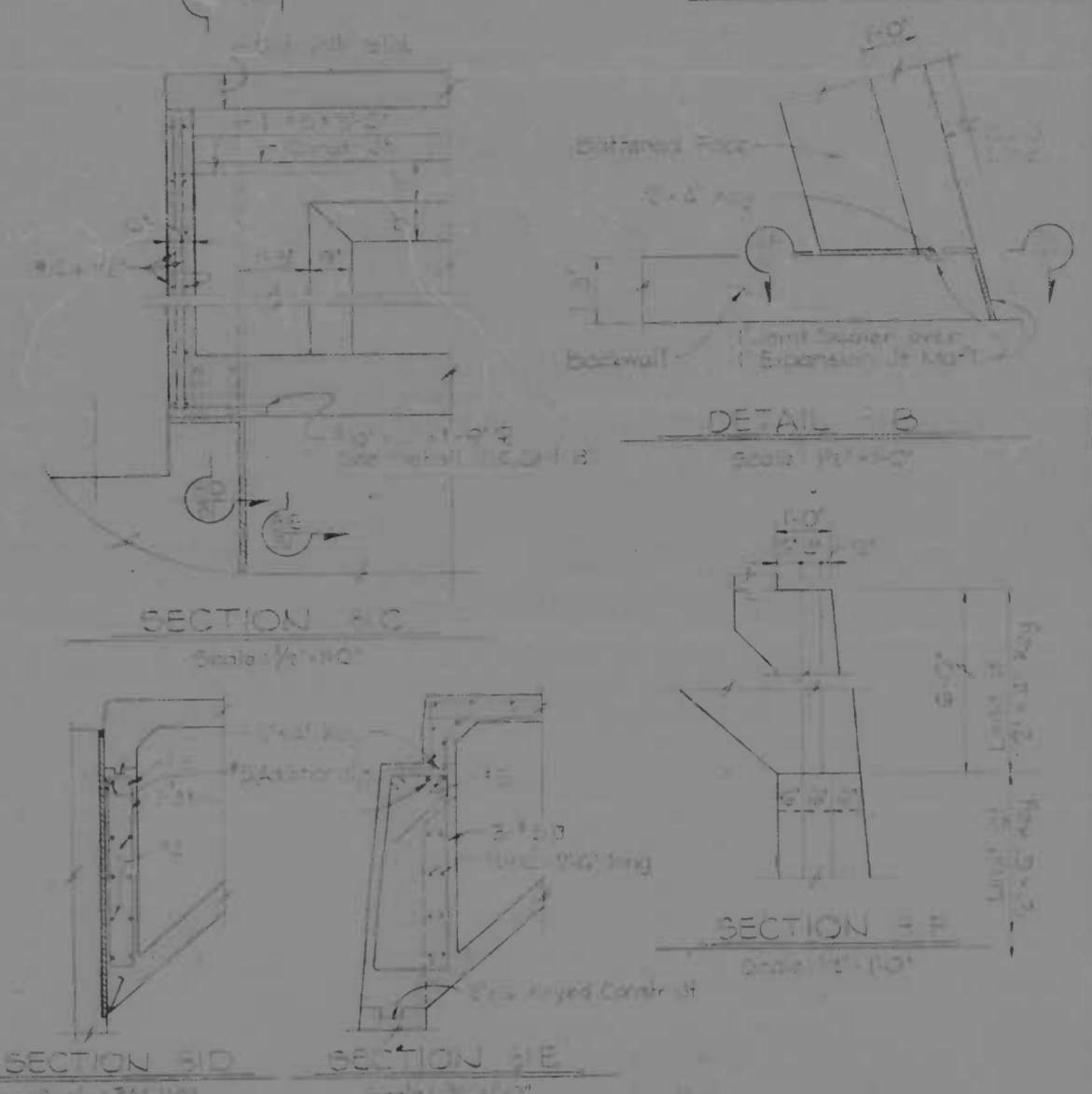

TYPICAL SECTION THRU ABUT A
Scale: 1/4" = 1'-0"

NOTES:

- Note A - Abutment back-wall shall not be poured until post-tensioning cables are in place and grouting is completed. See Note A 5H-B7.
- Note B - Reinforcing steel and post-tensioning cables shall be made up, setting, and bracing in the concrete before it is poured. The reinforcing steel shall be placed so as to conform with the drawings. See Note A 5H-B7.
- Note C - Utility opening for 4" gas ducts. Steel ducts shall be 4" x 4" x 1/4" thick. See Note A 5H-B7.

Note B - 8" x 8" steel ducts to match B-2's cables cannot duct. Use 8" x 8" steel ducts to match 1" x 3/4" cables. Cement ducts installation and materials this contract. See Note A 5H-B7.

Note C - 18" x 18" steel sleeve for 12" water main. Installation and materials this contract. See Note A 5H-B7.

NOTE: ADJUSTMENT A

Allowable soil bearing pressure = 1.5 TSF
Design footing bearing pressure = 1.5 TSF

REVISIONS	CONSULTANT	CITY OF BALTIMORE DEPARTMENT OF PUBLIC WORKS	STATE ROADS COMMISSION OF MARYLAND INTERSTATE DIVISION FOR BALTIMORE CITY
	KIMBELL, BENDER, STONE & ASSOC., INC. WATZ, ERNDS & ASSOC., INC. CONSULTING ENGINEERS 241 F. CALVERT STREET BALTIMORE, MARYLAND 21202	EASTERN AVE. OVER I-95 ABUTMENT A	DRAWN BY: [] TRACED BY: [] F.A.P. NO. 1-95-43236 S.R.C. NO. BC 2-15-26-R15 BALTO. CITY NO. 1959
SCALE AS NOTED	DATE AUG 1969	DES. BY: [] CHK. BY: []	SHEET NO. 113

PRO. ROAD DIST. NO.	STATE	FED. AID PROJ. NO.	SHEET NO.	TOTAL SHEETS
2	MD	1-98-5216	82	113

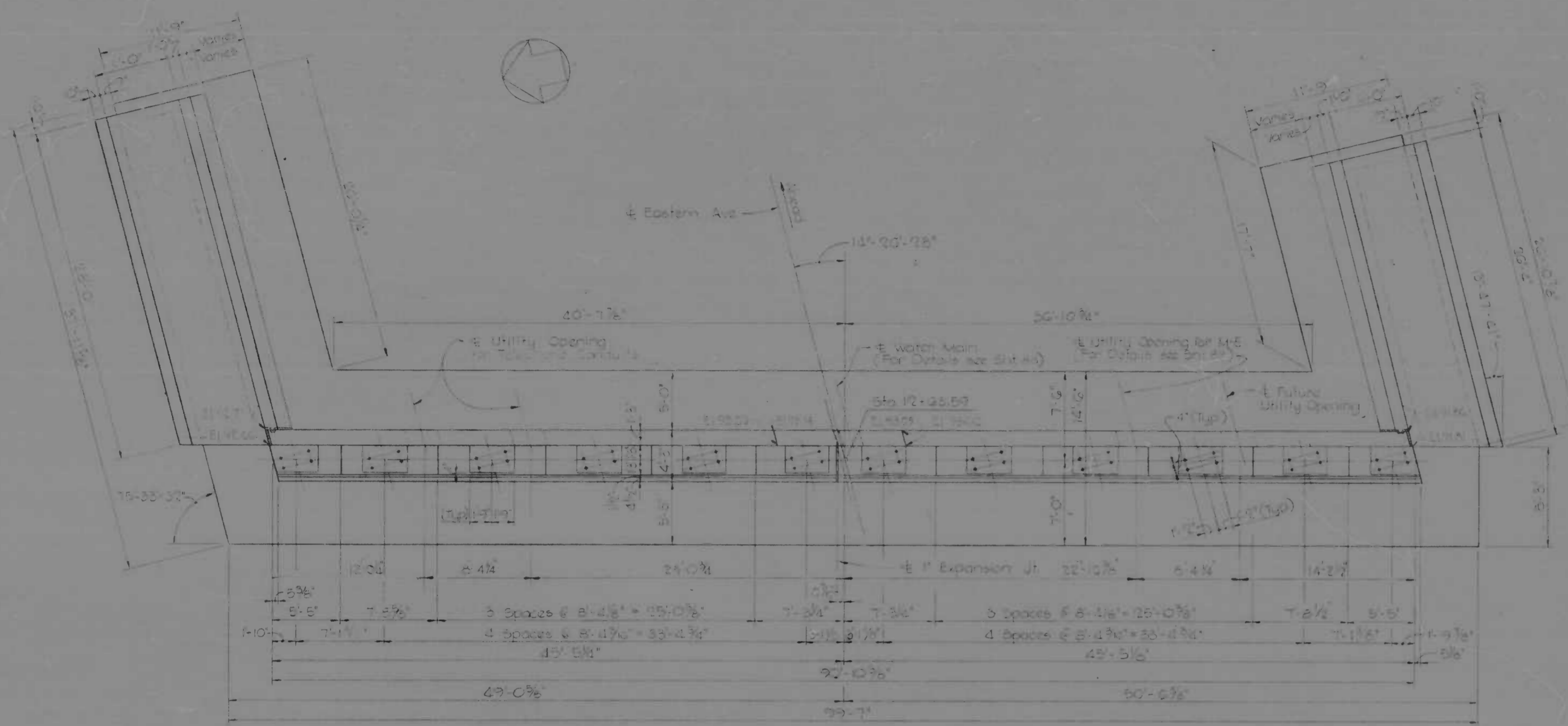

PLAN
Scale: 1/8" = 1'-0"

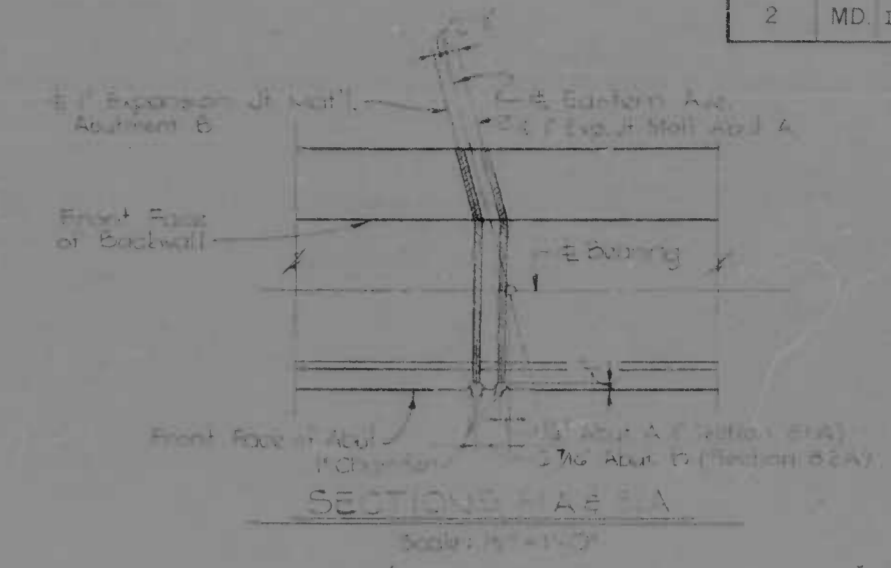

SECTION A-A & B-B
Scale: 1/4" = 1'-0"

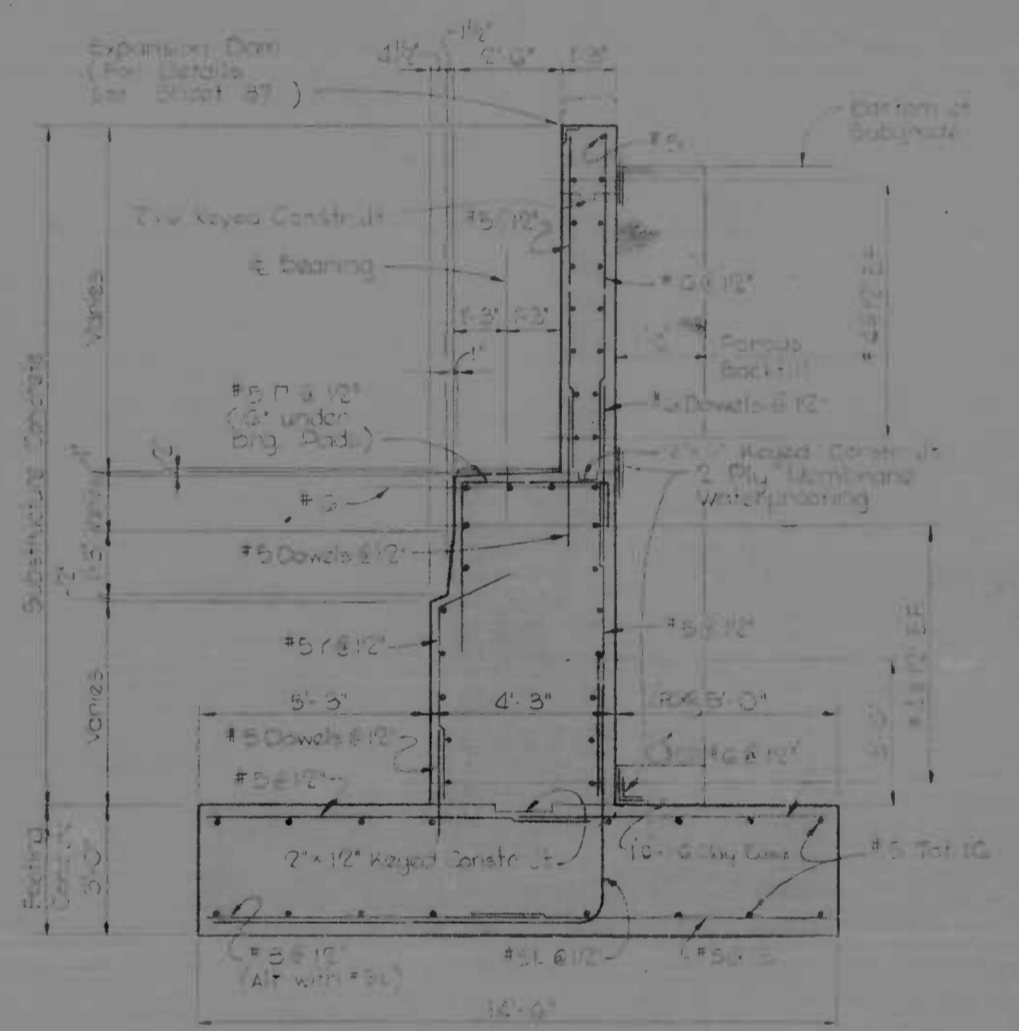

TYPICAL SECTION THRU ABUT B
Scale: 3/8" = 1'-0"

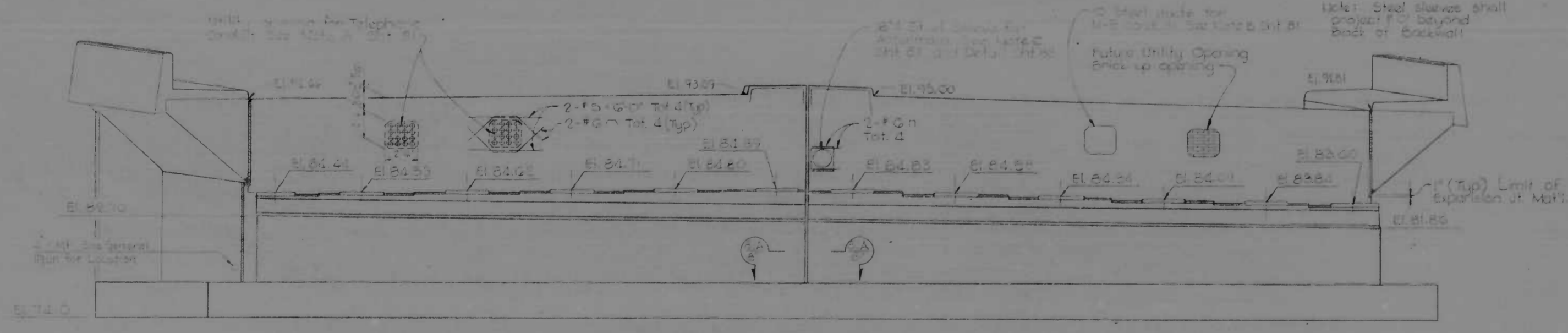

ELEVATION
Scale: 3/8" = 1'-0"

NOTE: ABUTMENT "B"
Allowable soil bearing pressure = 2 TCF
Design footing bearing pressure = 2 TCF

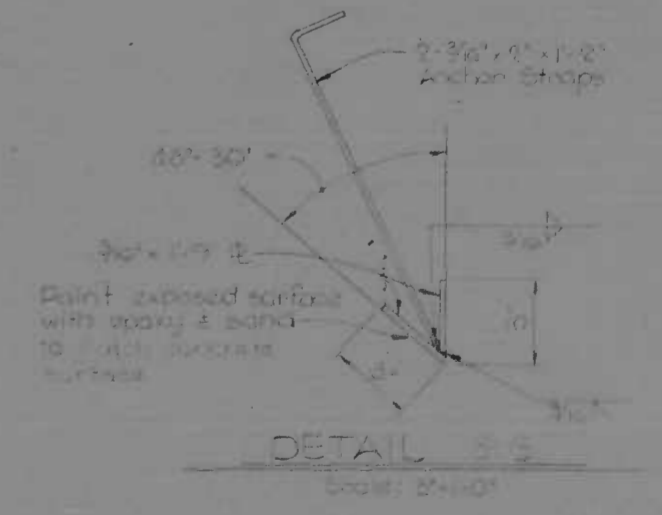

DETAIL S-S
Scale: 2" = 1'-0"

REVISIONS	CONSULTANT	CITY OF BALTIMORE DEPARTMENT OF PUBLIC WORKS	STATE ROADS COMMISSION OF MARYLAND INTERSTATE DIVISION FOR BALTIMORE CITY
	KAMRER, BUNZ, STONE & ASSOC., INC. AND MATZ, CURCO & ASSOC., INC. CONSULTING ENGINEERS 411 S. CALVERT STREET BALTIMORE, MARYLAND 21202	EASTERN AVE. OVER I-95 ABUTMENT B	DRAWN BY: PLS TRACED BY: KCO DES. BY: PLS CHK. BY: PLS F.P. NO. 180-413206 S.R.C. NO. BC 246 26 815 BALTO. CITY NO. 1953
		SCALE: AS NOTED	DATE: AUG 1963
			SHEET NO. 82 OF 113

FED. ROAD DIST. NO.	STATE	FED. AID PROJ. NO.	SHEET NO.	TOTAL SHEETS
2	MD	I-95-4(32)36	83	113

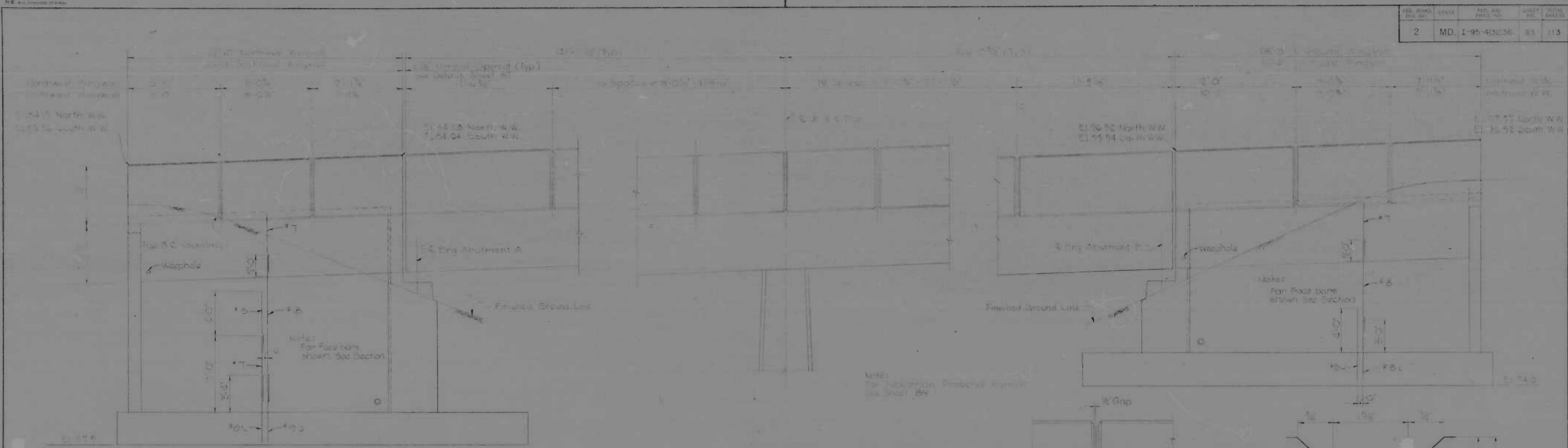

PARAPET JOINT SPACING
Scale 1/4"=1'-0"
SOUTH ELEVATION SHOWN



INTERIOR ELEVATION
DEFLECTION JOINT
Scale 1/4"=1'-0"

FULL SIZE DETAIL OF JOINT

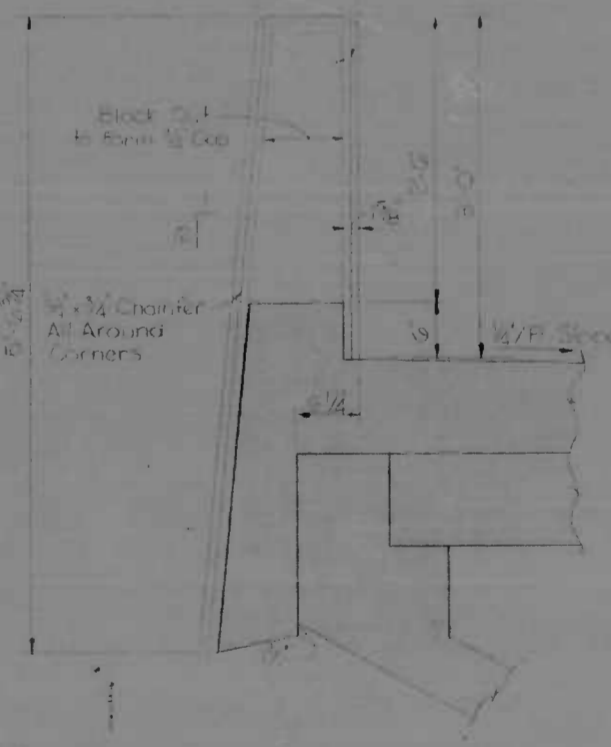

SECTION THRU CONCRETE PARAPET JOINT
Scale 1/4"=1'-0"

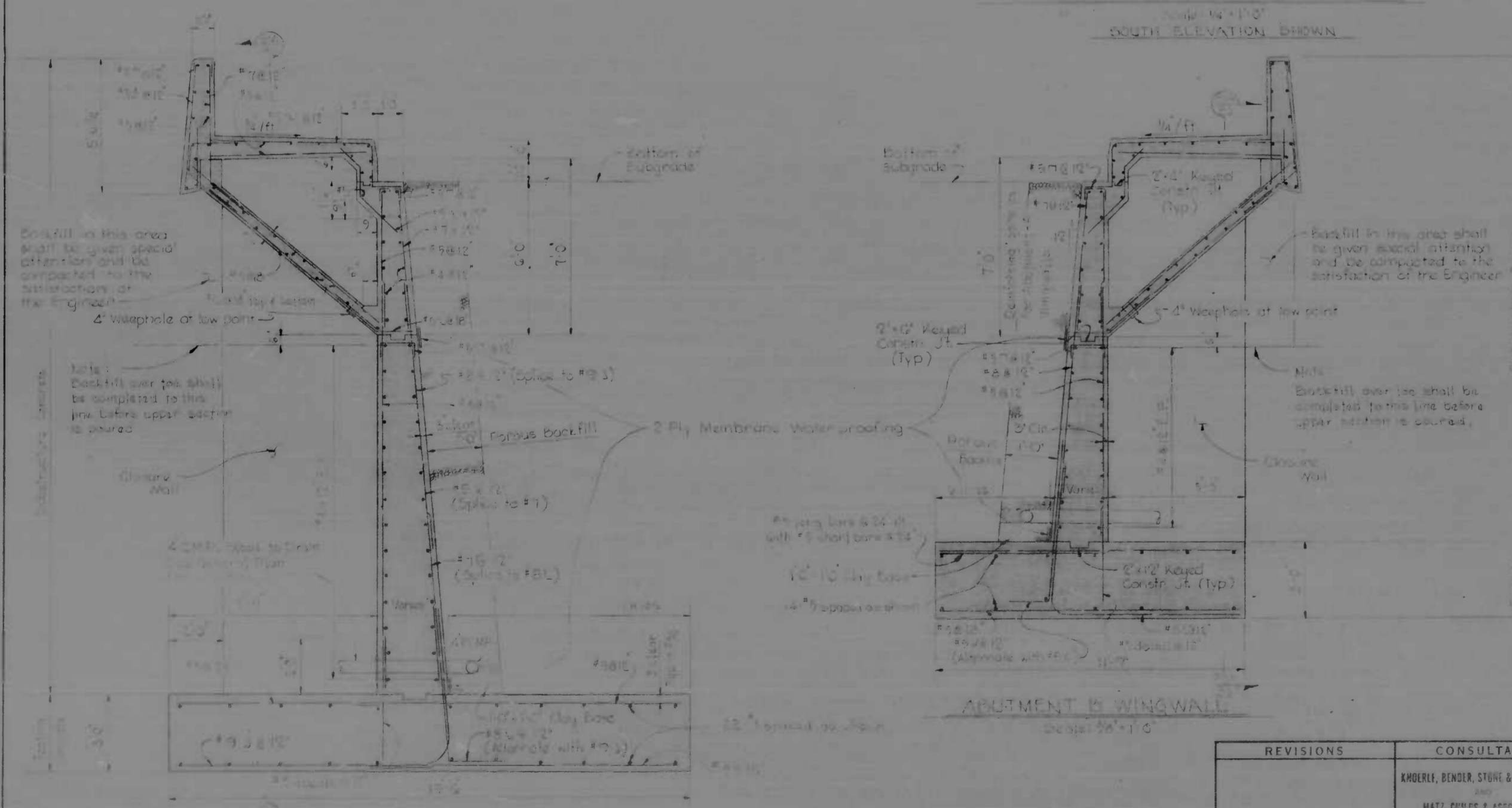

ABUTMENT B WINGWALL
Scale 3/8"=1'-0"

ABUTMENT A WINGWALL
Scale 3/8"=1'-0"

REVISIONS	CONSULTANT	CITY OF BALTIMORE DEPARTMENT OF PUBLIC WORKS & STATE ROADS COMMISSION OF MARYLAND INTERSTATE DIVISION FOR BALTIMORE CITY	
	KHOUREY, BENDER, STONE & ASSOC., INC. 300 MATZ, CHOLE & ASSOC., INC. CONSULTING ENGINEERS 311 N. CALVERT STREET BALTIMORE, MARYLAND 21202	EASTERN AVE. OVER I-95 ABUTMENT DETAILS	
		SCALE: AS NOTED	DATE: AUG 1969
		DRAWN BY: V.T.H. TRACED BY: V.T.H.	DES. BY: J.P.S. CHK. BY: J.P.S.
		F.A.P. NO. I-95-4(32)36 S.R.C. NO. BC 246-26-015 BALTO. CITY NO. 1952	SHEET NO. 83 OF 113

FED. ROAD DIST. NO.	STATE	FED. AID PROJ. NO.	SHEET NO.	TOTAL SHEETS
2	MD.	1-95-432-36	84	113

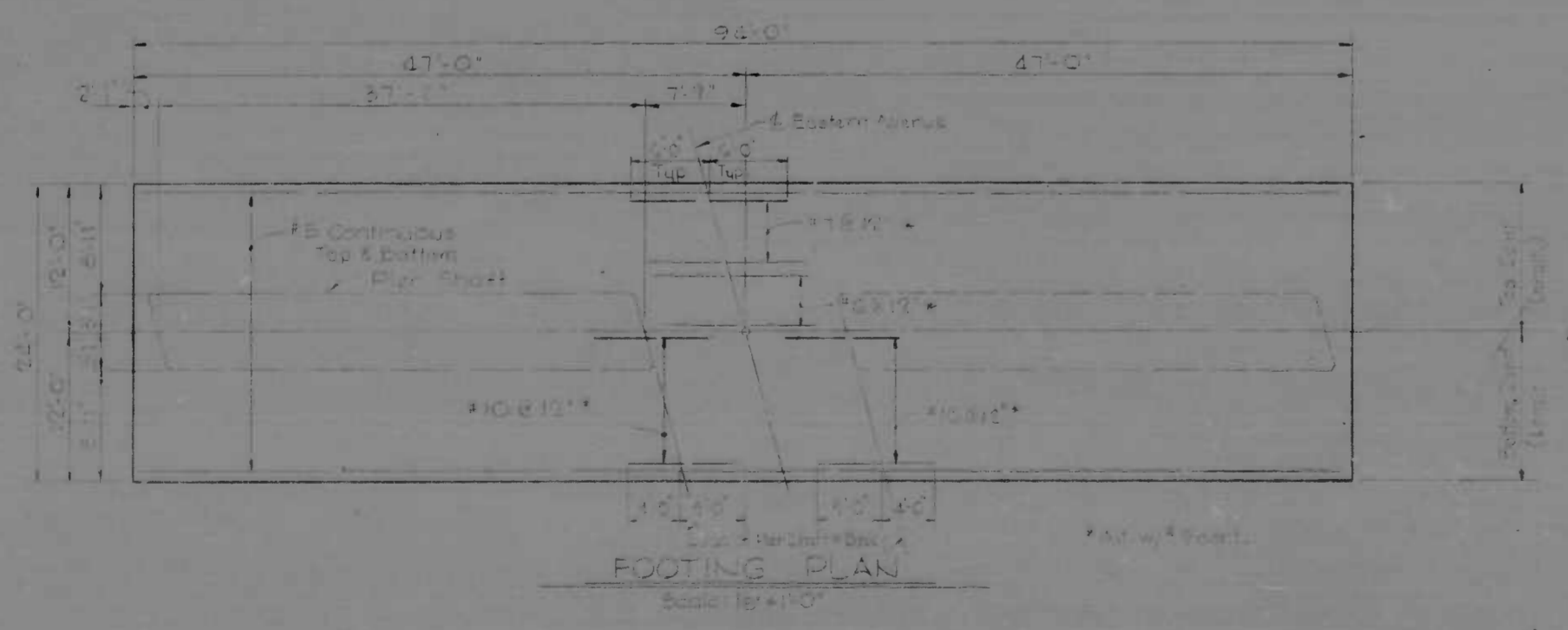
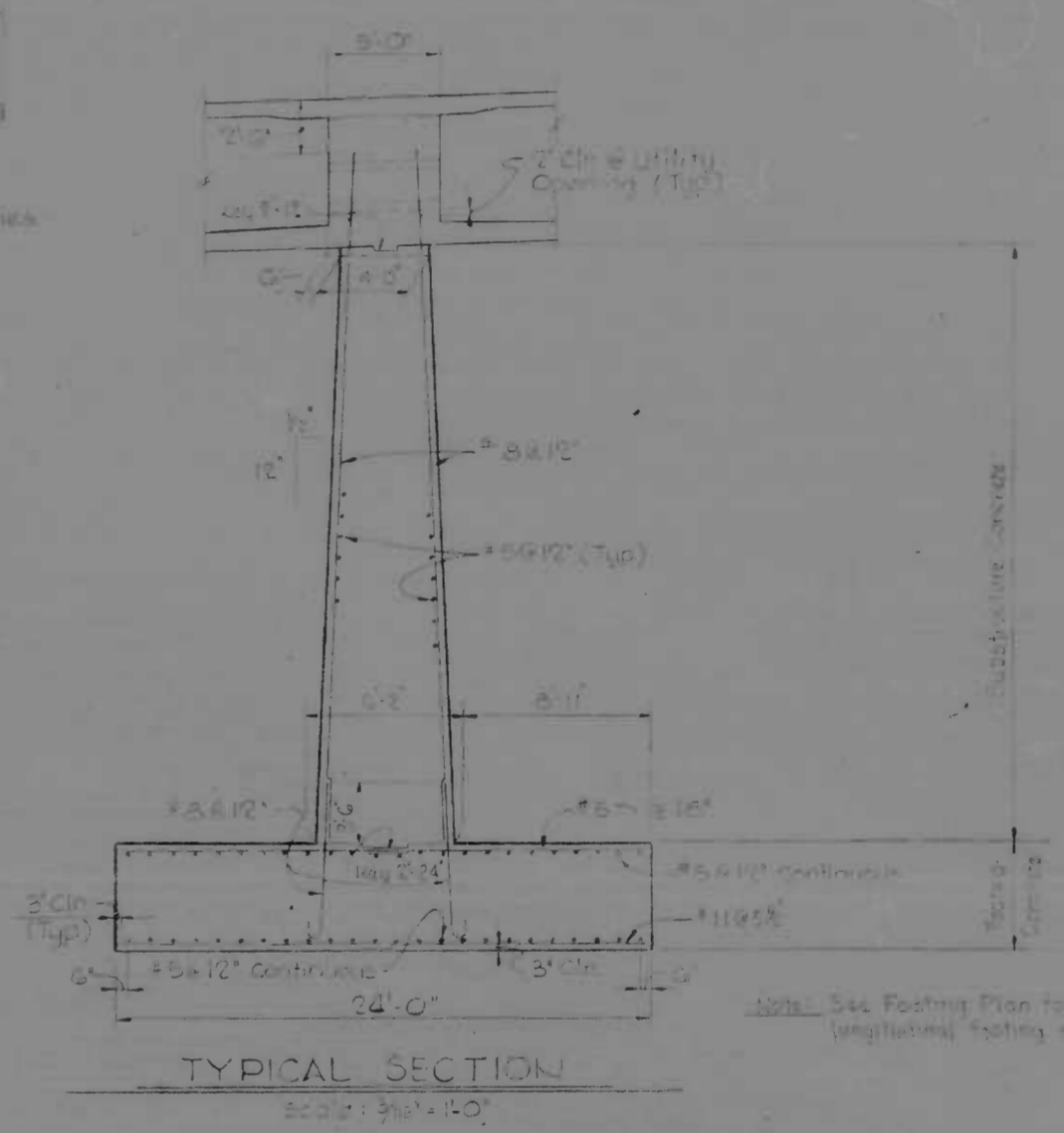
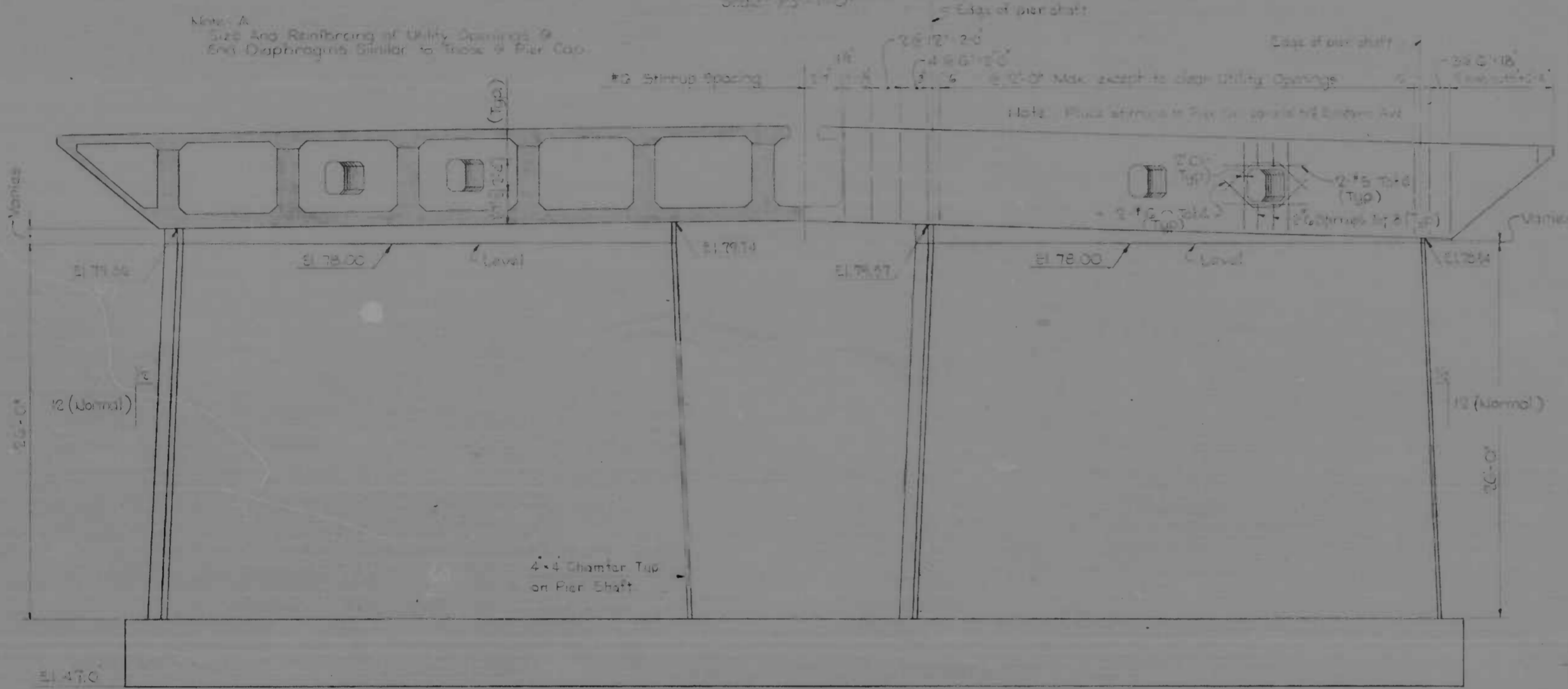
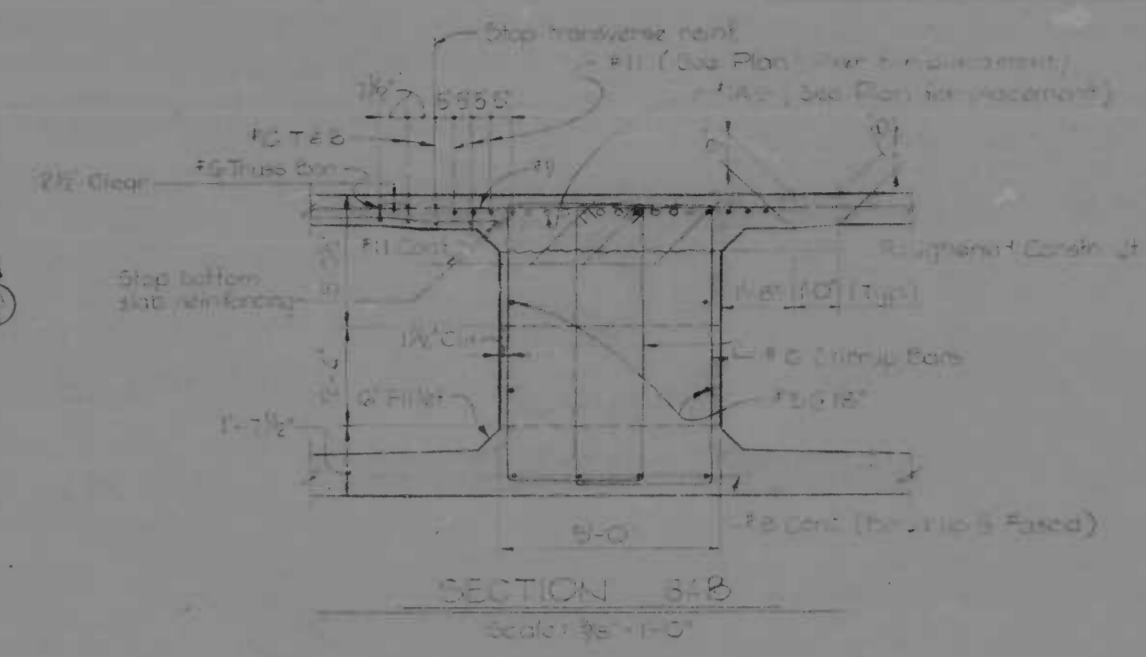
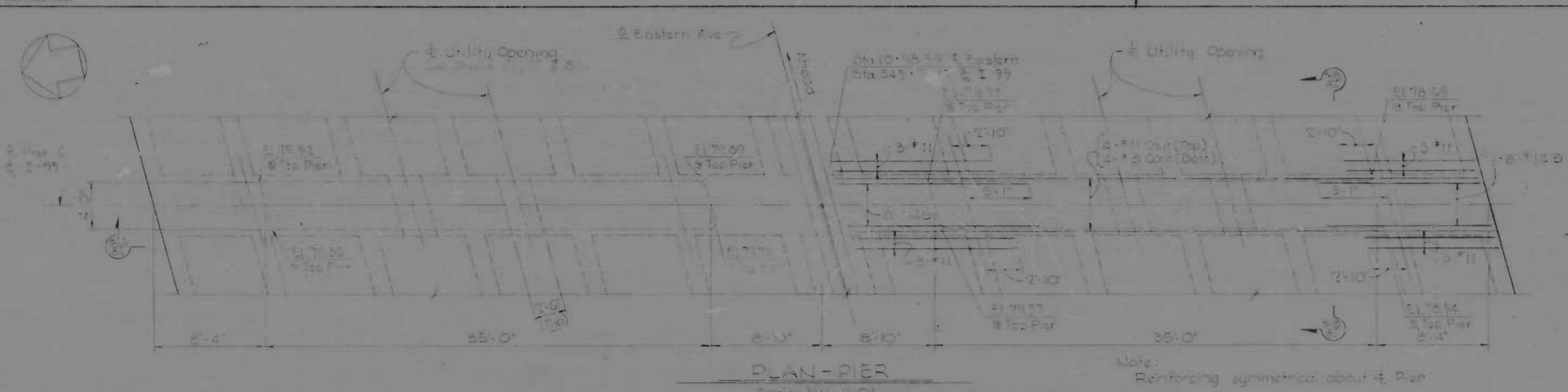

NOTES - PIER
 1. Allowable soil bearing pressure 4 TSP
 2. Design footing bearing pressure 4 TSP
 3. No access shall be visible on Pier shafts
 4. Form joints shall be taped.

REVISIONS	CONSULTANT	CITY OF BALTIMORE DEPARTMENT OF PUBLIC WORKS & EASTERN AVE. OVER I-95 PIER	STATE ROADS COMMISSION OF MARYLAND INTERSTATE DIVISION FOR BALTIMORE CITY
	KNORRLE, BENNETT, STONE & ASSOC., INC. HALL, CROSSLAND & ASSOC., INC. CONSULTING ENGINEERS 343 N. CALVERT STREET BALTIMORE, MARYLAND 21202	DRAWN BY TRACED BY F.A.P. NO. I-95-432-36 S.R.C. NO. BC-245-28-810 BALTO. CITY NO. 1959	DES. BY CHK. BY SHEET NO. 84 of 113
		SCALE: AS NOTED	DATE: AUG 1969

1211169 4/12/70

PROJECT NO.	DATE	DESIGN NO.	SHEET NO.	TOTAL SHEETS
2	MD	195-4132/56	548	117

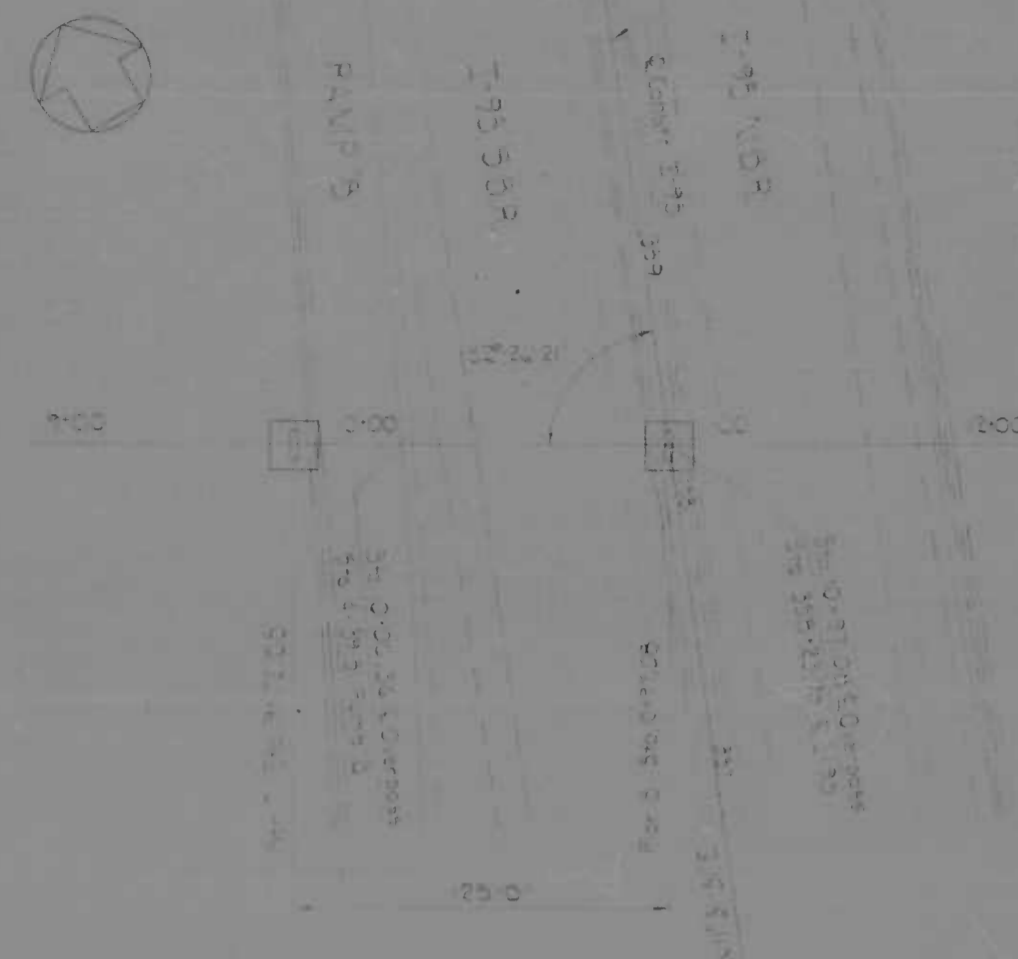

LOCATION PLAN
Scale: 1/4" = 1'-0"

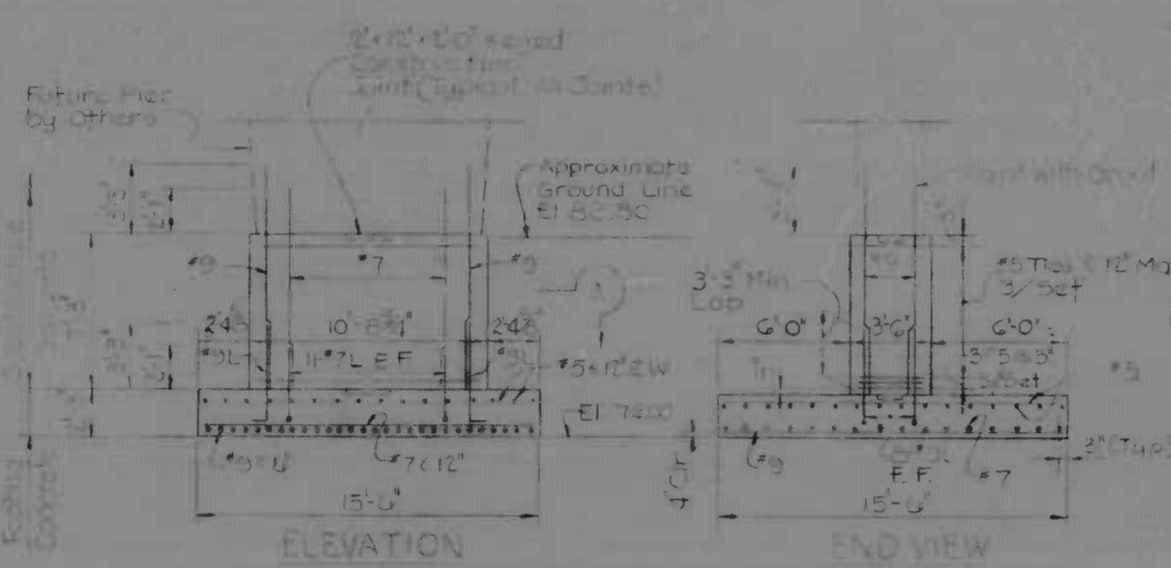

ELEVATION
Scale: 1/4" = 1'-0"

END VIEW
Scale: 1/4" = 1'-0"

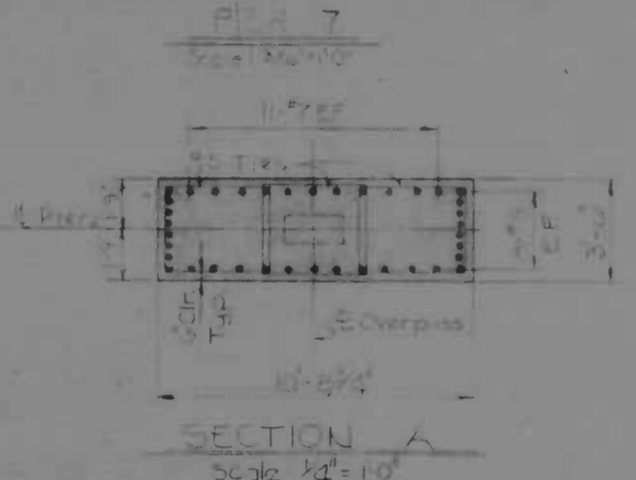

SECTION A
Scale: 1/4" = 1'-0"

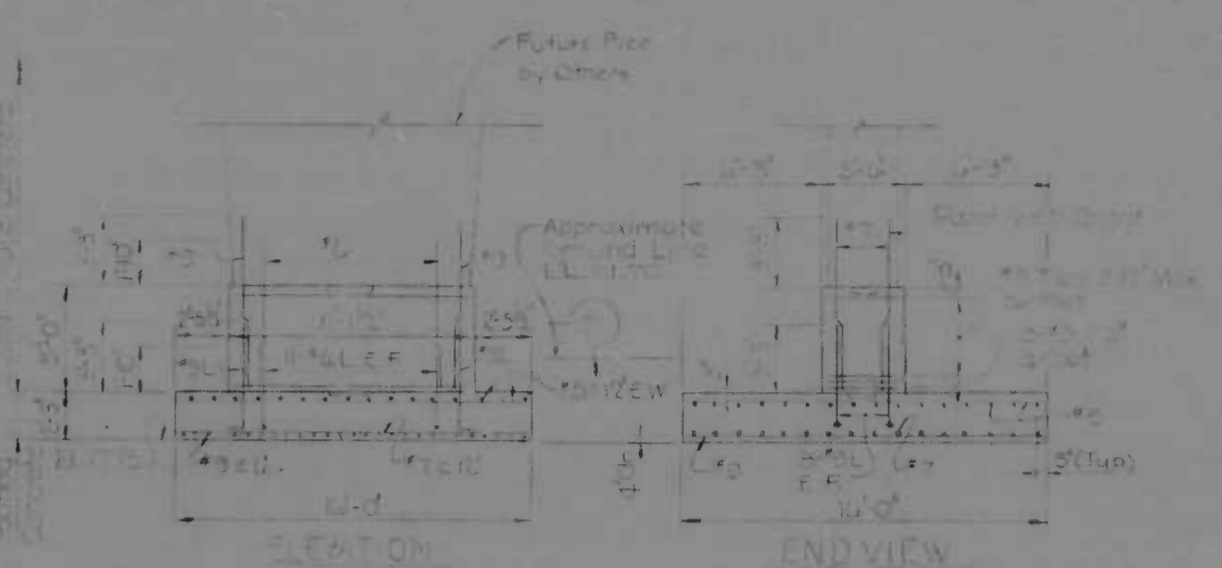

ELEVATION
Scale: 1/4" = 1'-0"

END VIEW
Scale: 1/4" = 1'-0"

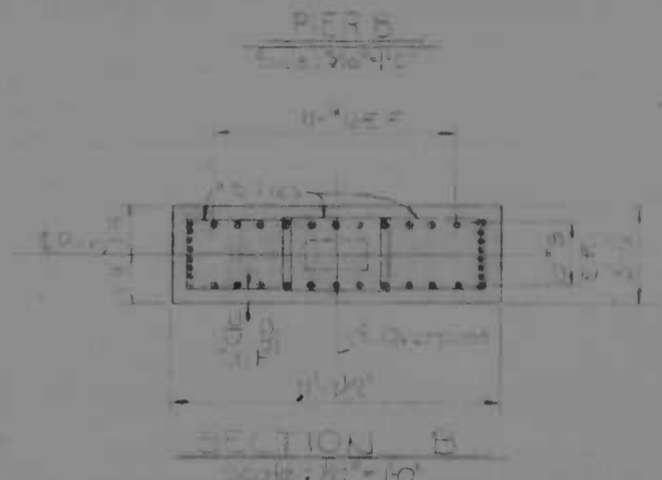

SECTION B
Scale: 1/4" = 1'-0"

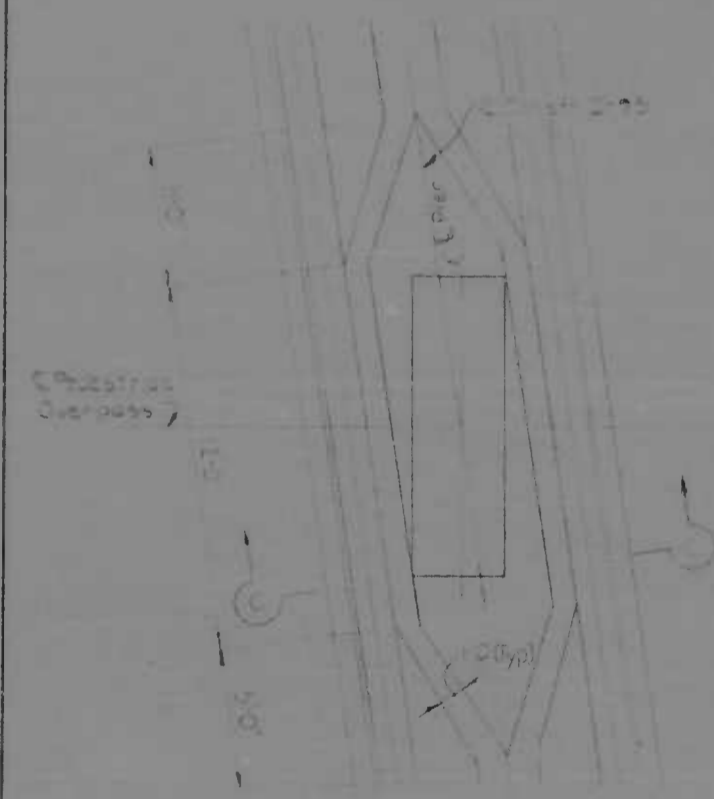

MEDIAN UNDERDRAIN
TREATMENT @ PIER 8
Scale: 1/4" = 1'-0"

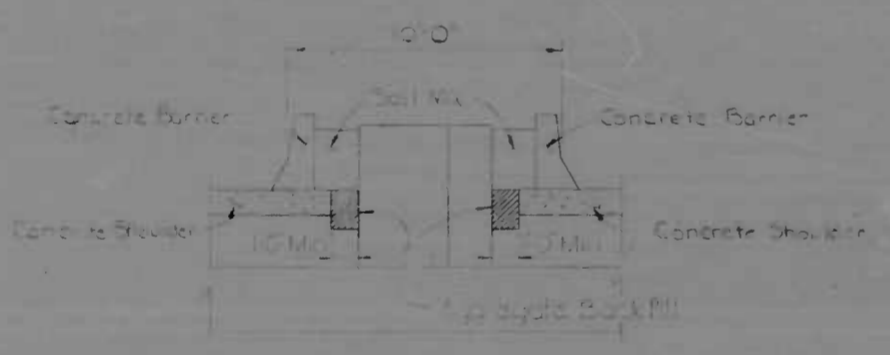

SECTION C
Scale: 1/2" = 1'-0"

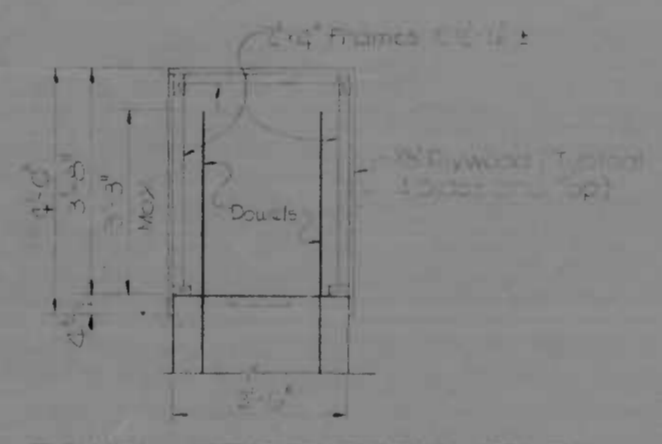

DOWEL PROTECTION COVER
Scale: 1/2" = 1'-0"

NOTES:
1. See General Notes and Dwg #79.
2. Soil bearing pressure used in design of footings is 2 tons/sq ft.

REVISIONS 1. Add 1/2" Reinforcement for Pedestrian Deck (See Note 1) 2/1/80	CONSULTANT KIMBERLIE DESIGN PARTNERS & ASSOC., INC. 1001 W. BALTIMORE ST., SUITE 100 BALTIMORE, MARYLAND 21201	CITY OF BALTIMORE DEPARTMENT OF PUBLIC WORKS &		STATE ROADS COMMISSION OF MARYLAND INTERSTATE DIVISION FOR BALTIMORE CITY	
		EASTERN AND WESTERN PIERS		DRAWN BY CHECKED BY DATE	DESIGNED BY CHECKED BY DATE

NO.	DATE	BY	REVISION
2	MD, I-95-43238	LD	US

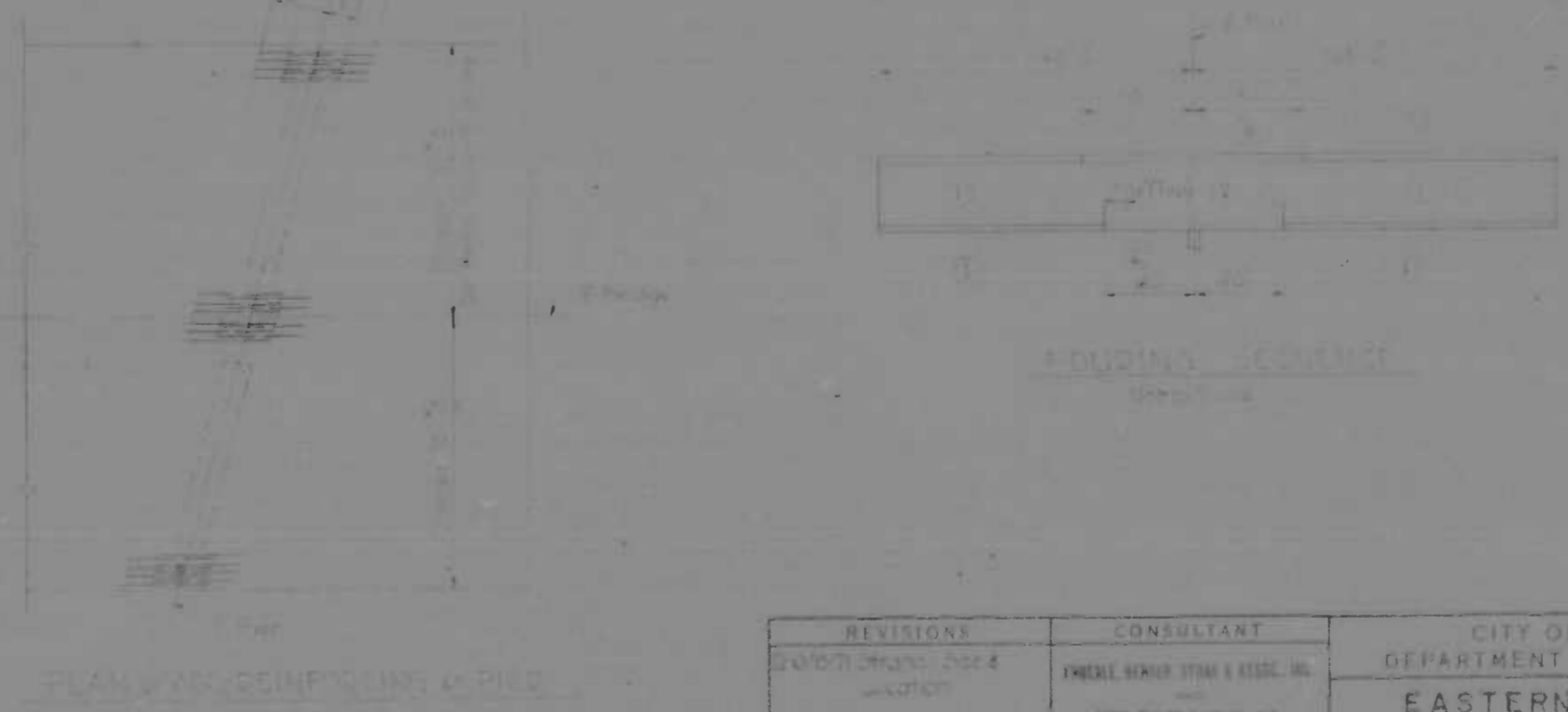
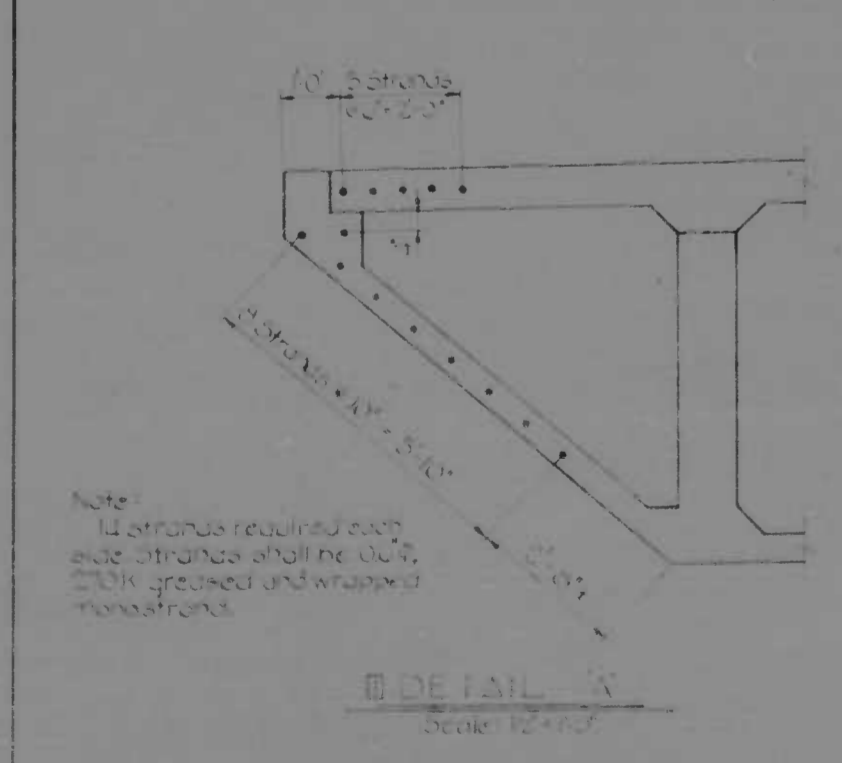
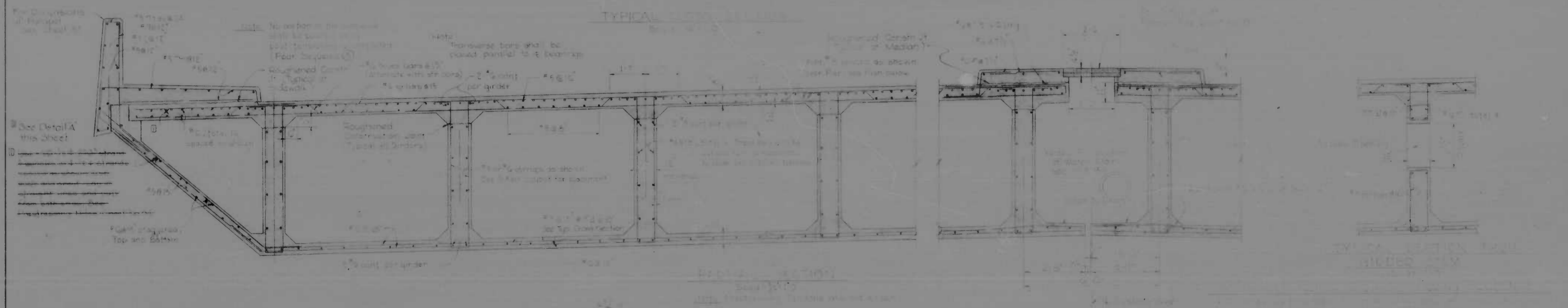
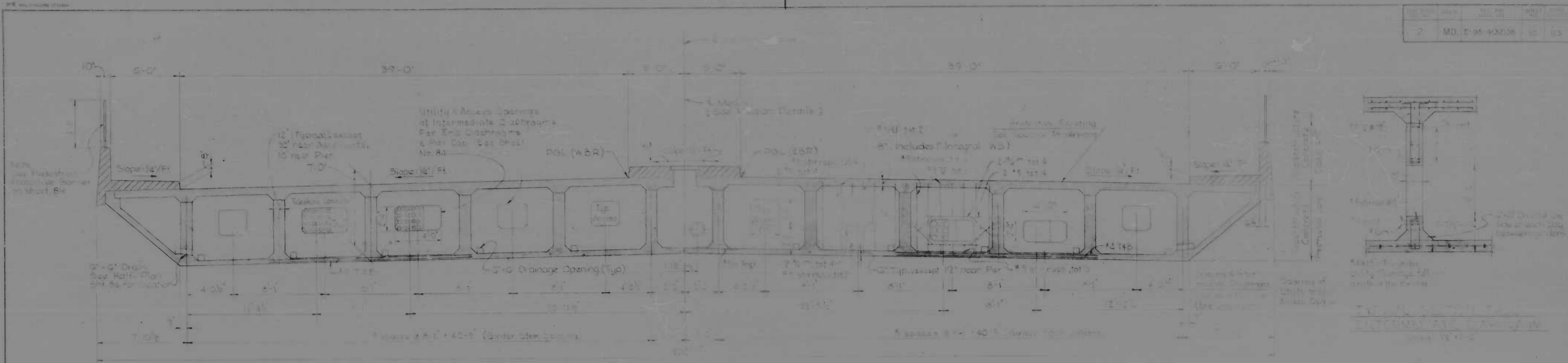

Notes regarding construction and materials, including references to specifications and other drawings.

REVISIONS	CONSULTANT	CITY OF BALTIMORE DEPARTMENT OF PUBLIC WORKS	STATE ROADS COMMISSION OF MARYLAND INTERSTATE DIVISION FOR BALTIMORE CITY
2000.07.01.004 SECTION	EMERLE BAKER STONE & ASSOC. INC. 400 SOUTH BALTIMORE STREET BALTIMORE, MARYLAND 21201	EASTERN AVE OVER I-95 TYPICAL SECTION	DRAWN BY: [] DESIGNED BY: [] CHECKED BY: [] DATE: AUG 1989
		SCALE: AS NOTED	SHEET NO. 113

12/11/89 4:02 PM

FED. ROAD DIST. NO.	STATE	PROJ. NO.	SHEET NO.	TOTAL SHEETS
2	MD	I-95-43236	86	113

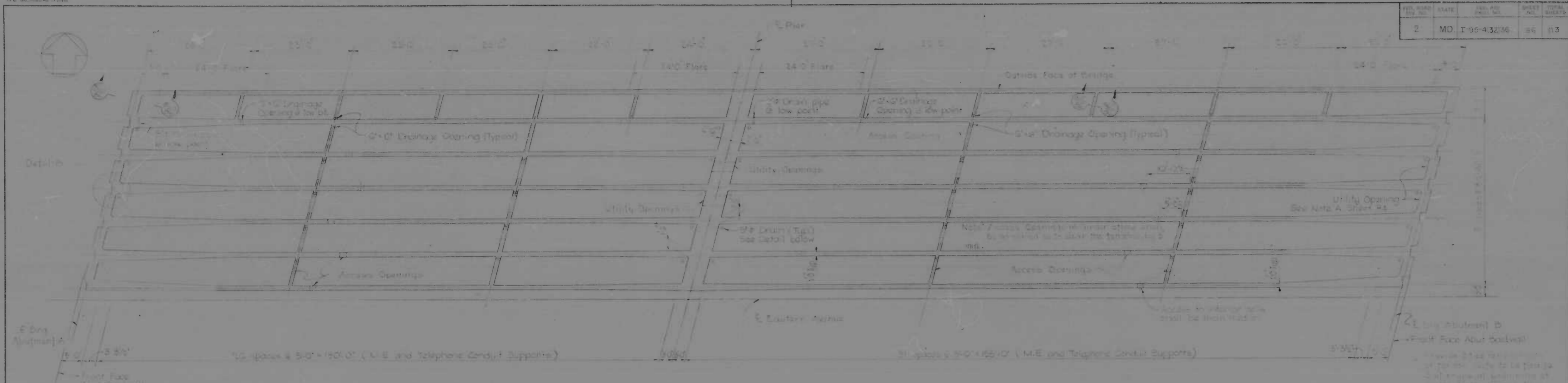

HALF PLAN
Scale: 1/4" = 1'-0"

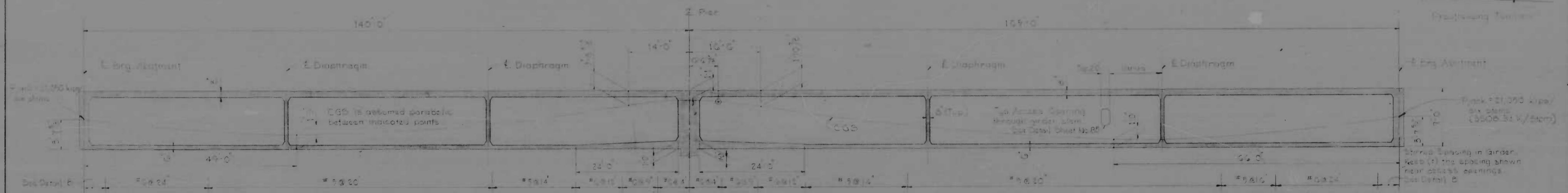

LONGITUDINAL SECTION
Scale: Horiz. 1/4" = 1'-0"
Vert. 1/8" = 1'-0"

- POST-TENSIONING / POSTSTRESSING NOTES**
- Block - 11,000 lbs total of jacking and prestressing force. Block to be stressed in 2 days. For 11,000 lbs of prestressing force, use 270 # strands (100 # strands @ 47 # additional prestressing force to be added to 270 # strands). Contractor to provide 100 # of strands. All strands shall be stressed simultaneously and final stress (jacking will be completed from both ends).
- CONCRETE: Fc = 5000 psi @ 28 days, Fc = 4000 psi @ time of stressing.
- POSTSTRESSING STEEL: The prestressing steel shall be located in the girder spans with an equal force in each span. At the Contractor's option the prestressing force may vary to 1/8" from the theoretical equal force per girder provided the total Block is obtained and the force is distributed symmetrically about the centerline of the typical section. Units are to be tensioned a few of a time in each span to minimize stress differential.
- CLEARANCE: (1) Horizontal clearance between tendons 2 1/2" min.
(2) 1 1/2" min. if bundled vertically in groups of 3 max.
(3) Vertical clearance between horizontal tendons 3" min.
- GENERAL: (1) Block specified at the jacking ends includes trapezoidal voids and provision for 25,000 psi loss in stress.
(2) Tendons to be jacked to 0.80 Fc and anchored against (a) 3.75 Fc max. and (b) 1000 psi max. (c) 1000 psi max. (d) 1000 psi max.
(3) Design is based on a 2.5% and 4.0% loss. Contractor to submit schedule and jacking calculations including a 2.5% and 4.0% loss and initial stress of 0.80 Fc times jacking stress.
(4) Devote to the job at least 100 # of strands.
(5) Encapsulate steel near great faces at both ends and at voids (draw on the drawing) and seal with concrete.
(6) During jacking operations, the contractor shall use an internal pressure with hose pressure to check against tendon slippage and excessive friction. For reinforcement interfering with the prestressing tendon alignment shall be cut out as directed by the Engineer.

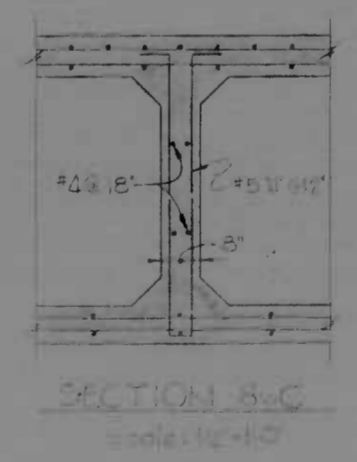

SECTION B-C
Scale: 1/2" = 1'-0"

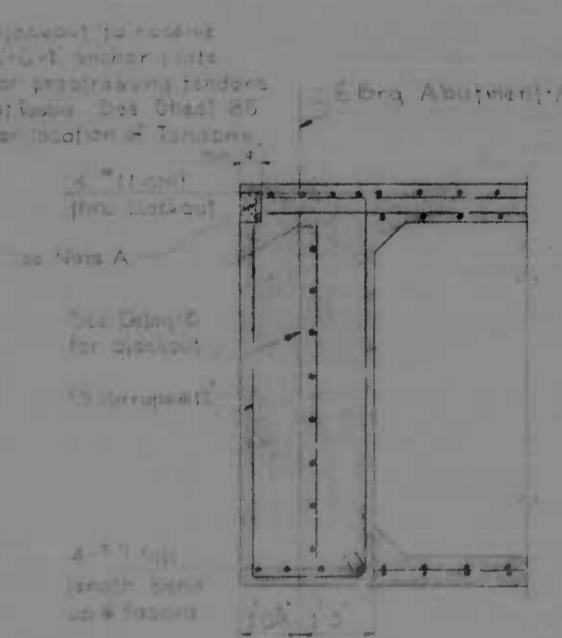

SECTION A-A
Scale: 1/2" = 1'-0"

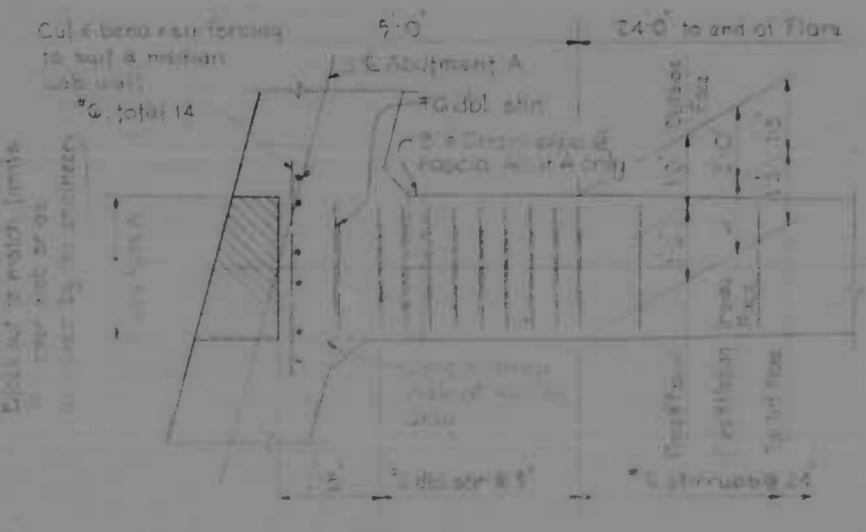

DETAIL - B
Scale: 7/8" = 1'-0"

After all stressing has been done and anchors removed, clean off excess grout if behind and patch cover and plates with non-shrink grout. Procedures to be filed before jacking backfill.

REVISIONS	CONSULTANT	CITY OF BALTIMORE DEPARTMENT OF PUBLIC WORKS & EASTERN AVE. OVER I-95 GIRDER LAYOUT	STATE ROADS COMMISSION OF MARYLAND INTERSTATE DIVISION FOR BALTIMORE CITY
	KNERLE, BENDER, STONE & ASSOC., INC. RATZ, CHONG & ASSOC., INC. CONSULTING ENGINEERS 301 N. CALVERT STREET BALTIMORE, MARYLAND 21202	SCALE: AS NOTED DATE: AUG 1969	DRAWN BY: [Signature] TRACED BY: [Signature] F.A.P. NO. I-95-43236 S.R.C. NO. MS 246-26-619 BALTO. CITY NO. 1959

REV. NO.	DATE	BY	CHK.
2	MD. I-95-432136	87	113

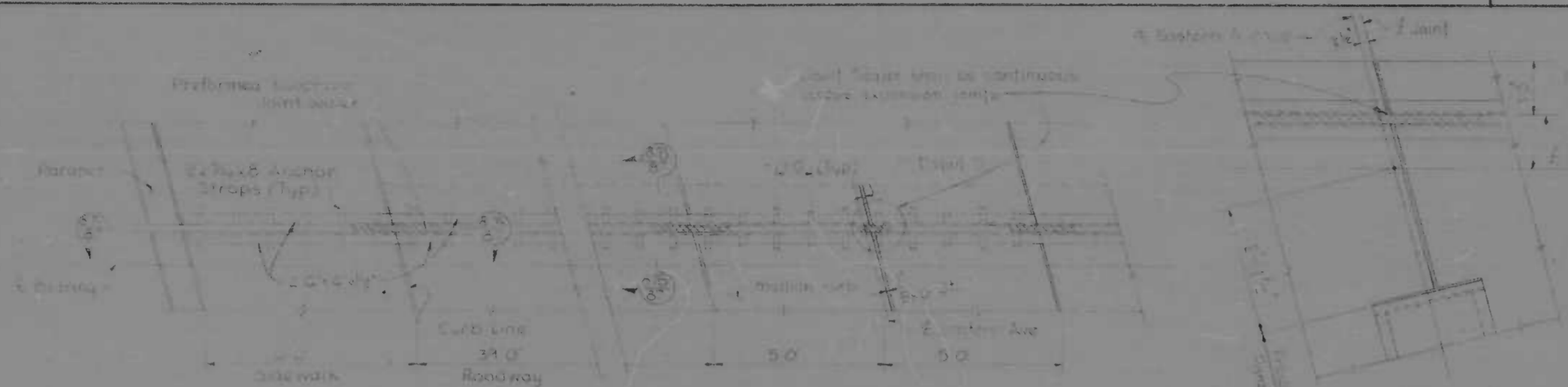

PARTIAL PLAN AT ABUTMENT
Scale 1/4"=1'-0"

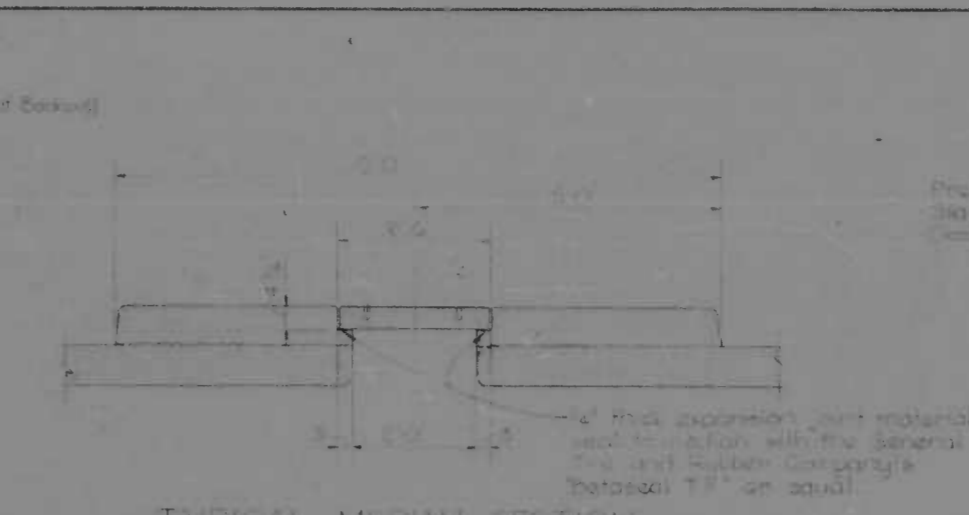

TYPICAL MEDIAN SECTION
Scale 1/4"=1'-0"

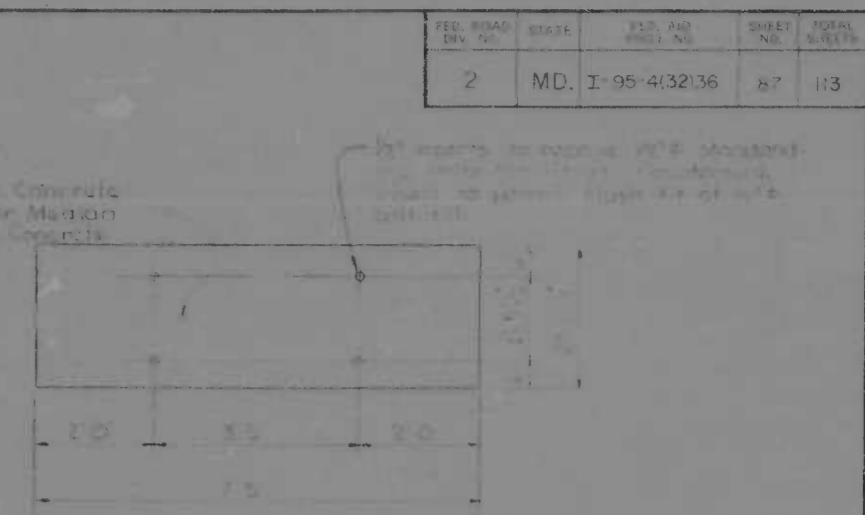

PRECAST LIFT PANELS
Scale 1/4"=1'-0"

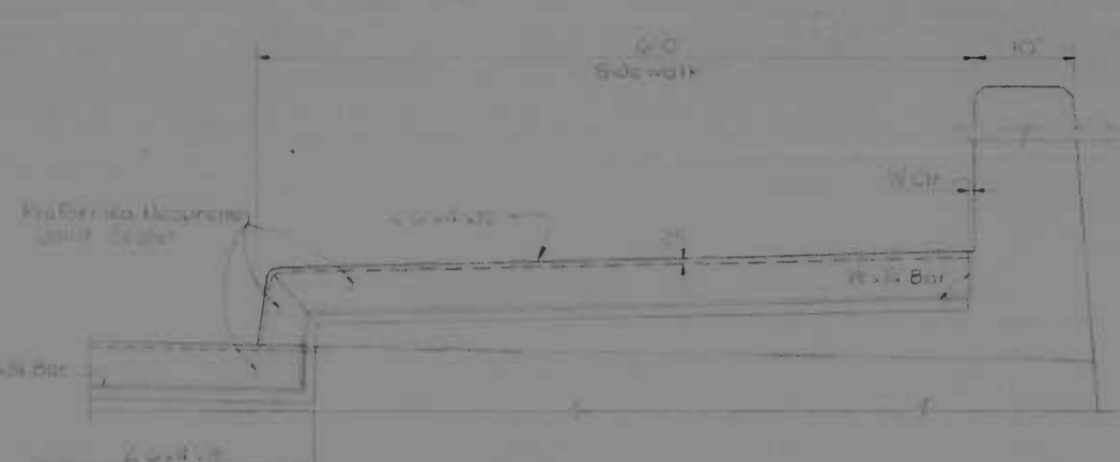

SECTION 87A
Scale 1/4"=1'-0"

Note: Contractor may use 1/2" Port II instead of 1/2" x 1/2" over sidewalk and abutment.

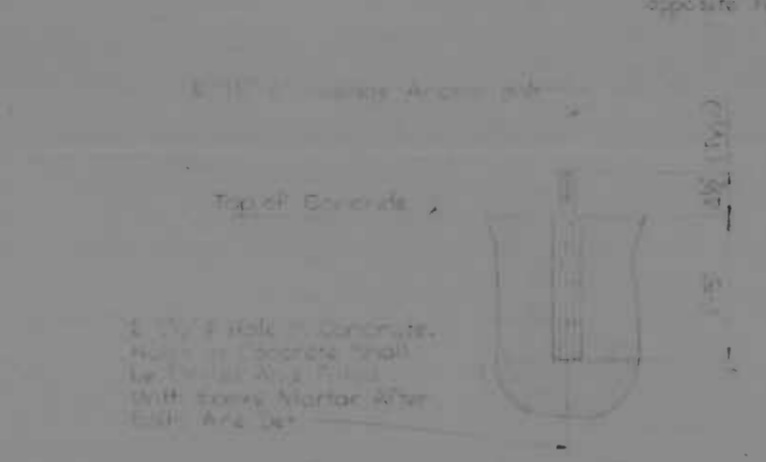

DRILLING & GROUTING DETAIL
Scale 1/4"=1'-0"

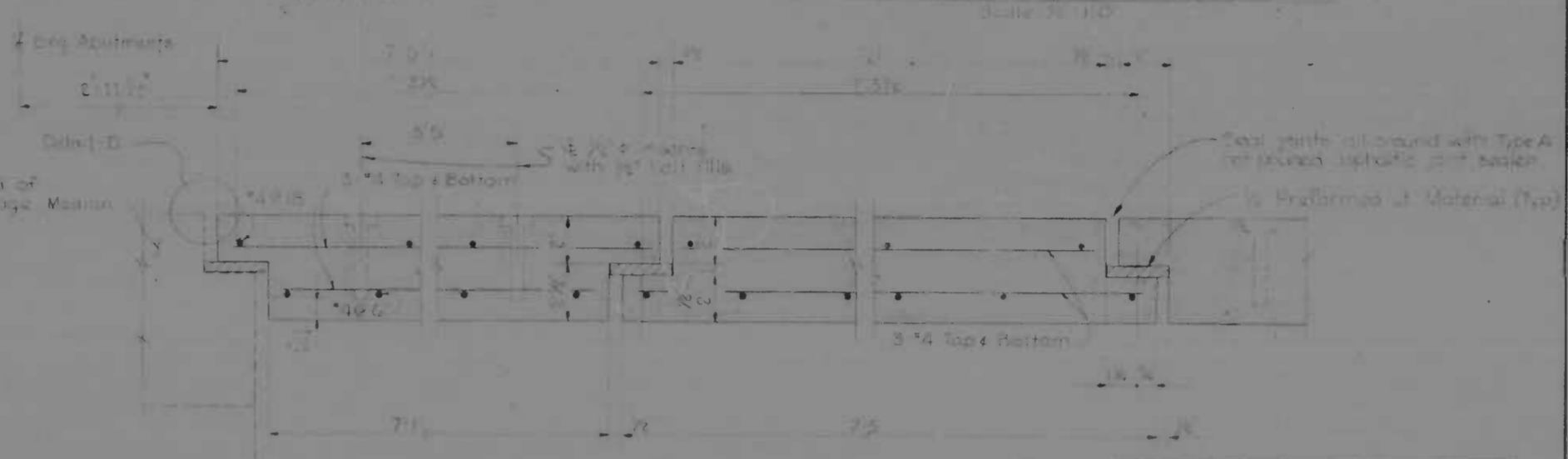

TYPICAL SECTION OF LIFT PANELS
Scale 3/4"=1'-0"

PRECAST LIFT PANELS
21 panels with 21 joints
20 panels without joints



PREFORMED JOINT SEALER
Not to Scale

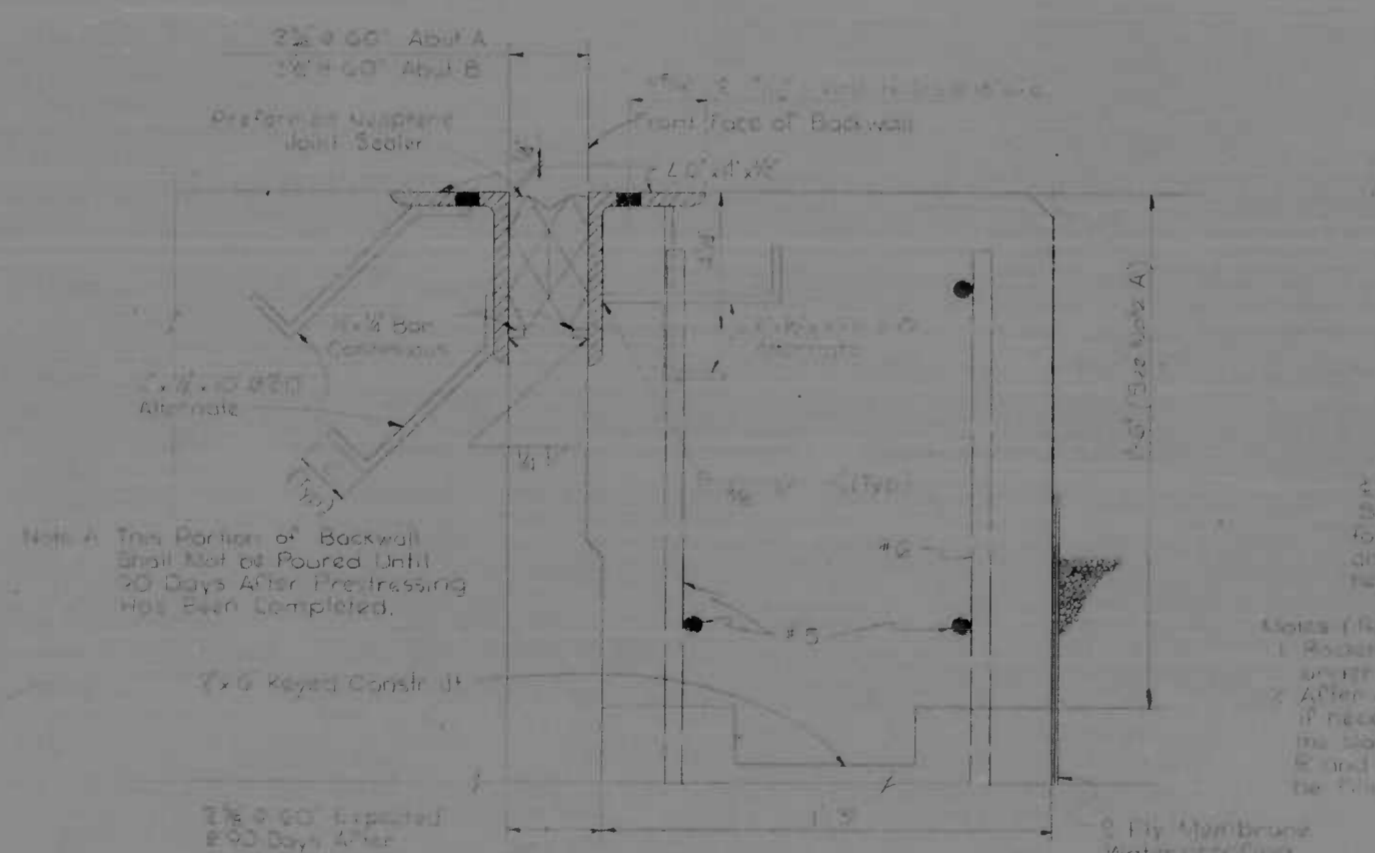

SECTION 87B
Scale 3/4"=1'-0"

Note A: This portion of Backwall shall not be poured until 90 days after prestressing has been completed.

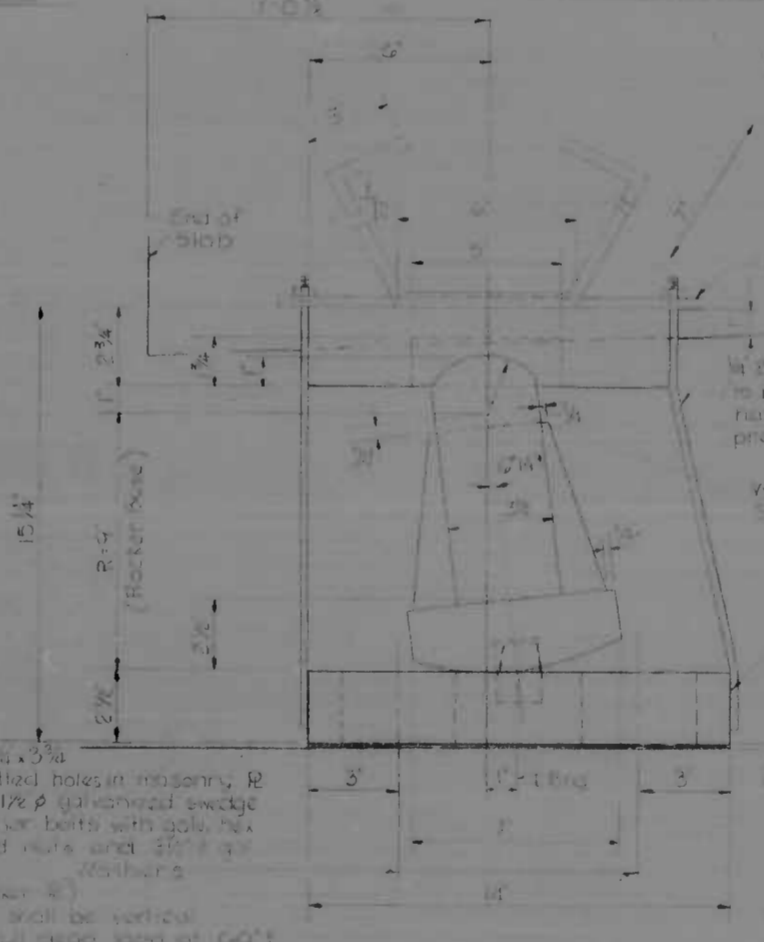

SECTION 87C
Scale 3/4"=1'-0"

Note: (Rocker) 1. Rockers shall be vertical unless noted. 2. After adjusting fill of Rockers, if necessary the space between the slotted holes in the masonry and the anchor bolts shall be filled with epoxy mortar.

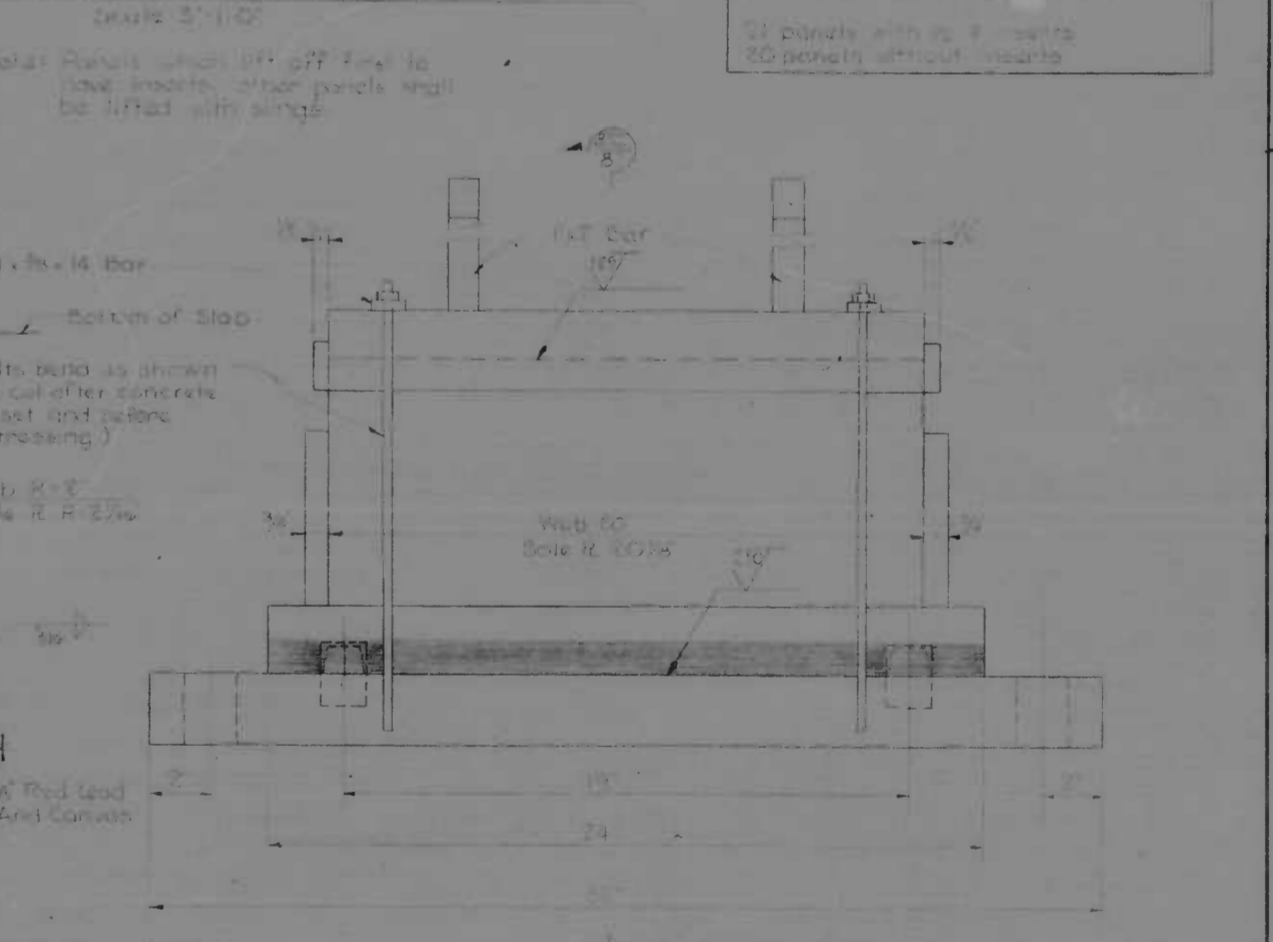

ROCKER DETAIL
Scale 3/4"=1'-0"

Note: 1. All bearing assemblies to be adjusted after erection. 2. Rocker shown in initial position.

ROCKER LOCATING PIN
Scale 3/4"=1'-0"

REVISIONS	CONSULTANT	CITY OF BALTIMORE DEPARTMENT OF PUBLIC WORKS & STATE ROADS COMMISSION OF MARYLAND INTERSTATE DIVISION FOR BALTIMORE CITY	
	KNORRLE, BENDIS, STONE & ASSOC., INC. AND MATZ, CHLOS & ASSOC., INC. CONSULTING ENGINEERS 341 N. CALVERT STREET BALTIMORE, MARYLAND 21202	EASTERN AVE. OVER I-95 SLAB AND BEARING DETAILS	
		SCALE: AS NOTED	DATE: AUG 1963

REV. NO.	DATE	BY	CHECKED	SHEET NO.	TOTAL SHEETS
2	MD	I-95-43236	88	113	

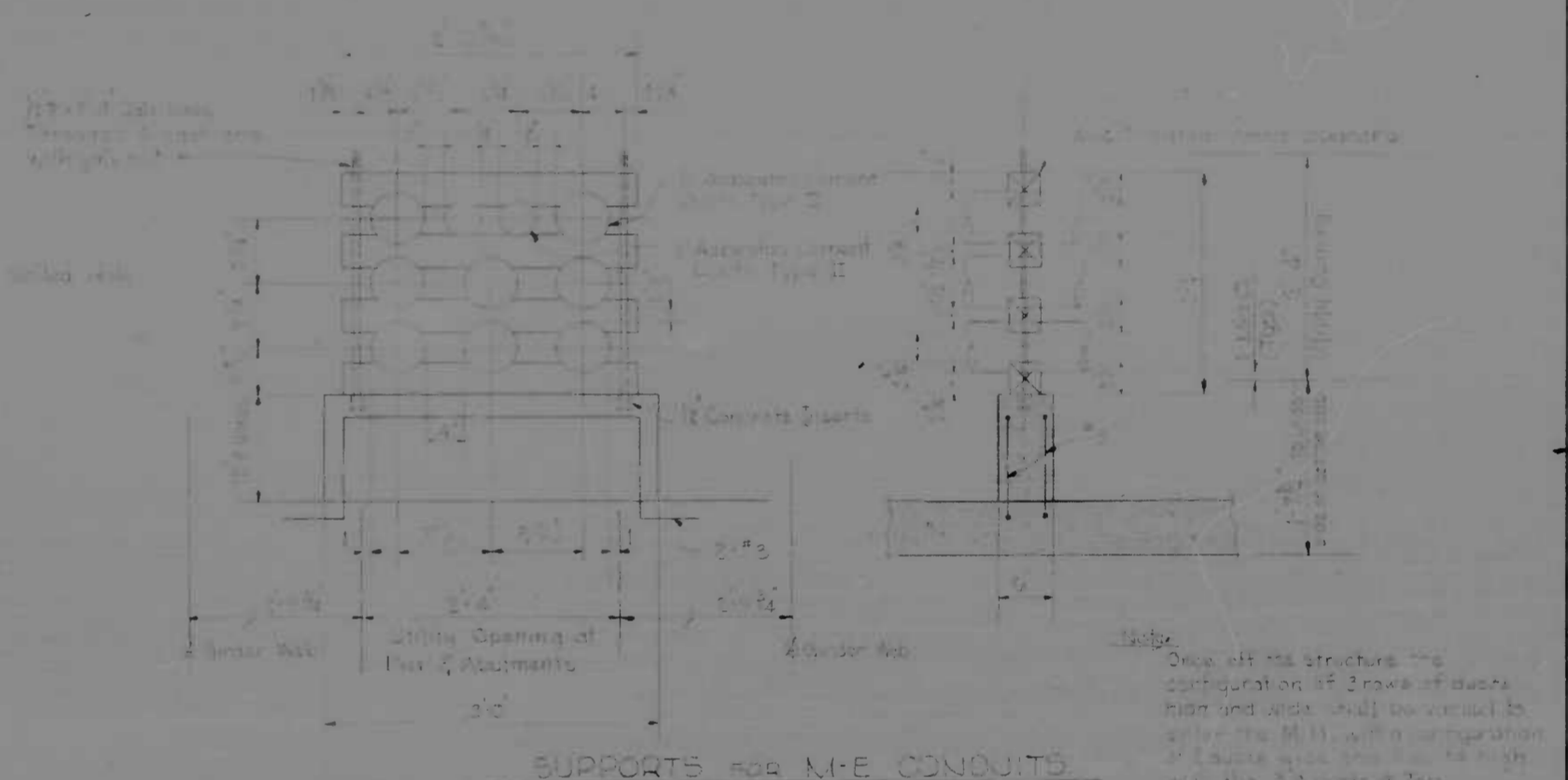
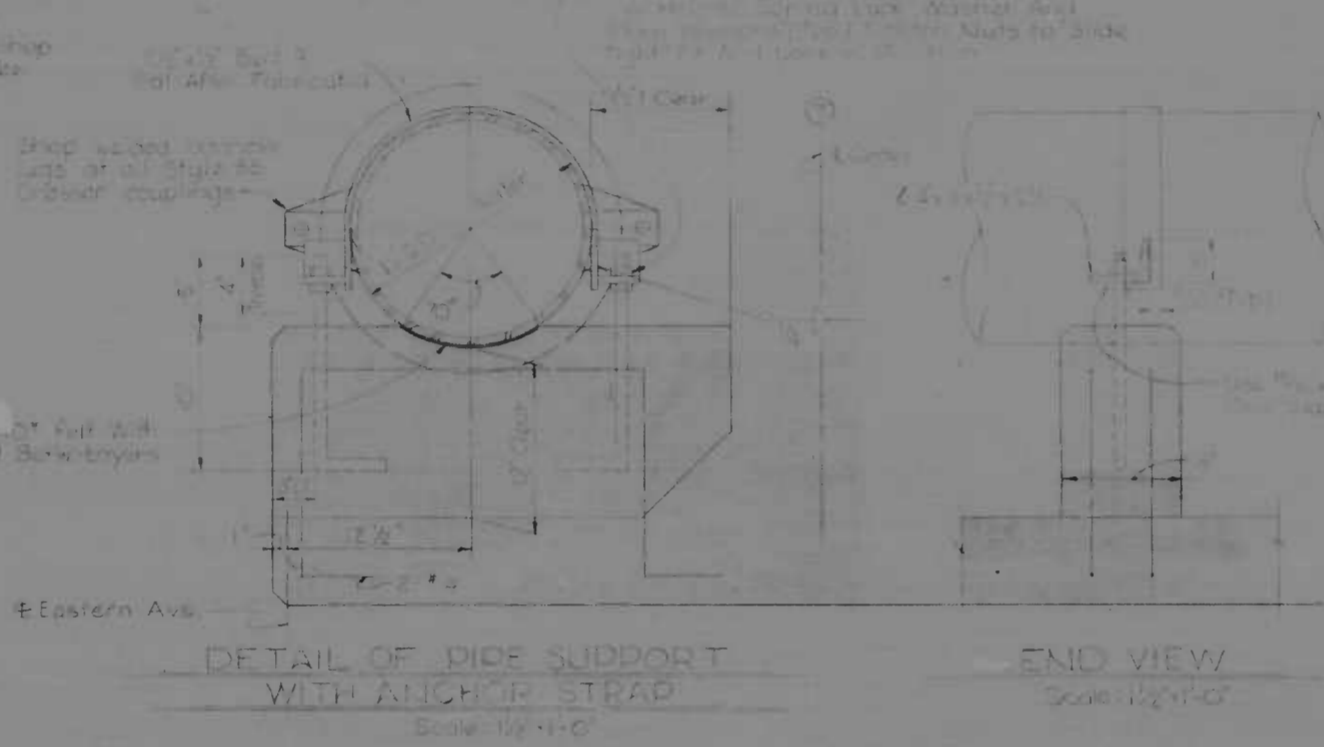
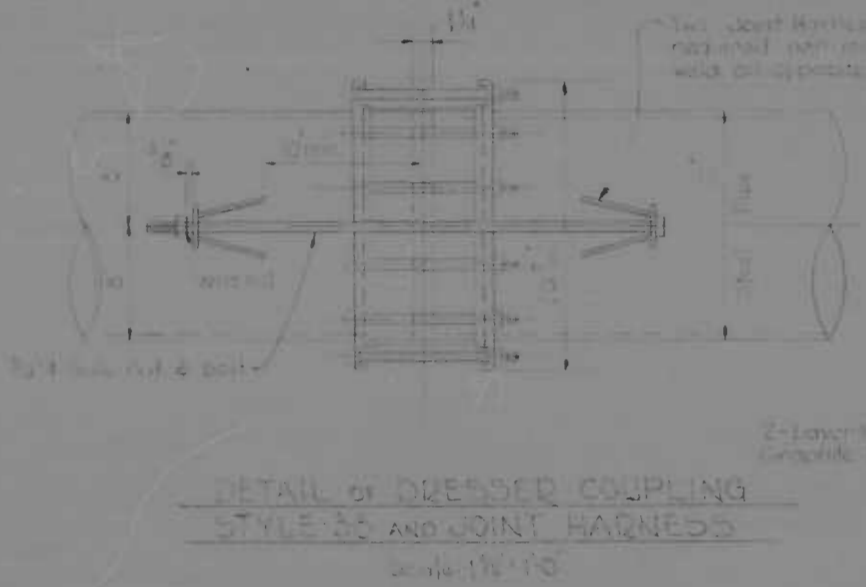
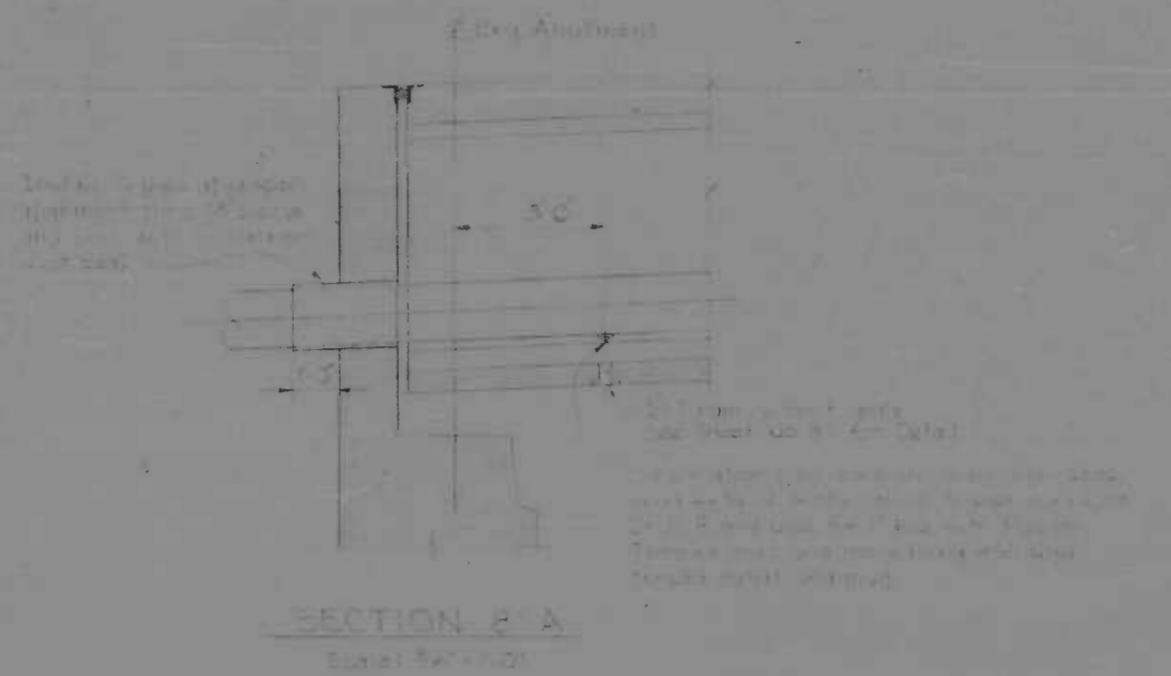
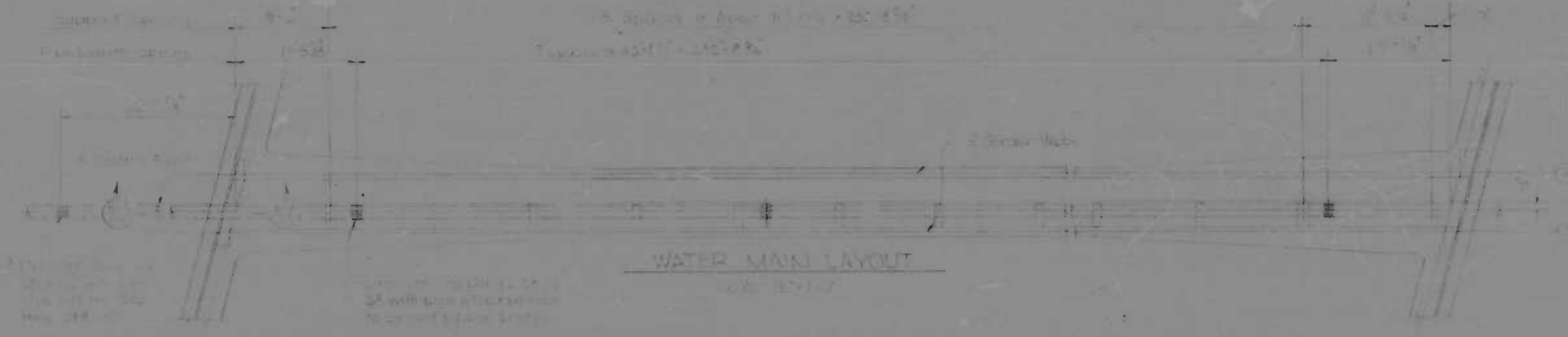

- Notes:**
- All Work to be Done in Accordance with Conditions and/or Revisions to the Specifications for the Interstate Highway System in Baltimore City.
 - Steel Pipe shall have 40 Foot Lengths and a Nominal Wall Thickness of 1/2 inch and shall be suitable for a Test Pressure of 200 psi.
 - Steel Pipe shall be in Accordance with A.W.W.A. Spec. C-102-50. Interior of Pipe shall be lined with Coal Tar Enamel. In no case shall the Pipe Lining be Disturbed by Welding.
 - Approprials shall be as Manufactured by Dresser Manufacturing Division of Dresser Industries or Approved Equal. Couplings shall be furnished with a Inside Ring 7 inches in length and 1/2 inch Thick. Remove Center Strap Only on Style 35.
 - Gaskets shall be Dresser Gasket Plain Grade 27 or Approved Equal.
 - Joint Opening of 1/8 inch Gasket shall be 1/8 inch with Coupling Centered on Joint.
 - All Pipe Joints Within the Bridge Structure, the Pipe Ends shall be hardened. See Joint Hardness Detail This Sheet.
 - Notes on Higher Road shall be Ignored in a Manner That will Prevent Pipe from Sinking.

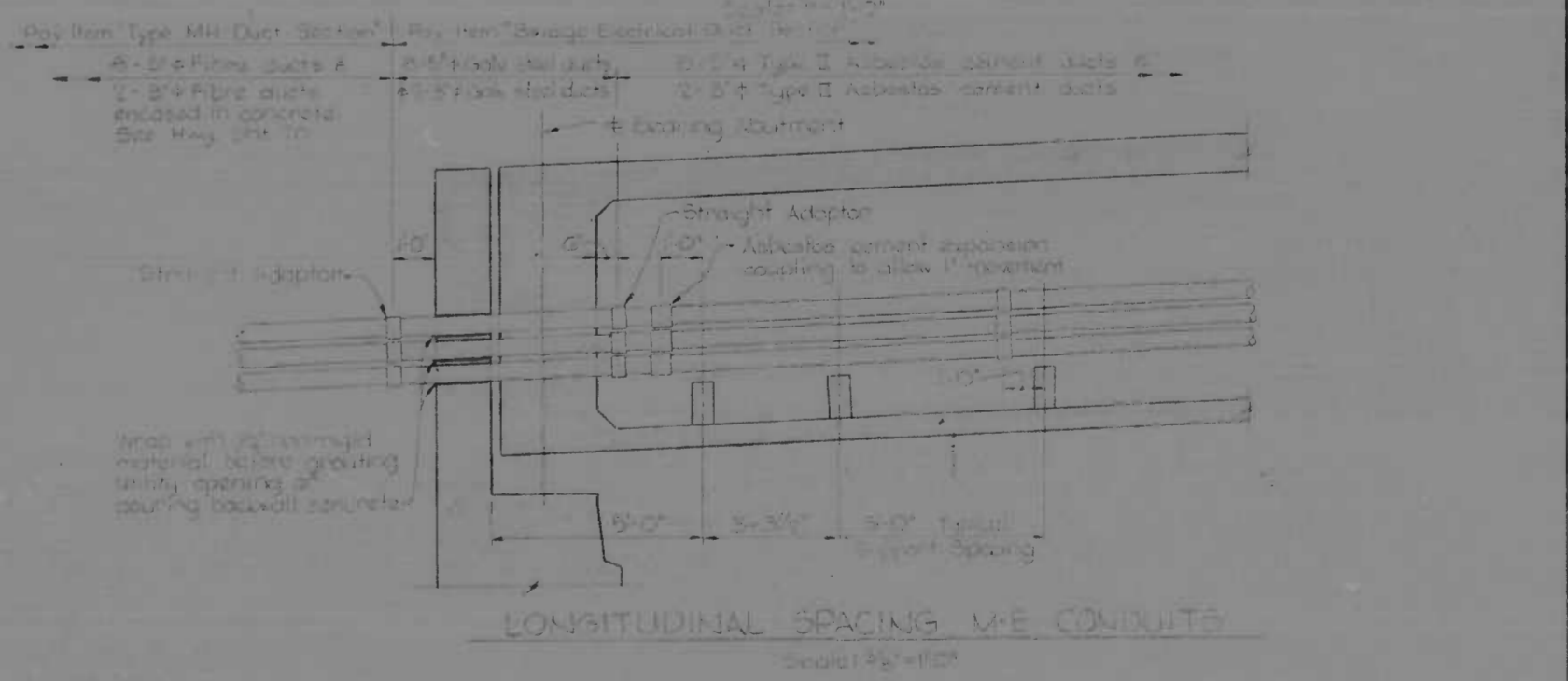

REVISIONS	CONSULTANT	CITY OF BALTIMORE DEPARTMENT OF PUBLIC WORKS	STATE ROADS COMMISSION OF MARYLAND INTERSTATE DIVISION FOR BALTIMORE CITY
	KROGER, PENNER, STINE & ASSOC., INC. MATZ, CURTIS & ASSOC., INC. CONSULTING ENGINEERS 381 N. CALVERT STREET BALTIMORE, MARYLAND 21202	EASTERN AVE. OVER I-95 MISCELLANEOUS DETAILS	DRAWN BY: [Signature] TRACED BY: [Signature] F.A.P. NO. I-95-43236 S.R.C. NO. BC 246-26-815 BALTO. CITY NO. 1959
		SCALE: AS NOTED	DATE: AUG 1959
			DES. BY: [Signature] CHK. BY: [Signature] SHEET NO. 88 OF 113

12/11/65 4/18/76

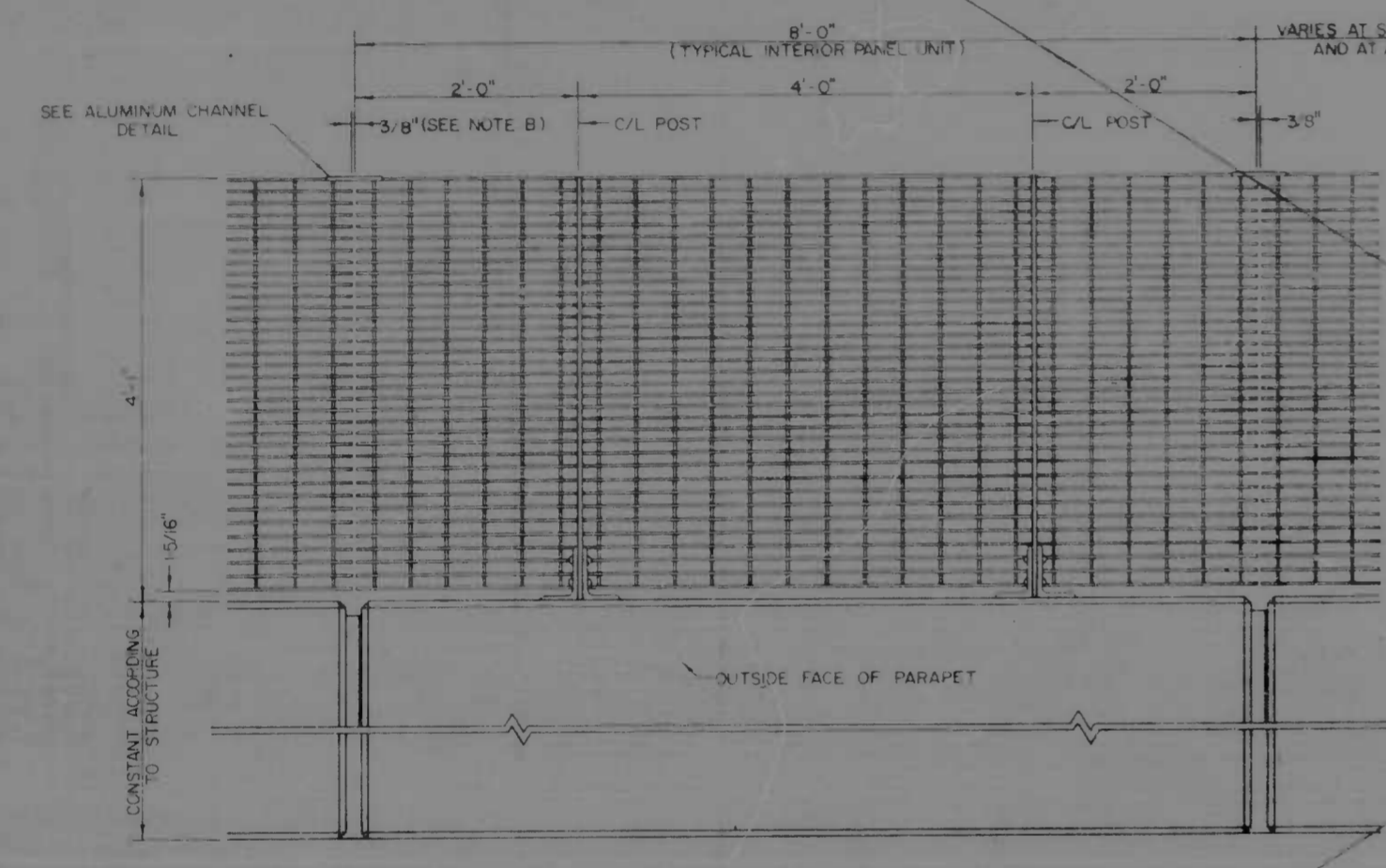
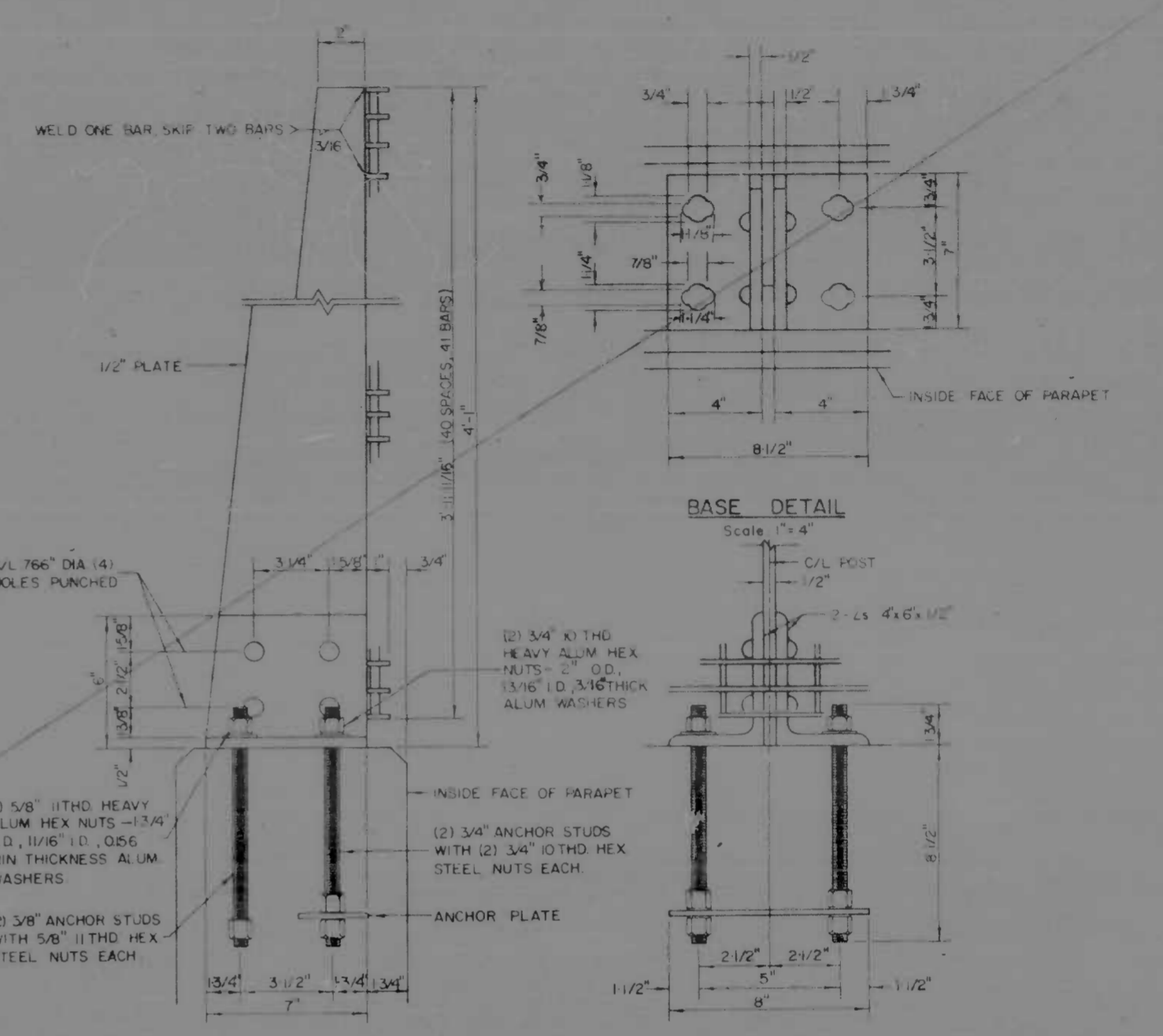
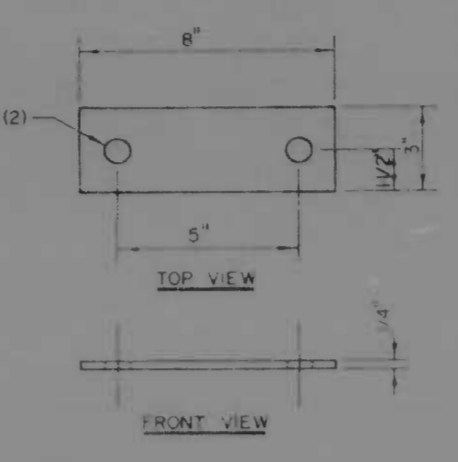
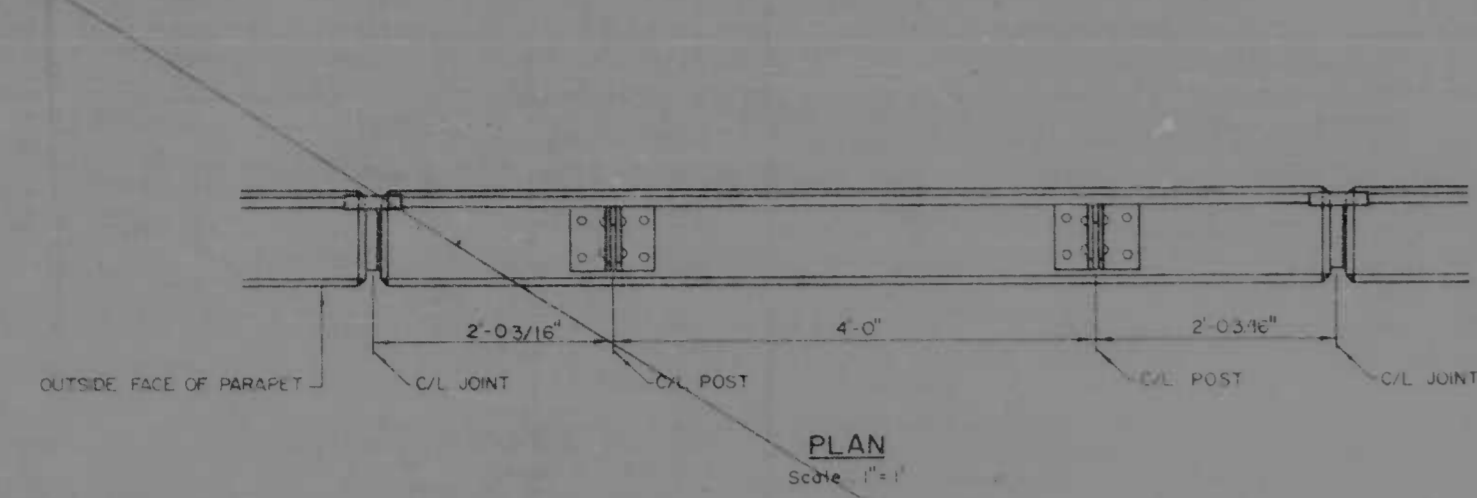

NOTE *
VARIABLE UNITS SHALL BE DEVELOPED IN ACCORDANCE WITH THE FOLLOWING CRITERIA:
A PANEL UNIT OF 6' TO 9' SHALL HAVE (2) POSTS SPACED AT 2'-0 3/16"
A PANEL UNIT OF 9' TO 14' SHALL HAVE (3) POSTS SPACED AT 2'-0 3/16"

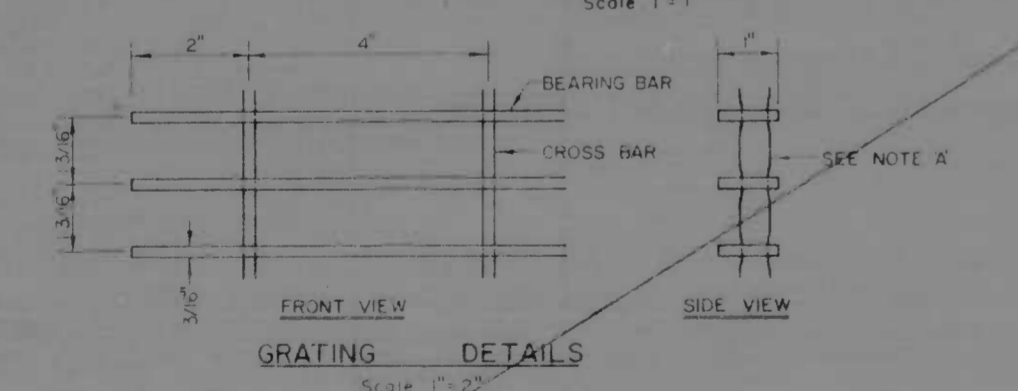
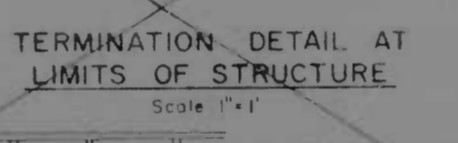

NOTE A
CROSS BARS TO BE PRESSURE LOCKED TO BEARING BARS. SIZE AND CONFIGURATION TO BE APPROVED BY THE ENGINEER. CROSS BARS TO BE OFFSET TO OUTSIDE OF PARAPET.

NOTE B
3/8" BARRIER JOINT IS TYPICAL EXCEPT AT EXPANSION JOINTS AT ABUTMENTS AND/OR PIERS. AT THE ABUTMENTS AND/OR PIERS, THE BARRIER JOINT SHOULD EQUAL THE EXPANSION JOINT.

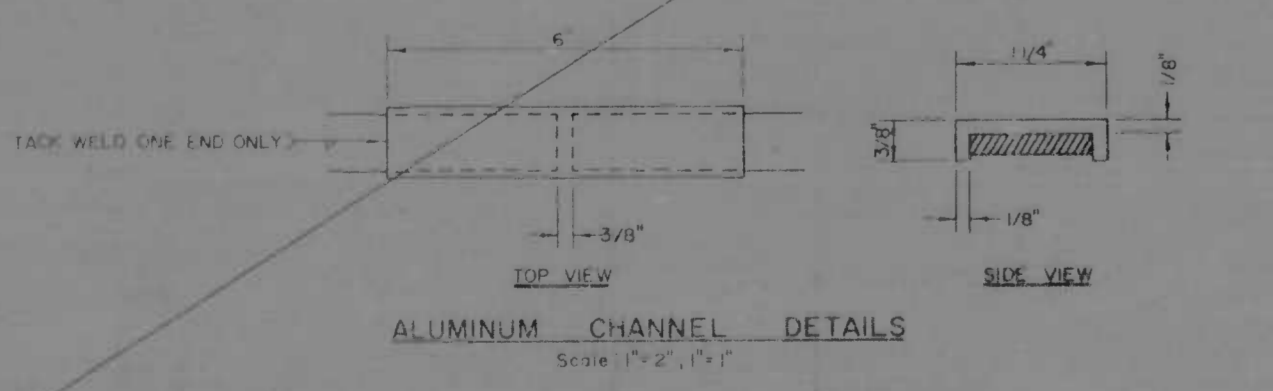
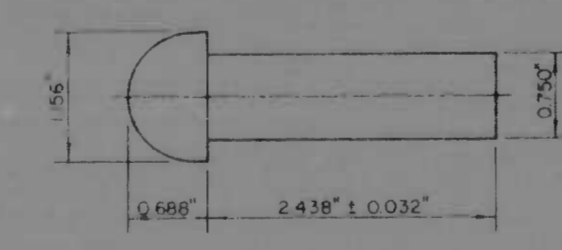

GENERAL NOTES

POSTS TO BE SET PERPENDICULAR TO TOP OF PARAPET. SEE CONTRACT DRAWINGS FOR POST SPACING *

MATERIALS FOR PROTECTIVE BARRIER:

1. BASE ANGLES SHALL CONFORM TO A.S.T.M. DESIGNATION B-221 ALLOY 6061-T6. THEY SHALL HAVE A MILL FINISH EXCEPT THAT ANY SAWED SURFACES SHALL HAVE A SURFACE COMPARABLE TO 250 MICRO-INCH.
2. ANCHOR STUDS SHALL CONFORM TO A.S.T.M. DESIGNATION A-976, TYPE 430 STAINLESS STEEL, ANNEALED, HOT FINISHED, ULTIMATE STRENGTH 70,000 PSI MIN, AND 20% MIN ELONGATION. THREADS TO BE ROLLED AND NOT CUT.
3. ALUMINUM NUTS SHALL CONFORM TO A.S.T.M. DESIGNATION B-211, ALLOY 6061-T6 OR ALLOY 6262-T9.
4. ALUMINUM WASHERS SHALL CONFORM TO A.S.T.M. DESIGNATION B-209, ALLOY ALCLAD 2024-T4.
5. ALUMINUM POSTS SHALL CONFORM TO A.S.T.M. DESIGNATION B-316, ALLOY 6061-T6.
6. RIVETS SHALL CONFORM TO A.S.T.M. DESIGNATION B-316, ALLOY 6061-T6 AND 6063-T6 FOR CHEMICAL COMPOSITION ONLY, AND SHALL CONFORM TO MIL-R-1150A IN ALL OTHER RESPECTS. THESE RIVETS SHALL BE BUTTON HEAD AND SHALL BE COLD DRIVEN.
7. STEEL NUTS SHALL CONFORM TO A.S.T.M. DESIGNATION A-307.
8. GRATING - BEARING BARS SHALL CONFORM TO A.S.T.M. DESIGNATION B-211, ALLOY 6063-T6. CROSS BARS SHALL CONFORM TO A.S.T.M. DESIGNATION B-211, ALLOY 6063-T5. GRATING SHALL HAVE A STANDARD MILL FINISH. ALL EXPOSED AND/OR SAWED EDGES SHALL BE GROUND SMOOTH.
9. ALUMINUM CHANNEL SHALL CONFORM TO A.S.T.M. DESIGNATION B-221, ALLOY 6061-T6.
10. ANCHOR PLATES SHALL CONFORM TO A.S.T.M. DESIGNATION A-36.
11. SHIMS, IF REQUIRED, SHALL CONFORM TO A.S.T.M. DESIGNATION B-209, ALLOY 6061-T6.

BOTTOM OF POST BASES AND SHIMS SHALL BE THOROUGHLY COATED WITH AN APPROVED CAULKING COMPOUND OR AN APPROVED ZINC CHROMATE PAINT. ALUMINUM GRATING SHALL HAVE A MINIMUM SQUARE FOOT WEIGHT OF 2.60 LBS./SQ. FT. SHIMS MAY BE REQUIRED UNDER THE BASE ANGLES TO MAINTAIN AN EVEN ELEVATION AT THE TOP OF THE PROTECTIVE BARRIER.

REVISIONS	CONSULTANT	CITY OF BALTIMORE DEPARTMENT OF PUBLIC WORKS &		STATE ROADS COMMISSION OF MARYLAND INTERSTATE DIVISION FOR BALTIMORE CITY	
1. Correct Title Sheet No. 4-1275		EASTERN AVE. OVER I-95		DRAWN BY: M.N.B. DES. BY: K.D.M.	
		PEDESTRIAN PROTECTIVE BARRIER		TRACED BY: D.L.G. CHK. BY: K.D.M.	
		SCALE: AS NOTED	DATE: AUG. 1969	F.A.P. NO. I-95-4132136	SHEET NO. 89 OF 113
				S.R.C. NO. BC 246-25-815	
				BALTO. CITY NO. 1961	

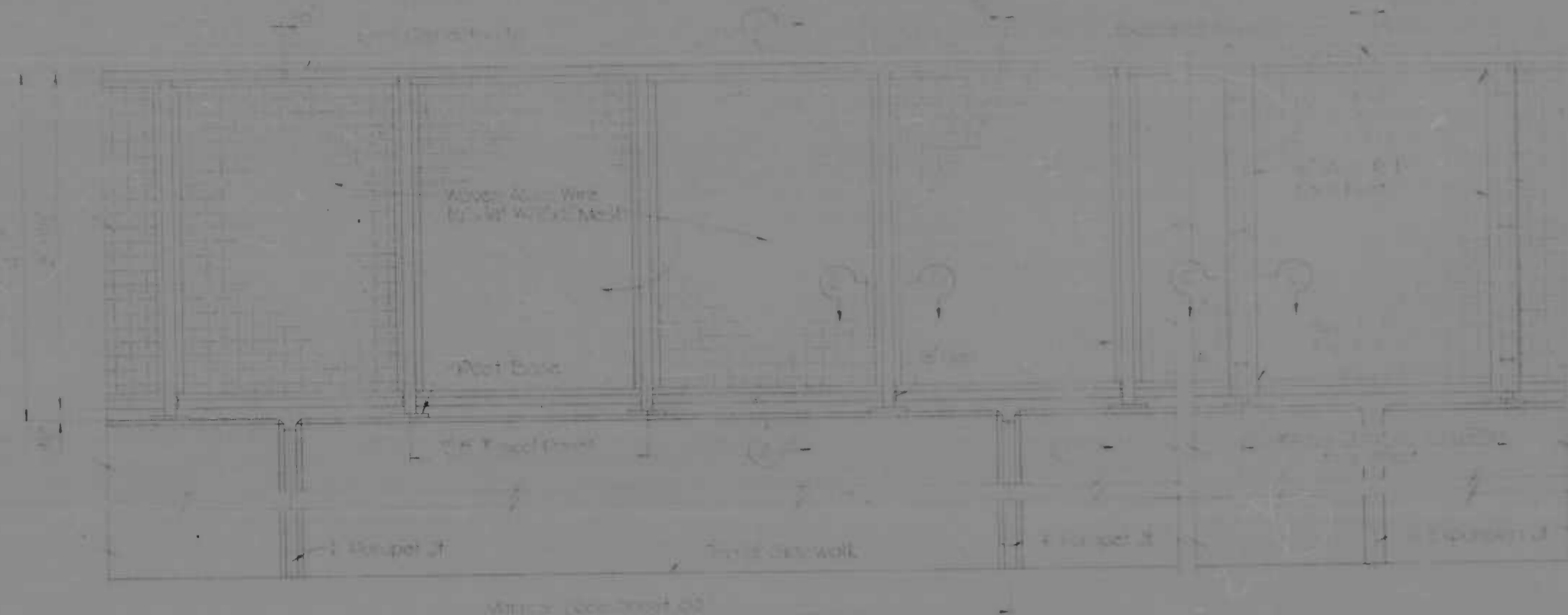

TYPICAL ELEVATION OF PEDESTRIAN BARRIER
Scale 1/4" = 1'-0"

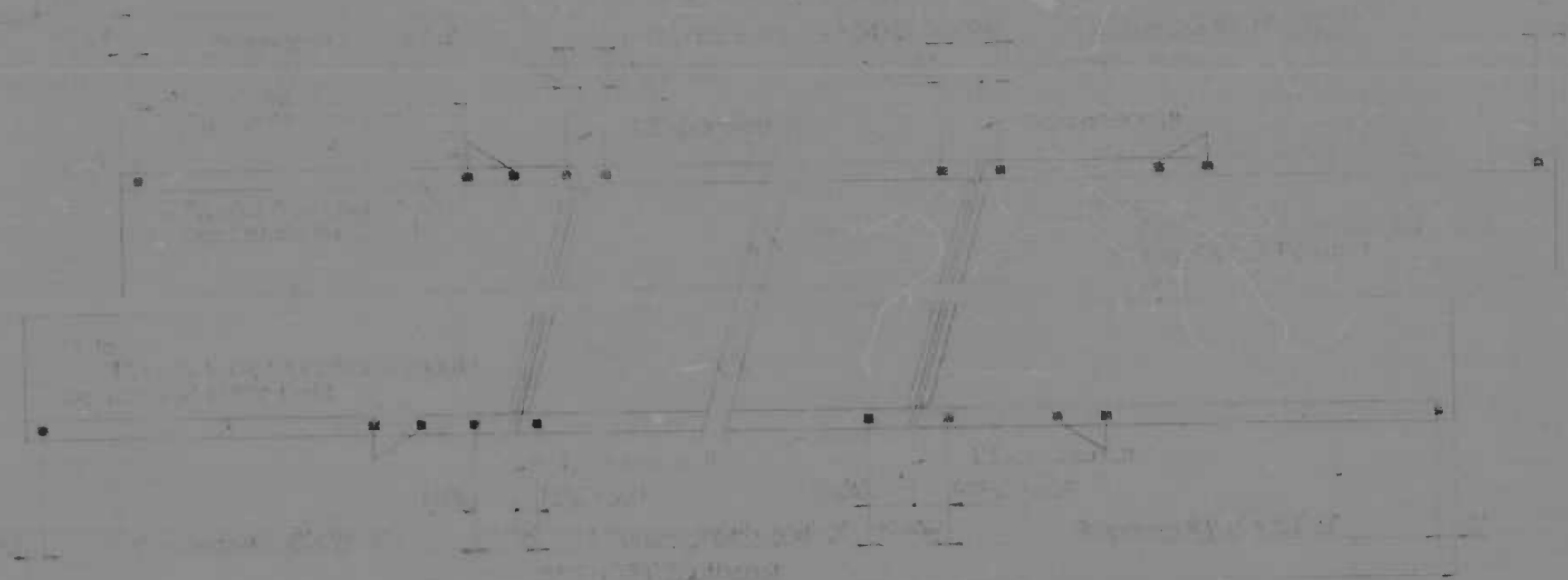

Barrier Plan
Scale 1/4" = 1'-0"

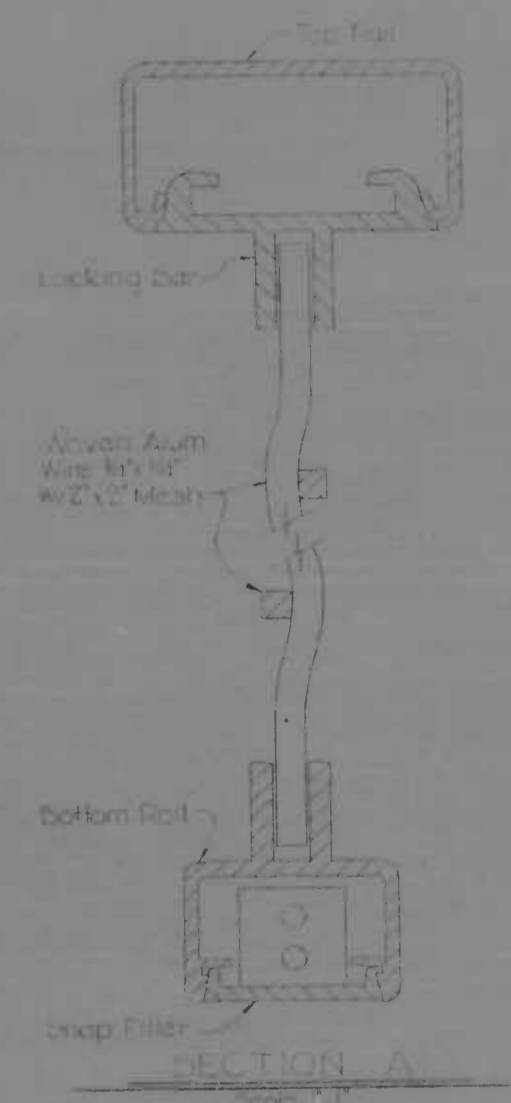

SECTION A
Scale 1/4" = 1'-0"

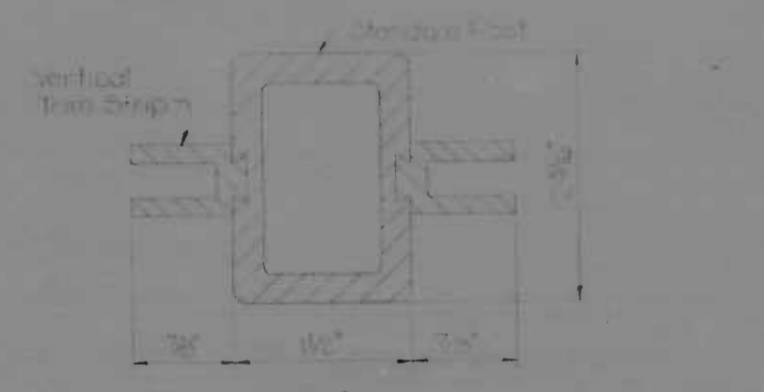

SECTION B
Scale 1/4" = 1'-0"

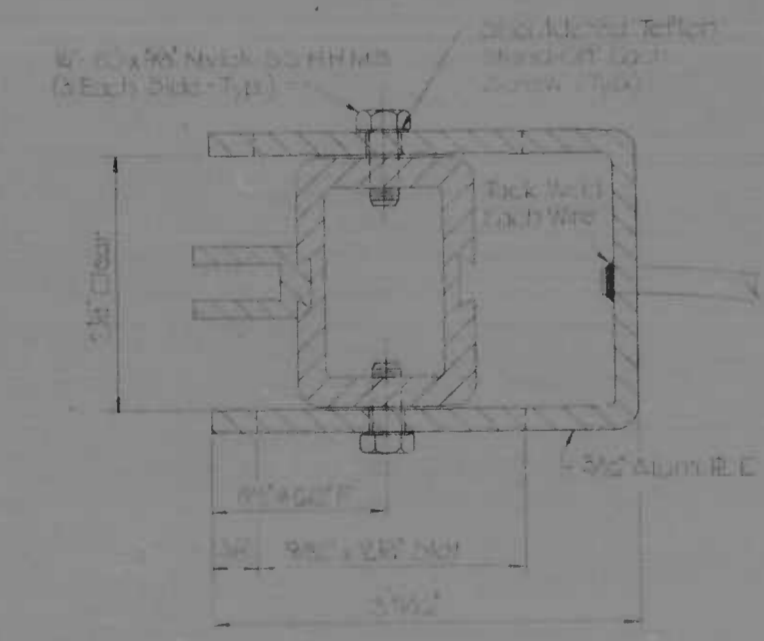

SECTION C
Scale 1/4" = 1'-0"

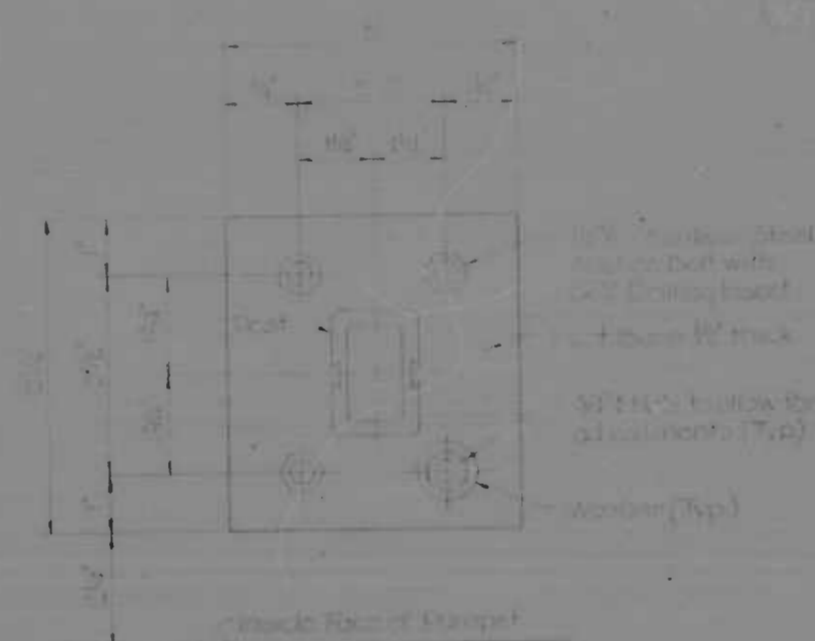

PLAN - POST BASE
Scale 1/4" = 1'-0"

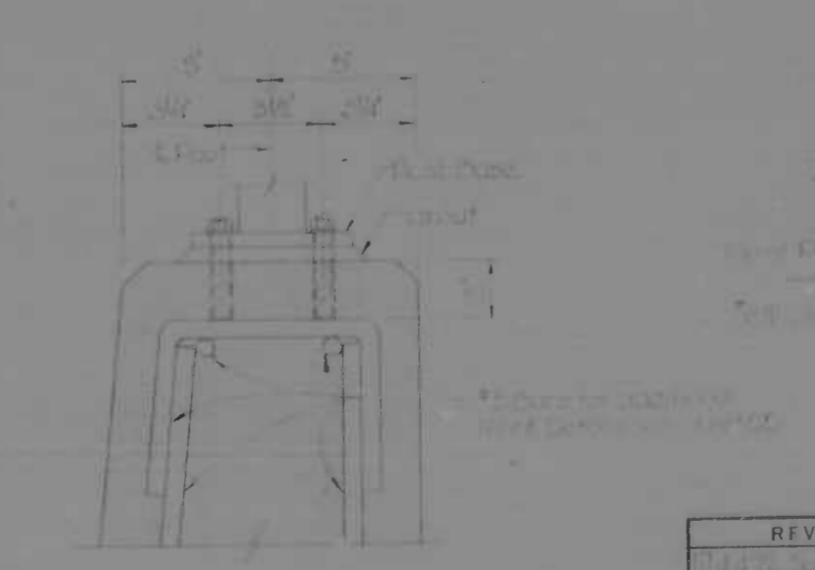

SECTION D
Scale 1/4" = 1'-0"

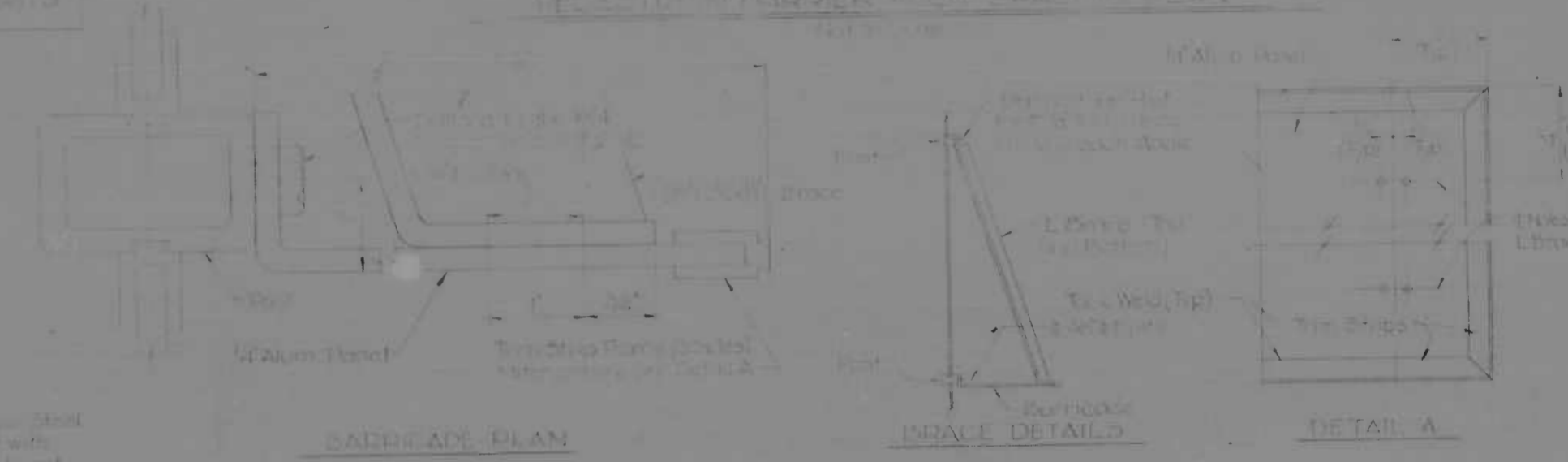

Barrier Details
Scale 1/4" = 1'-0"

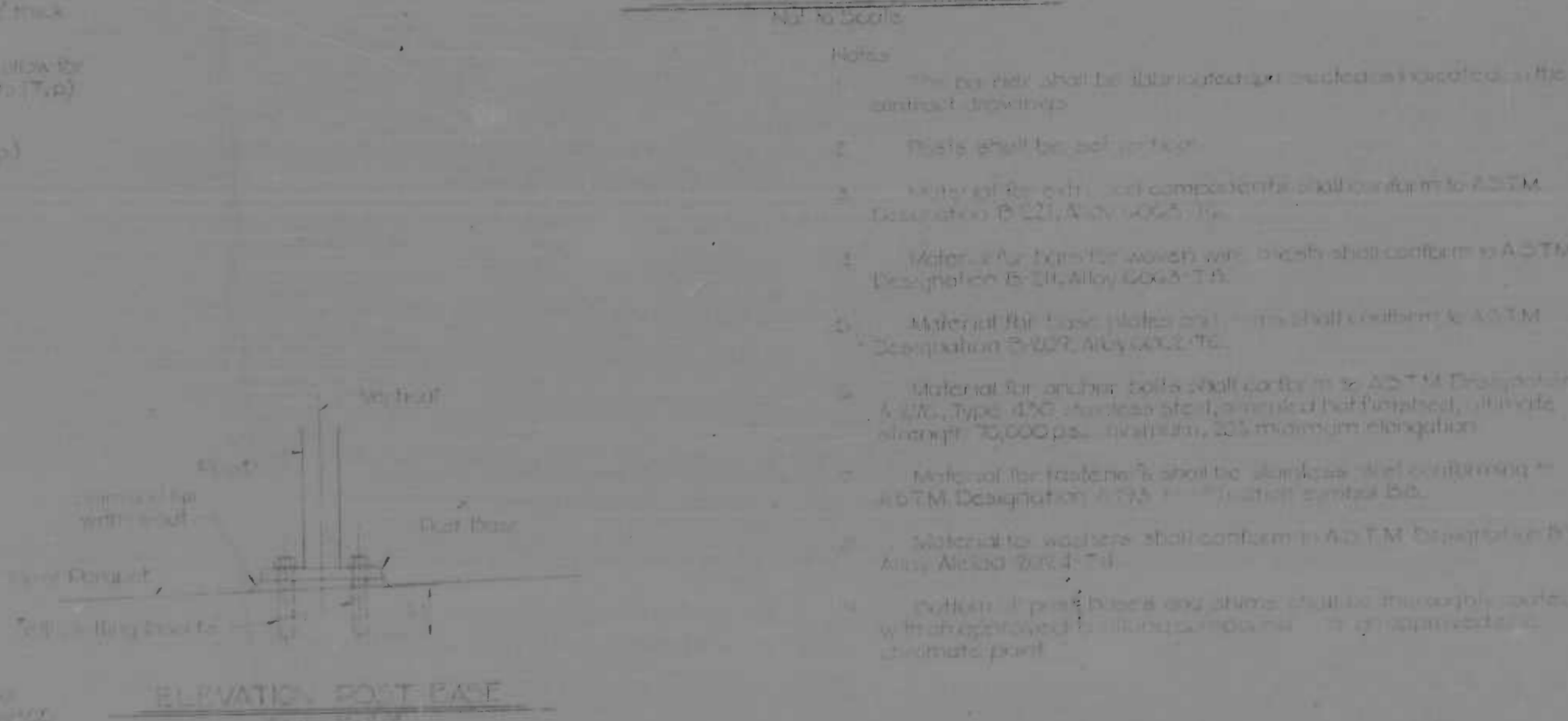

ELEVATION - POST BASE
Scale 1/4" = 1'-0"

- Notes:
1. This barrier shall be fabricated from galvanized steel.
 2. Posts shall be galvanized.
 3. Material for posts and components shall conform to ASTM Designation B-221, A193-4065-TB.
 4. Material for top rail shall conform to ASTM Designation B-221, A193-4065-TB.
 5. Material for base plates shall conform to ASTM Designation B-221, A193-4065-TB.
 6. Material for anchor bolts shall conform to ASTM Designation A-307, Type 470, minimum yield strength, ultimate strength 70,000 psi, maximum elongation.
 7. Material for fasteners shall be stainless steel conforming to ASTM Designation A-316, minimum yield strength 50,000 psi.
 8. Material for welds shall conform to ASTM Designation B-221, A193-4065-TB.
 9. All items of paint shall be applied to the barrier in accordance with approved specifications for galvanized steel.

REVISIONS	CONSULTANT	CITY OF BALTIMORE DEPARTMENT OF PUBLIC WORKS		STATE ROADS COMMISSION OF MARYLAND INTERSTATE DIVISION FOR BALTIMORE CITY	
1. (1/27/95) Supplemental (1/27/95)	Engineering Division	EASTERN AVE. OVER I-95 PEDESTRIAN PROTECTIVE BARRIER		SHEET NO. 89A of 113	
		SCALE	AS NOTED	DATE	AUG 15 1989

DES. NO.	MD	DES. NO.	9	SHEET NO.	113
REV. NO.		REV. NO.		SHEET NO.	

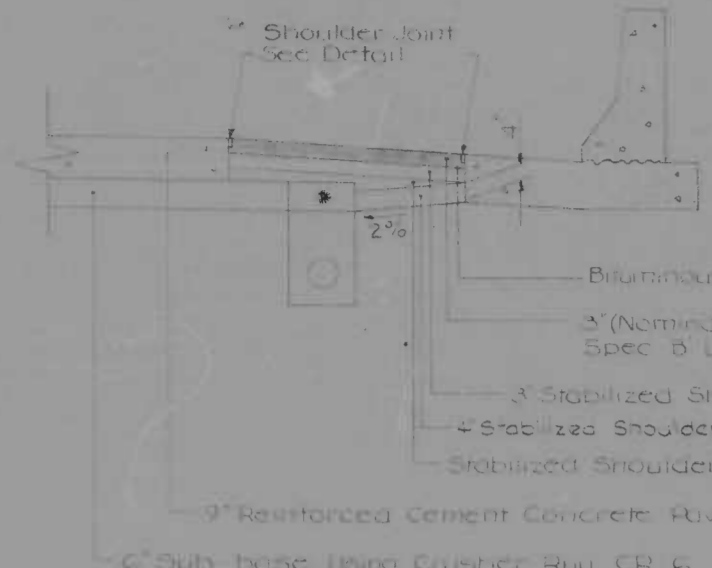

DETAIL C
Scale: 1/2"=1'-0"

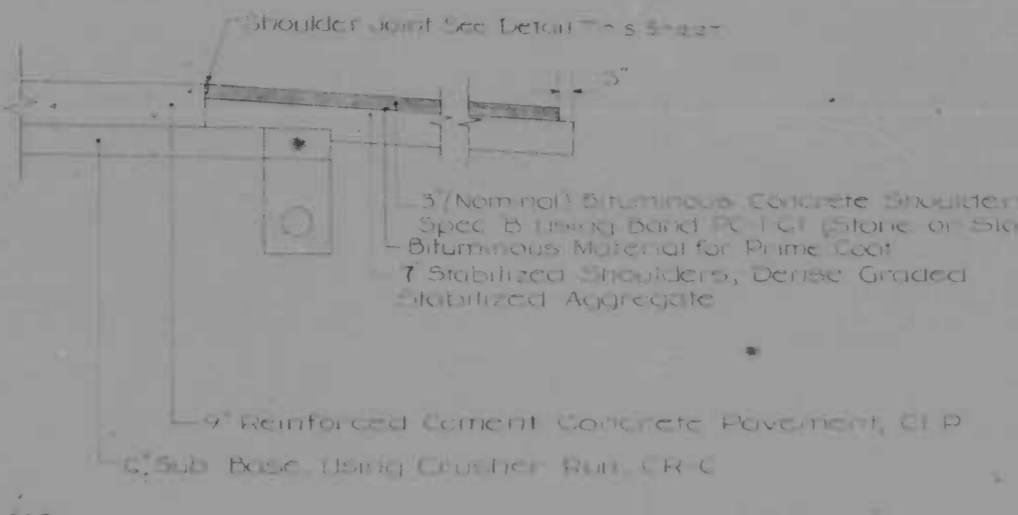

DETAIL E
Scale: 1/2"=1'-0"

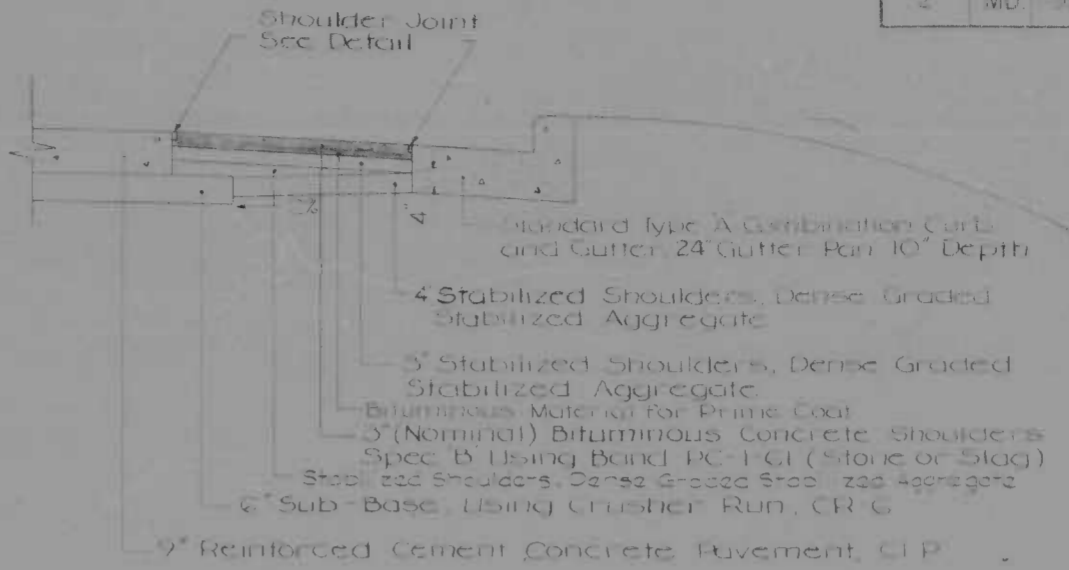

DETAIL F
Scale: 1/2"=1'-0"

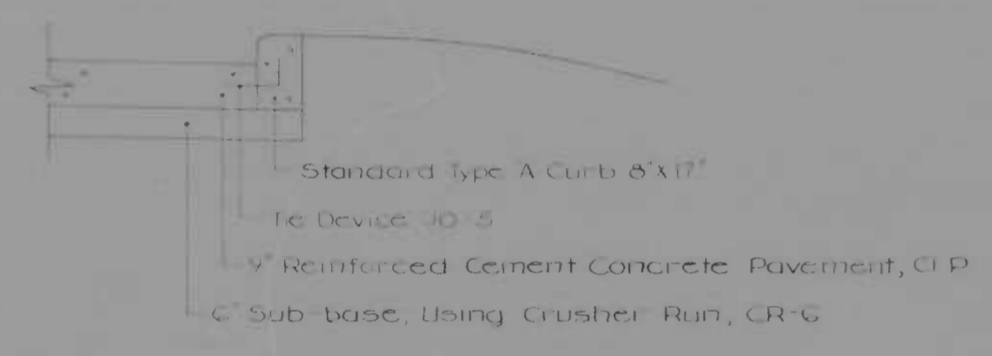

DETAIL G
Scale: 1/2"=1'-0"

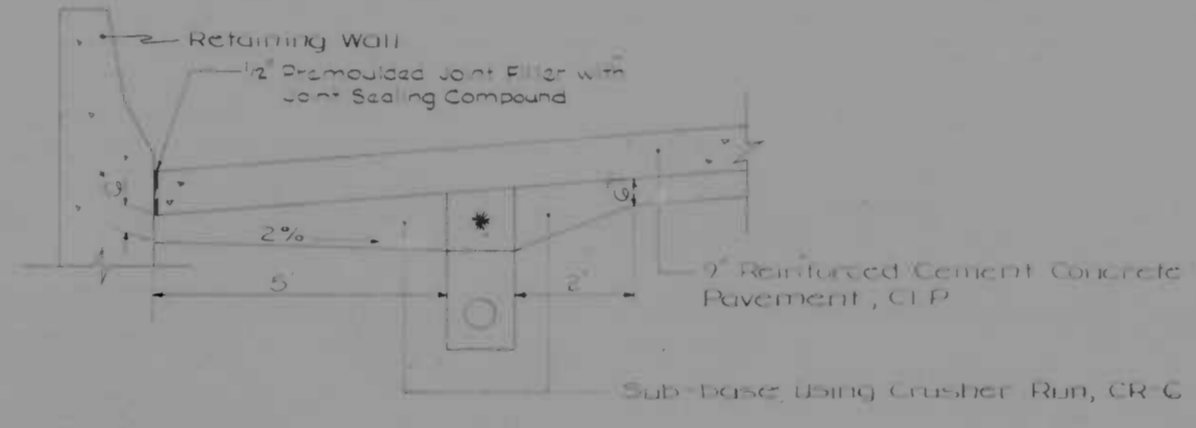

DETAIL H
Scale: 1/2"=1'-0"

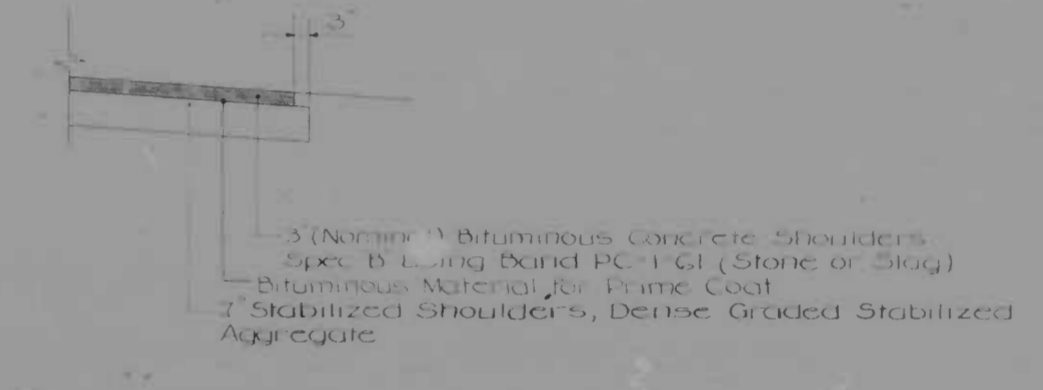

DETAIL J
Scale: 1/2"=1'-0"

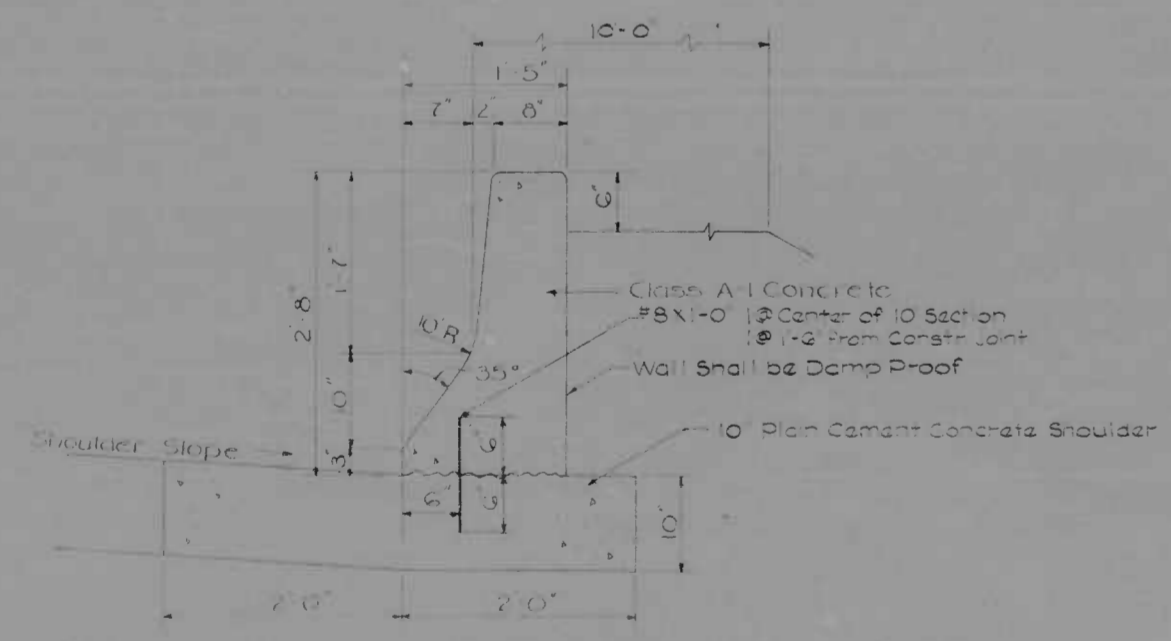

CONCRETE BARRIER
Scale: 1"=1'-0"

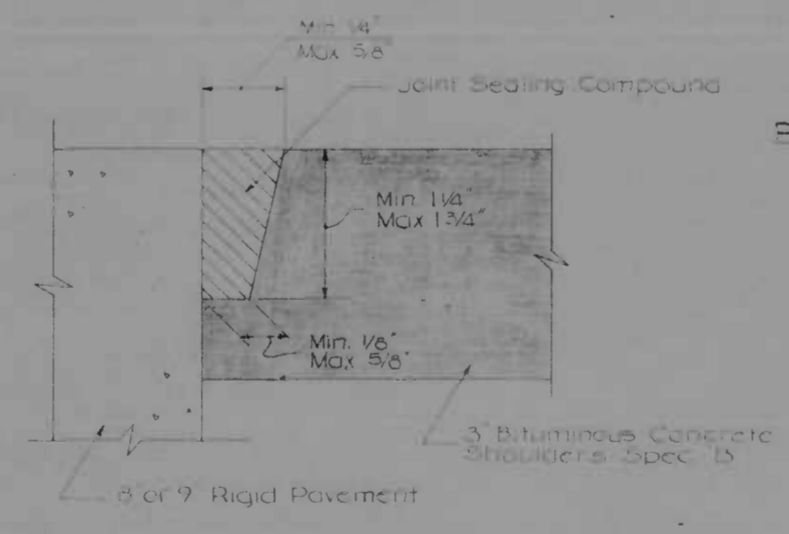

SHOULDER JOINT DETAIL
Not to Scale

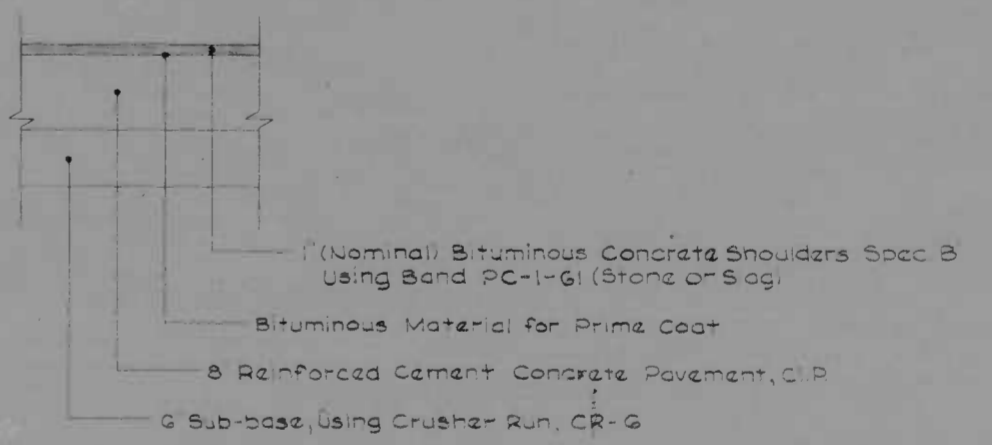
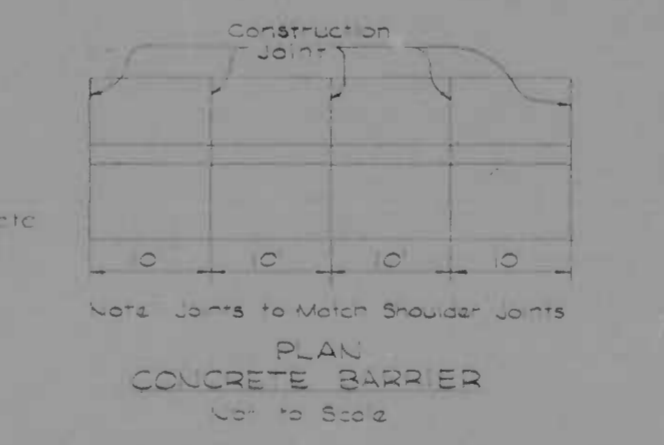
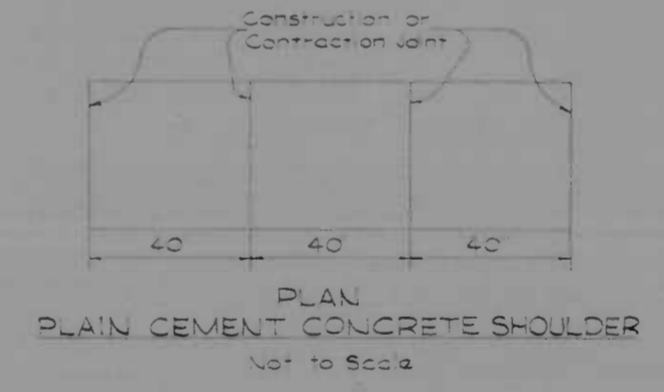

CONTRASTING PAVEMENT DETAIL
Scale: 1"=1'-0"

REVISIONS	CONSULTANT	CITY OF BALTIMORE DEPARTMENT OF PUBLIC WORKS	STATE ROADS COMMISSION OF MARYLAND INTERSTATE DIVISION FOR BALTIMORE CITY
	KNOTT, BENDER, STONE & ASSOC., INC. MATZ, DITERS & ASSOC., INC. CONSULTING ENGINEERS 241 N. CALVERT STREET BALTIMORE, MARYLAND 21202	INTERSTATE ROUTE 95 EASTERN AVENUE INTERCHANGE	DRAWN BY: JDM TRACED BY: JJK F.A.P. NO. 1-87-4137-M E.R.C. NO. BC 106-25-B10 BALTO. CITY NO. 9959
		DATE: 4-20-70	DEF. BY: DE'S CHK. BY: S.W.H. SHEET NO. 9 OF 113

F.P. NO.	DATE	BY	CHK.
2	MD	I-95-43236	SC 113

Stationing	1	2	3	4	5	6	7	8	9	10	11	12	13	14	15	16	17	18	19	20	21	22	23	24	25	26	27	28	29	30	31	32	33	34	35	36	37	38	39	40	41	42	43	44	45	46	47	48	49	50	51	52	53	54	55	56	57	58	59	60	61	62	63	64	65	66	67	68	69	70	71	72	73	74	75	76	77	78	79	80	81	82	83	84	85	86	87	88	89	90	91	92	93	94	95	96	97	98	99	100																																																																																																																																																																																																																																																																																																																																																																																																																																																																																																																																																																																																																																																																																																																																																																																																																																																																																		
81.00	81.02	81.04	81.06	81.08	81.10	81.12	81.14	81.16	81.18	81.20	81.22	81.24	81.26	81.28	81.30	81.32	81.34	81.36	81.38	81.40	81.42	81.44	81.46	81.48	81.50	81.52	81.54	81.56	81.58	81.60	81.62	81.64	81.66	81.68	81.70	81.72	81.74	81.76	81.78	81.80	81.82	81.84	81.86	81.88	81.90	81.92	81.94	81.96	81.98	82.00	82.02	82.04	82.06	82.08	82.10	82.12	82.14	82.16	82.18	82.20	82.22	82.24	82.26	82.28	82.30	82.32	82.34	82.36	82.38	82.40	82.42	82.44	82.46	82.48	82.50	82.52	82.54	82.56	82.58	82.60	82.62	82.64	82.66	82.68	82.70	82.72	82.74	82.76	82.78	82.80	82.82	82.84	82.86	82.88	82.90	82.92	82.94	82.96	82.98	83.00	83.02	83.04	83.06	83.08	83.10	83.12	83.14	83.16	83.18	83.20	83.22	83.24	83.26	83.28	83.30	83.32	83.34	83.36	83.38	83.40	83.42	83.44	83.46	83.48	83.50	83.52	83.54	83.56	83.58	83.60	83.62	83.64	83.66	83.68	83.70	83.72	83.74	83.76	83.78	83.80	83.82	83.84	83.86	83.88	83.90	83.92	83.94	83.96	83.98	84.00	84.02	84.04	84.06	84.08	84.10	84.12	84.14	84.16	84.18	84.20	84.22	84.24	84.26	84.28	84.30	84.32	84.34	84.36	84.38	84.40	84.42	84.44	84.46	84.48	84.50	84.52	84.54	84.56	84.58	84.60	84.62	84.64	84.66	84.68	84.70	84.72	84.74	84.76	84.78	84.80	84.82	84.84	84.86	84.88	84.90	84.92	84.94	84.96	84.98	85.00	85.02	85.04	85.06	85.08	85.10	85.12	85.14	85.16	85.18	85.20	85.22	85.24	85.26	85.28	85.30	85.32	85.34	85.36	85.38	85.40	85.42	85.44	85.46	85.48	85.50	85.52	85.54	85.56	85.58	85.60	85.62	85.64	85.66	85.68	85.70	85.72	85.74	85.76	85.78	85.80	85.82	85.84	85.86	85.88	85.90	85.92	85.94	85.96	85.98	86.00	86.02	86.04	86.06	86.08	86.10	86.12	86.14	86.16	86.18	86.20	86.22	86.24	86.26	86.28	86.30	86.32	86.34	86.36	86.38	86.40	86.42	86.44	86.46	86.48	86.50	86.52	86.54	86.56	86.58	86.60	86.62	86.64	86.66	86.68	86.70	86.72	86.74	86.76	86.78	86.80	86.82	86.84	86.86	86.88	86.90	86.92	86.94	86.96	86.98	87.00	87.02	87.04	87.06	87.08	87.10	87.12	87.14	87.16	87.18	87.20	87.22	87.24	87.26	87.28	87.30	87.32	87.34	87.36	87.38	87.40	87.42	87.44	87.46	87.48	87.50	87.52	87.54	87.56	87.58	87.60	87.62	87.64	87.66	87.68	87.70	87.72	87.74	87.76	87.78	87.80	87.82	87.84	87.86	87.88	87.90	87.92	87.94	87.96	87.98	88.00	88.02	88.04	88.06	88.08	88.10	88.12	88.14	88.16	88.18	88.20	88.22	88.24	88.26	88.28	88.30	88.32	88.34	88.36	88.38	88.40	88.42	88.44	88.46	88.48	88.50	88.52	88.54	88.56	88.58	88.60	88.62	88.64	88.66	88.68	88.70	88.72	88.74	88.76	88.78	88.80	88.82	88.84	88.86	88.88	88.90	88.92	88.94	88.96	88.98	89.00	89.02	89.04	89.06	89.08	89.10	89.12	89.14	89.16	89.18	89.20	89.22	89.24	89.26	89.28	89.30	89.32	89.34	89.36	89.38	89.40	89.42	89.44	89.46	89.48	89.50	89.52	89.54	89.56	89.58	89.60	89.62	89.64	89.66	89.68	89.70	89.72	89.74	89.76	89.78	89.80	89.82	89.84	89.86	89.88	89.90	89.92	89.94	89.96	89.98	90.00	90.02	90.04	90.06	90.08	90.10	90.12	90.14	90.16	90.18	90.20	90.22	90.24	90.26	90.28	90.30	90.32	90.34	90.36	90.38	90.40	90.42	90.44	90.46	90.48	90.50	90.52	90.54	90.56	90.58	90.60	90.62	90.64	90.66	90.68	90.70	90.72	90.74	90.76	90.78	90.80	90.82	90.84	90.86	90.88	90.90	90.92	90.94	90.96	90.98	91.00	91.02	91.04	91.06	91.08	91.10	91.12	91.14	91.16	91.18	91.20	91.22	91.24	91.26	91.28	91.30	91.32	91.34	91.36	91.38	91.40	91.42	91.44	91.46	91.48	91.50	91.52	91.54	91.56	91.58	91.60	91.62	91.64	91.66	91.68	91.70	91.72	91.74	91.76	91.78	91.80	91.82	91.84	91.86	91.88	91.90	91.92	91.94	91.96	91.98	92.00	92.02	92.04	92.06	92.08	92.10	92.12	92.14	92.16	92.18	92.20	92.22	92.24	92.26	92.28	92.30	92.32	92.34	92.36	92.38	92.40	92.42	92.44	92.46	92.48	92.50	92.52	92.54	92.56	92.58	92.60	92.62	92.64	92.66	92.68	92.70	92.72	92.74	92.76	92.78	92.80	92.82	92.84	92.86	92.88	92.90	92.92	92.94	92.96	92.98	93.00	93.02	93.04	93.06	93.08	93.10	93.12	93.14	93.16	93.18	93.20	93.22	93.24	93.26	93.28	93.30	93.32	93.34	93.36	93.38	93.40	93.42	93.44	93.46	93.48	93.50	93.52	93.54	93.56	93.58	93.60	93.62	93.64	93.66	93.68	93.70	93.72	93.74	93.76	93.78	93.80	93.82	93.84	93.86	93.88	93.90	93.92	93.94	93.96	93.98	94.00	94.02	94.04	94.06	94.08	94.10	94.12	94.14	94.16	94.18	94.20	94.22	94.24	94.26	94.28	94.30	94.32	94.34	94.36	94.38	94.40	94.42	94.44	94.46	94.48	94.50	94.52	94.54	94.56	94.58	94.60	94.62	94.64	94.66	94.68	94.70	94.72	94.74	94.76	94.78	94.80	94.82	94.84	94.86	94.88	94.90	94.92	94.94	94.96	94.98	95.00	95.02	95.04	95.06	95.08	95.10	95.12	95.14	95.16	95.18	95.20	95.22	95.24	95.26	95.28	95.30	95.32	95.34	95.36	95.38	95.40	95.42	95.44	95.46	95.48	95.50	95.52	95.54	95.56	95.58	95.60	95.62	95.64	95.66	95.68	95.70	95.72	95.74	95.76	95.78	95.80	95.82	95.84	95.86	95.88	95.90	95.92	95.94	95.96	95.98	96.00	96.02	96.04	96.06	96.08	96.10	96.12	96.14	96.16	96.18	96.20	96.22	96.24	96.26	96.28	96.30	96.32	96.34	96.36	96.38	96.40	96.42	96.44	96.46	96.48	96.50	96.52	96.54	96.56	96.58	96.60	96.62	96.64	96.66	96.68	96.70	96.72	96.74	96.76	96.78	96.80	96.82	96.84	96.86	96.88	96.90	96.92	96.94	96.96	96.98	97.00	97.02	97.04	97.06	97.08	97.10	97.12	97.14	97.16	97.18	97.20	97.22	97.24	97.26	97.28	97.30	97.32	97.34	97.36	97.38	97.40	97.42	97.44	97.46	97.48	97.50	97.52	97.54	97.56	97.58	97.60	97.62	97.64	97.66	97.68	97.70	97.72	97.74	97.76	97.78	97.80	97.82	97.84	97.86	97.88	97.90	97.92	97.94	97.96	97.98	98.00	98.02	98.04	98.06	98.08	98.10	98.12	98.14	98.16	98.18	98.20	98.22	98.24	98.26	98.28	98.30	98.32	98.34	98.36	98.38	98.40	98.42	98.44	98.46	98.48	98.50	98.52	98.54	98.56	98.58	98.60	98.62	98.64	98.66	98.68	98.70	98.72	98.74	98.76	98.78	98.80	98.82	98.84	98.86	98.88	98.90	98.92	98.94	98.96	98.98	99.00	99.02	99.04	99.06	99.08	99.10	99.12	99.14	99.16	99.18	99.20	99.22	99.24	99.26	99.28	99.30	99.32	99.34	99.36	99.38	99.40	99.42	99.44	99.46	99.48	99.50	99.52	99.54	99.56	99.58	99.60	99.62	99.64	99.66	99.68	99.70	99.72	99.74	99.76	99.78	99.80	99.82	99.84	99.86	99.88	99.90	99.92	99.94	99.96	99.98	100.00

DECK GRADES
Not to Scale

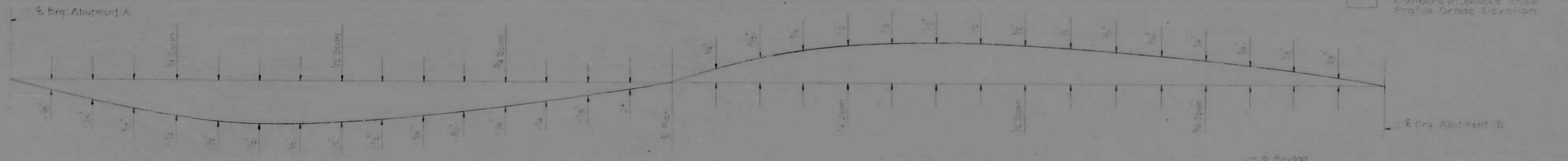

CAMBER DIAGRAM
Not to Scale



Note:
 1. Cambers shown are for total girder deflection due to dead loads and prestress force. The total deflection will be reduced about 1/3 after large work removal.
 2. Cambers for the structure shall be built without camber and the deck poured to grade.

DECK GRADE ELEVATION LOCATION
Not to Scale

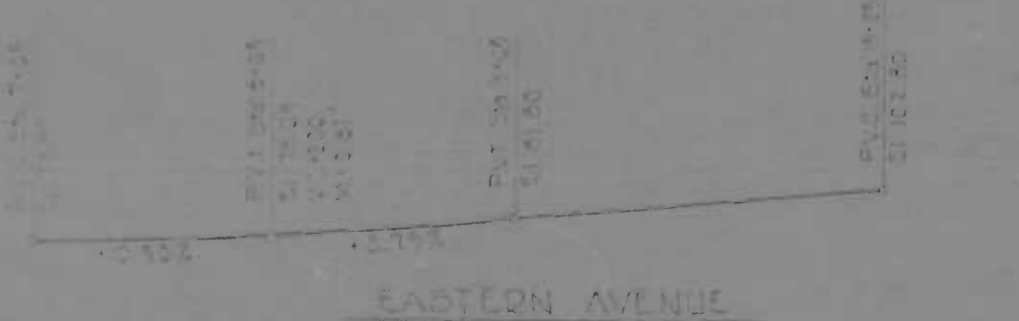

REVISIONS	CONSULTANT	CITY OF BALTIMORE DEPARTMENT OF PUBLIC WORKS	STATE ROADS COMMISSION OF MARYLAND INTERSTATE DIVISION FOR BALTIMORE CITY
	KNORR, BENDER, STONE & ASSOC., INC. and MATT, ERICCO & ASSOC., INC. CONSULTING ENGINEERS 931 N. CALVERT STREET BALTIMORE, MARYLAND 21202	EASTERN AVE. OVER I-95 DECK GRADES	DRAWN BY: [Signature] TRACED BY: [Signature] F.P. NO. I-95-43236 S.R.C. NO. BC 2457.0-52 BALTO. CITY NO. 1959
		SCALE: AS NOTED	DATE: AUG 1969

12/1/69 4/1/70

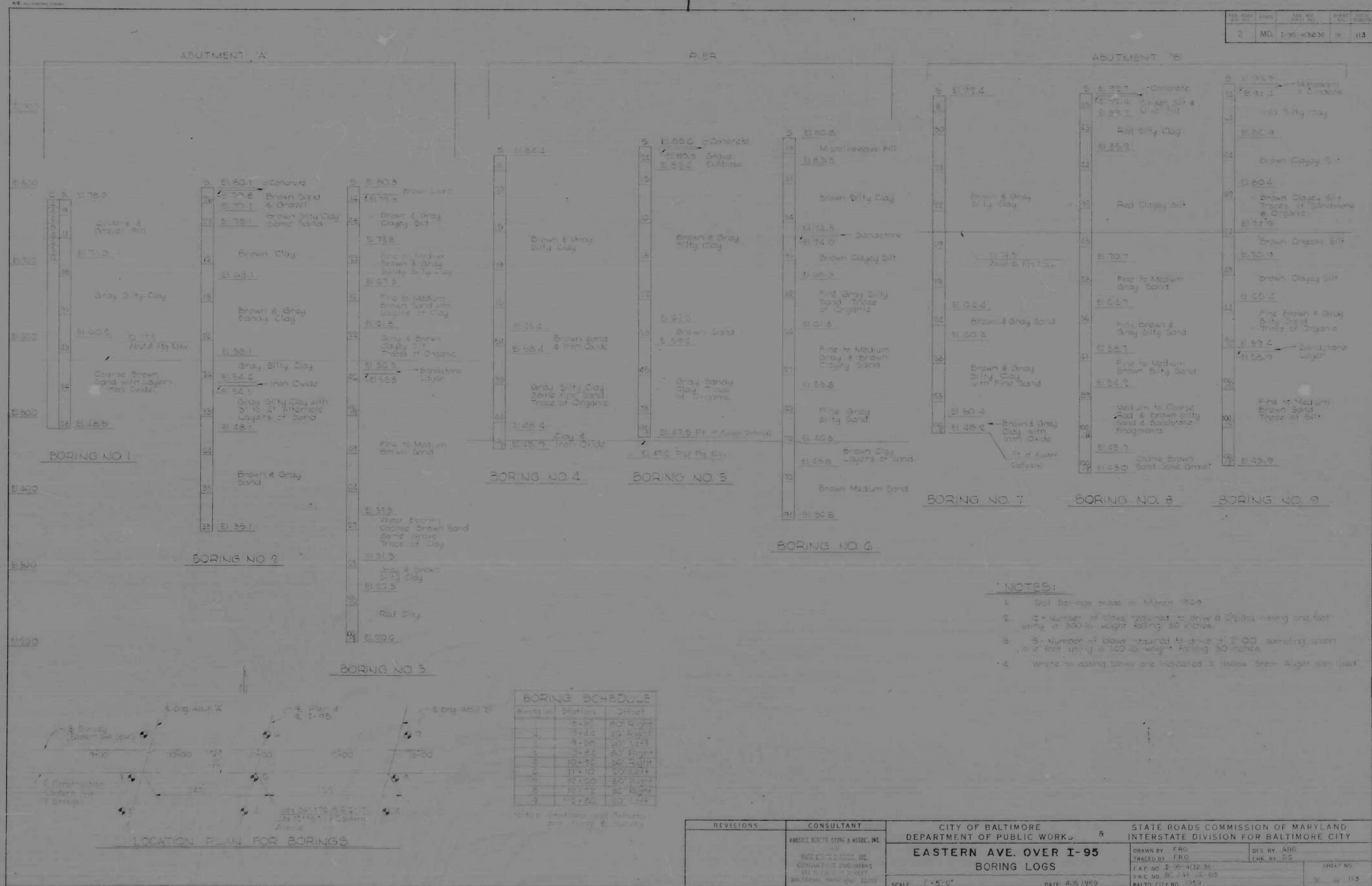

12111G5 4/1972

REVISIONS	CONSULTANT	CITY OF BALTIMORE DEPARTMENT OF PUBLIC WORKS	STATE ROADS COMMISSION OF MARYLAND INTERSTATE DIVISION FOR BALTIMORE CITY
	ENGINEER	FRANZ BLUMBERG & ASSOC., INC. 1117 N. CALVERT STREET BALTIMORE, MARYLAND 21202	DRAWN BY: FRG TRACED BY: FRG F.P. NO. I-95-43236 S.R.C. NO. 80-440-46-805 BALTO. CITY NO. 1959
DATE		AUG 1959	
SCALE		1" = 5'-0"	
SHEET NO.		113	

113	MD	I-95-4(32)36	97	113
-----	----	--------------	----	-----

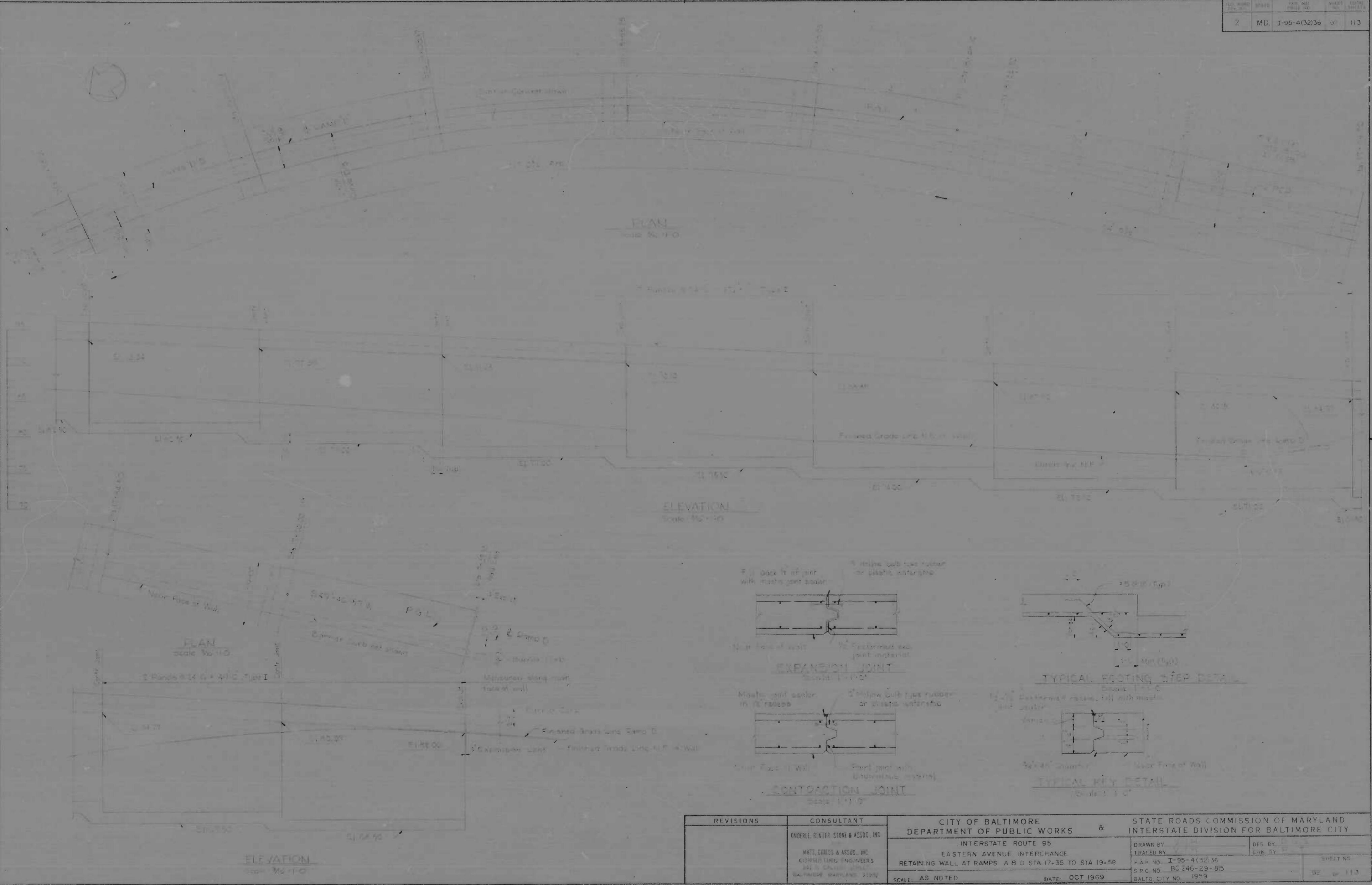

REVISIONS	CONSULTANT	CITY OF BALTIMORE DEPARTMENT OF PUBLIC WORKS	STATE ROADS COMMISSION OF MARYLAND INTERSTATE DIVISION FOR BALTIMORE CITY
	ENDRELL, BAUER, STONE & ASSOC., INC. NATE, DANIELS & ASSOC., INC. CONSULTING ENGINEERS 2410 CALVERT AVENUE BALTIMORE, MARYLAND 21202	INTERSTATE ROUTE 95 EASTERN AVENUE INTERCHANGE RETAINING WALL AT RAMPS A & D STA 17+35 TO STA 19+58	DRAWN BY: [] DES. BY: [] CHK. BY: [] F.A.P. NO. I-95-4(32)36 S.P.C. NO. BC 246-29-615 BALTO. CITY NO. 1959
		SCALE: AS NOTED	DATE: OCT 1969
			SHEET NO. 92 OF 113

10/11/69 41570

PROJECT NO.	STATE	DATE	SHEET NO.	TOTAL SHEETS
2	MD	1-24-1969	93	113

VERTICAL CURVE DATA	GRADE DATA
+45.78 +57.17 +75.00 +91.25 +105.75 +118.00	+23.00 +23.00 +23.00 +23.00 +23.00

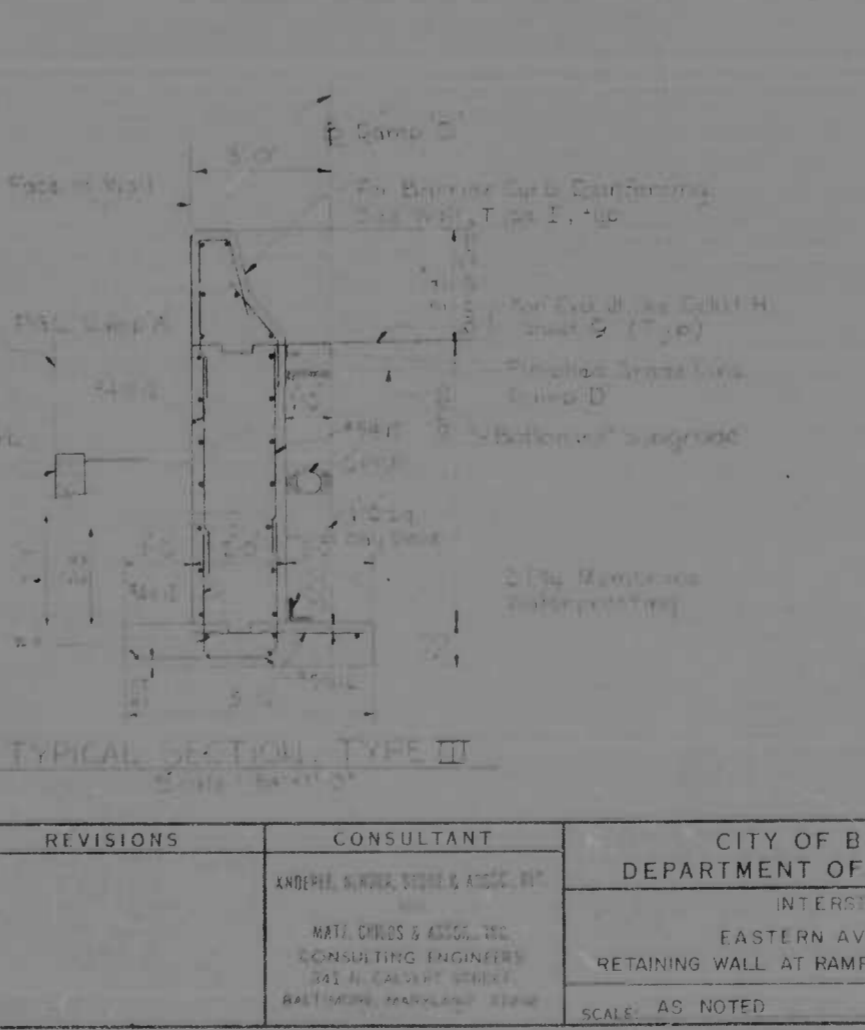
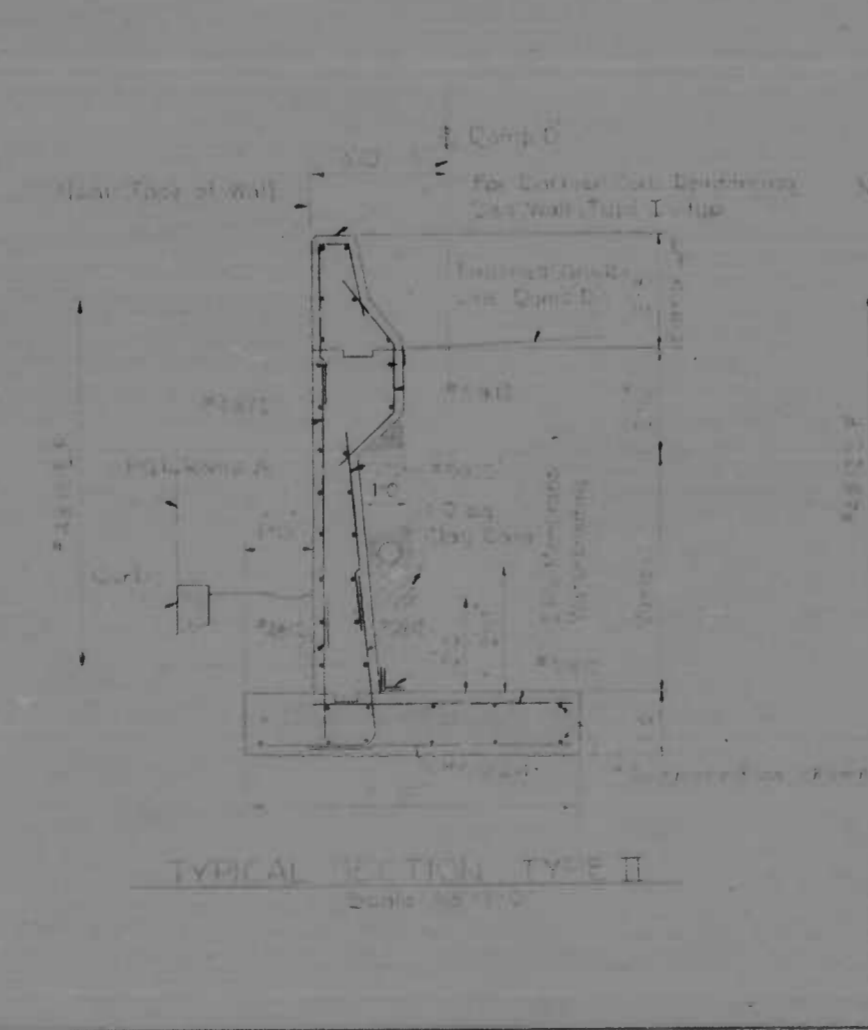
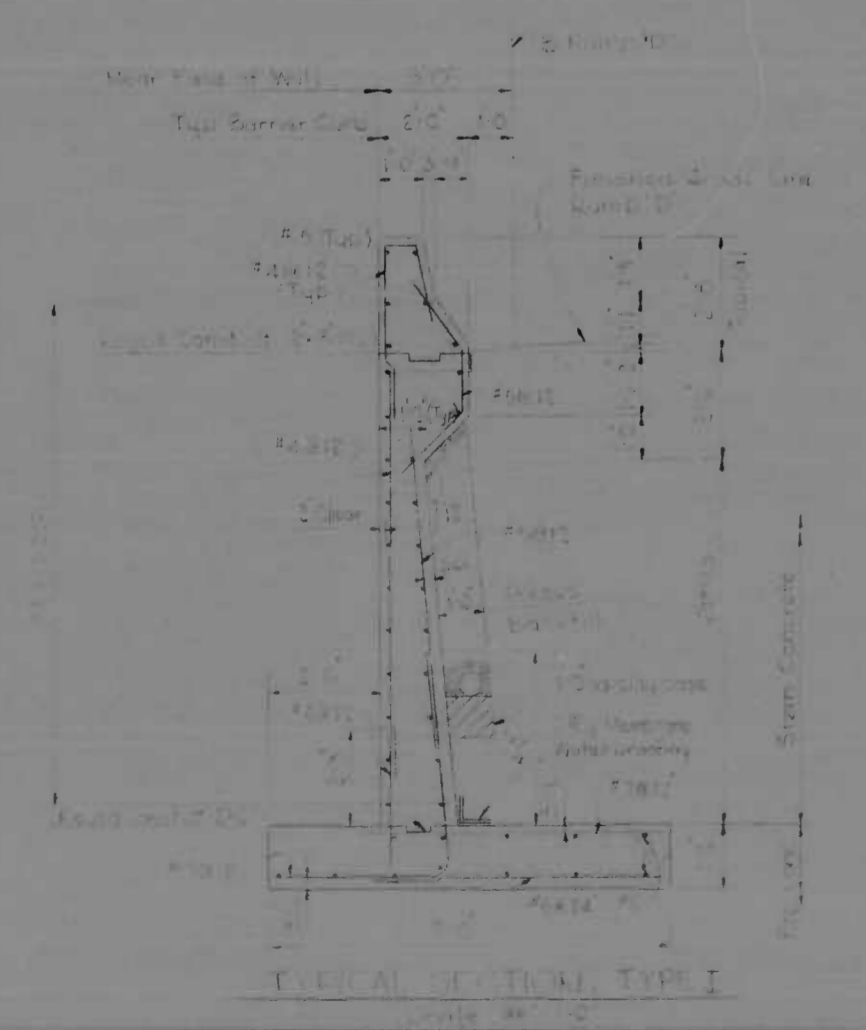

GENERAL NOTES

SPECIFICATIONS: Vertical C.C. Specifications and Section Specifications dated March 1958 and Special Provisions for Retaining Walls (Construction) A & B & C Standard Specifications for Highway Construction dated 1967 for design, including the 1975 interim Specifications for reinforced concrete walls, 11200psi.

CONCRETE: Class A Concrete shall have a minimum compressive strength of 3000 psi at 28 days. Use special provisions.

CHAMFER: All exposed corners of concrete walls shall be chamfered with 1/2" x 1/2" chamfer for a minimum of 12" on all corners.

REINFORCING STEEL: Galvanized steel reinforcement shall be used. Minimum lap length shall be 40 diameters. Minimum cover for bars shall be 2" unless otherwise noted.

EXCAVATION: See Section 11200psi.

FOUNDATION: Foundation shall be designed for a maximum settlement of 1" at any one point.

REVISIONS	CONSULTANT	CITY OF BALTIMORE DEPARTMENT OF PUBLIC WORKS & STATE ROADS COMMISSION OF MARYLAND INTERSTATE ROUTE 95	
	ANDRE, SHER, VIGOR & ASSOC., INC. 101 N. CALVERT STREET BALTIMORE, MARYLAND 21202	EASTERN AVENUE INTERCHANGE RETAINING WALL AT RAMPS A & D STA 19+58 TO STA 21+06	
		SCALE: AS NOTED	DATE: OCT 1969
		DRAWN BY: [Signature]	DES. BY: [Signature]
		TRACED BY: [Signature]	CHK. BY: [Signature]
		F.P. NO. I-95-4(3)236	SHEET NO. 93 of 113
		STATE NO. BC 246-15-815	
		BALTO. CITY NO. 1559	

2/11/69 D1876

FILE NO.	DATE	REVISED	SHEET	TOTAL
2	MD	I-95-43236	94	113

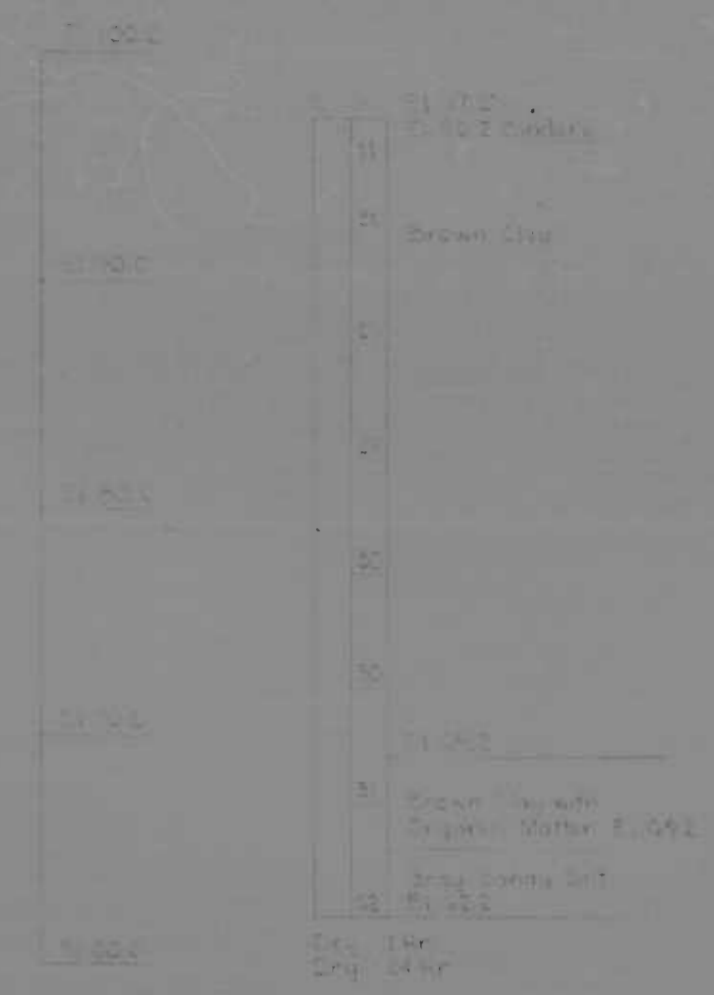

BORING NO. 1



BORING NO. 2



BORING NO. 3



BORING NO. 4

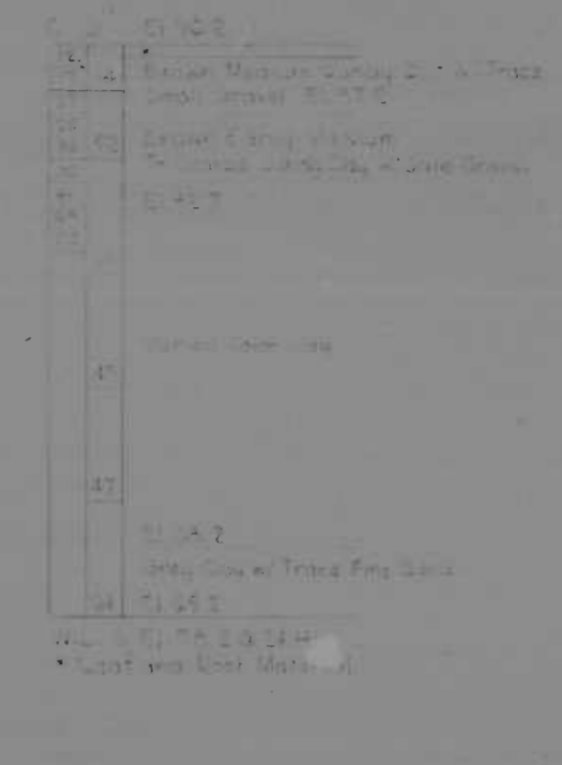

BORING NO. 5



LOCATION PLAN FOR BORINGS

Boring No.	Station	Depth
1	17+35	50
2	17+45	50
3	17+55	50
4	18+25	50
5	18+55	50

- NOTES:
1. Test borings made in accordance with...
 2. Number of blow counts recorded in each test is shown in the log.
 3. Soil samples were taken at 10, 20, 30, 40, and 50 feet depths.

REVISIONS	CONSULTANT	CITY OF BALTIMORE DEPARTMENT OF PUBLIC WORKS	STATE ROADS COMMISSION OF MARYLAND INTERSTATE DIVISION FOR BALTIMORE CITY
	FRANK B. ...	INTERSTATE ROUTE 95 EASTERN AVENUE INTERCHANGE RETAINING WALL AT RAMPS A B D STA 17+35 TO STA 21+06	DRAWN BY: V. H. ... DES. BY: C. H. ... F.A.P. NO. I-95-43236 S.P.C. NO. BC 246-29-815 BALTO. CITY NO. 1959
		SCALE: AS NOTED	DATE: OCT 1969
			SHEET NO. 94 OF 113

TABLE OF COORDINATES		
PT	NORTH	EAST
1	4832.72	22711.96
2	4837.59	22922.08
3	4893.82	22908.44
4	4872.09	22593.23
5	4892.03	22582.72
6	4903.28	22575.12

PROJ. NO.	STATE	FED. AID PROJ. NO.	SHEET NO.	TOTAL SHEETS
2	MD	I-95-4(32)36	95	113

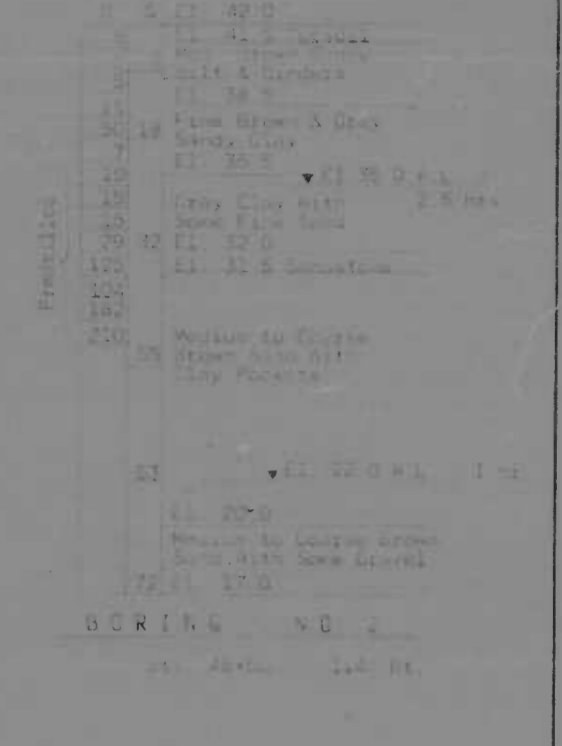
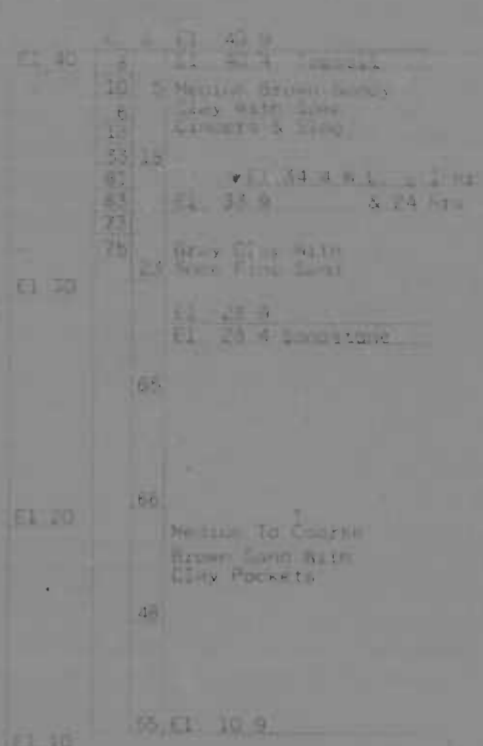
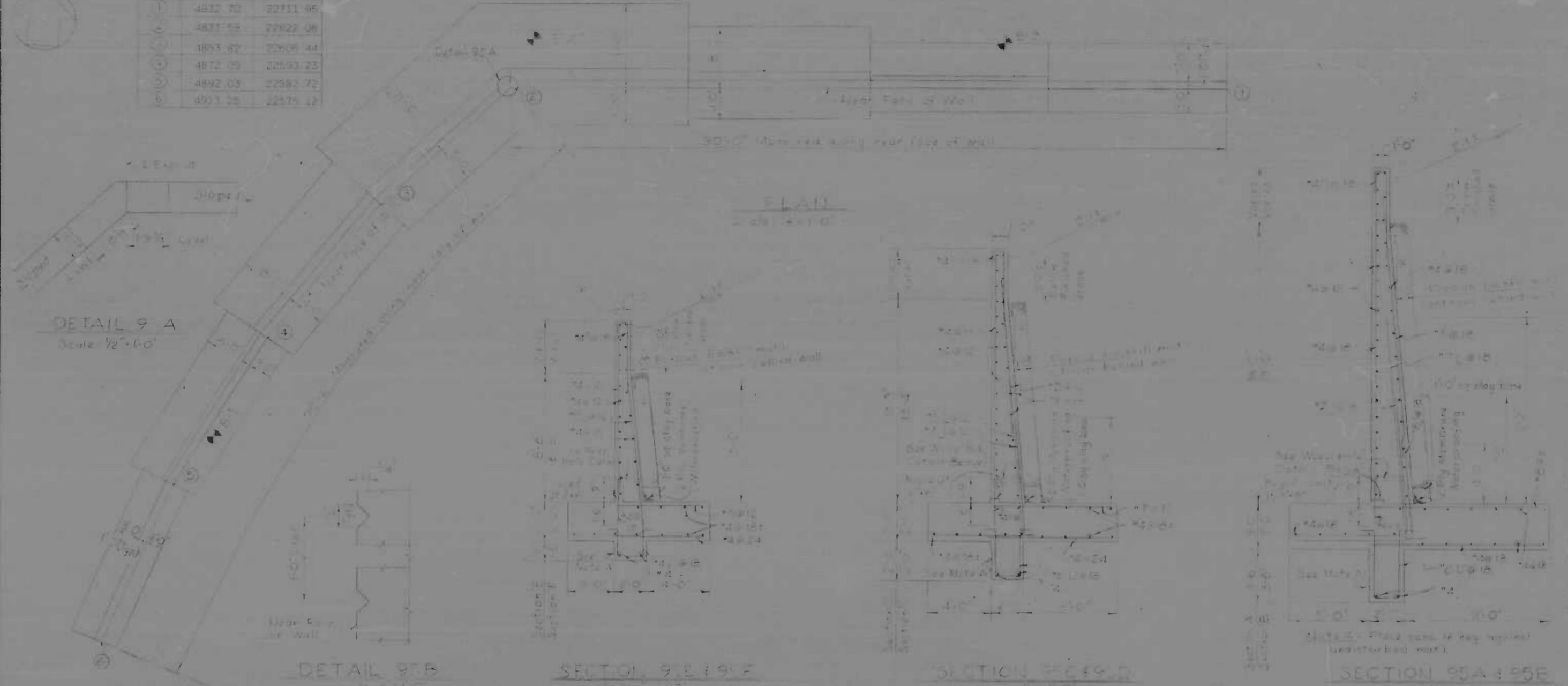

BORING NOTES

1. Test Borings made in April, 1970.
2. C = Number of blows required to drive a 2" O.D. casing one foot using a 140 lb. wt. falling 30 inches.
3. S = Number of blows required to drive a 2" O.D. standard spoon one foot using a 140 lb. wt. falling 30 inches.
4. Diagrams for borings are along P Survey East Avenue.

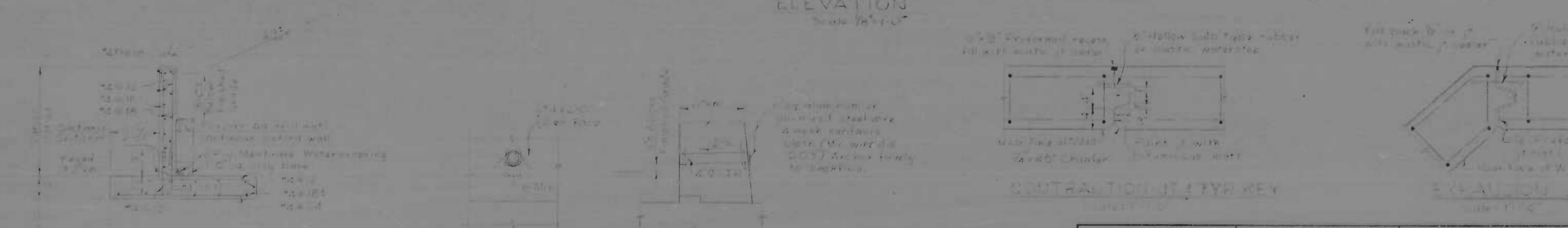
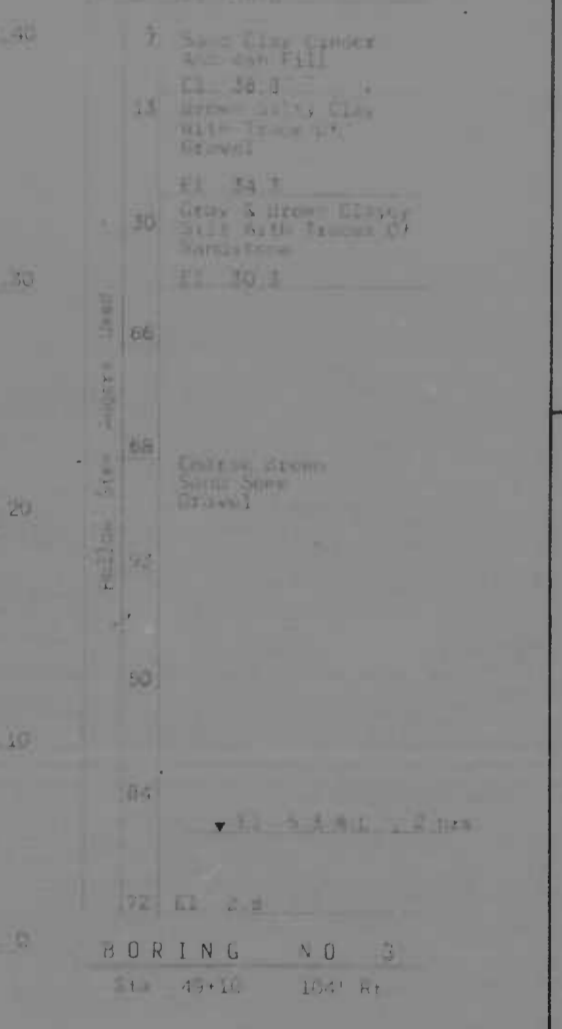
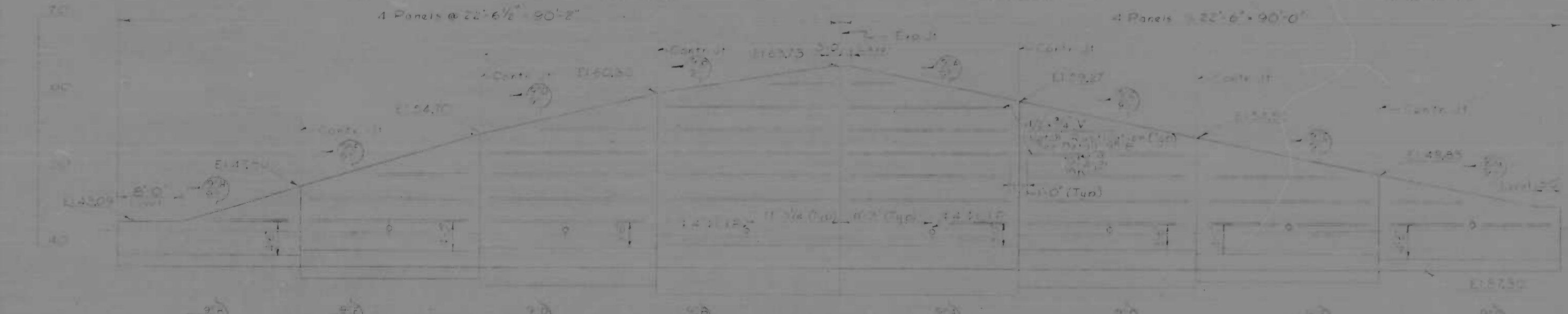

GENERAL NOTES

1. Footings are designed for a max. soil bearing value of 2.0 tons per square foot.
2. Backfill to front of wall to be done after removal of wall forms and before backfilling behind wall.
3. Maximum depth for any reinforcement shall be 3'.
4. For other notes see General Notes sheet 93 Retaining Wall at Howard & E.

REVISIONS	CONSULTANT	CITY OF BALTIMORE DEPARTMENT OF PUBLIC WORKS	STATE ROADS COMMISSION OF MARYLAND INTERSTATE DIVISION FOR BALTIMORE CITY
	WAT. CIVIL & MECH. ENGRS. CONDUCTING ENGR. 911 N. CALVERT ST. BALTIMORE, MARYL.	INTERSTATE ROUTE 95 EASTERN AVENUE INTERCHANGE RETAINING WALL I-95 STA. 330+ TO STA. 331+	DRAWN BY: W.R.A. TRACED BY: W.R.A. F.A.P. NO. I-95-4(32)36 S.R.C. NO. BC 246-26-B/5 BALTO. CITY NO. 1959
		SCALE: AS NOTED	DATE: APRIL 1970

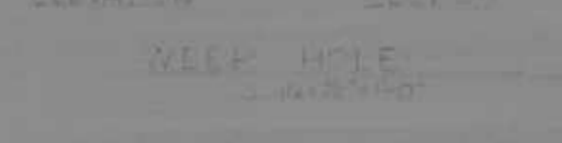
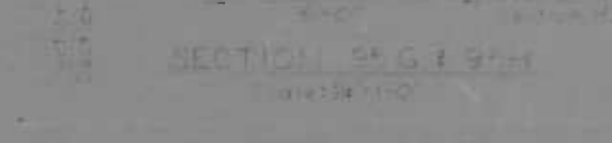

SUMMARY OF QUANTITIES

SHEET NO.	2	STATE	MD.	FED. AID PROJ. NO.	1-95-4-321-36	SHEET NO.	97	TOTAL SHEETS	113
-----------	---	-------	-----	--------------------	---------------	-----------	----	--------------	-----

STATION	GRADING					PIPE CLASS 4													DRAINAGE													REMARKS
	Class 2 Excavation	Removal of Existing Manure	Removal of Existing Manure	Removal of Existing Sidewalk	Trimming Existing Closures	PIPE CLASS 4													DRAINAGE													
						15"	18"	21"	24"	30"	36"	42"	48"	54"	60"	18" R.C.C.M. Pipe Class 5	42" R.C.C.M. Pipe Class 5	18" B.C.C.M. Pipe Type A - 12 Gauge	18" B.C.C.M. Pipe Type C - 14 Gauge	18" B.C.C.M. Pipe Type C - 12 Gauge	24" B.C.C.M. Pipe Type C - 14 Gauge	24" B.C.C.M. Pipe Type C - 12 Gauge	30" V.C. Pipe Extra Strength	30" x 15" Pipe Connection Brick Y	18" x 18" Pipe Connection Brick Y	21" x 18" Pipe Connection Brick Y	24" x 18" Pipe Connection Brick Y	30" x 18" Pipe Connection Brick Y	36" x 18" Pipe Connection Brick Y	42" x 18" Pipe Connection Brick Y	48" x 21" Pipe Connection Brick Y	
LF	LF	LF	LF	LF	LF	LF	LF	LF	LF	LF	LF	LF	LF	LF	LF	LF	LF	LF	EA	EA	EA	EA	EA	EA	EA	EA	EA	EA				
SHEET NO. 52																																
334+95																														M.H. 13 to Brick Curve		
345+95																														Brick Curve to Brick Curve		
347+00																														Brick Curve to M.H. 15		
344+15																														1-95 Lt.		
343+20																														Inlet 52 to M.H. 13		
346+30																														1-95 Lt.		
346+30																														Inlet 85 to Inlet 86		
346+30																														Ramp C Rt.		
343+15																														Ramp C Rt.		
343+15																														Ramp C Lt. & Rt.		
343+15																														1-95 Rt.		
343+15																														1-95 Rt.		
343+15																														Ramp A Rt.		
343+15																														Ramp A Rt.		
343+15																														Brick Curve to M.H. 12		
343+15																														M.H. 12 to Brick Curve		
343+15																														Inlet 63 to M.H. 12		
343+15																														Ramp A Rt.		
343+15																														Brick Curve to M.H. 14		
343+15																														Ramp A Rt.		
343+15																														M.H. 5 to M.H. 3		
343+15																														M.H. 3 to Inlet 20		
343+15																														Inlet 20 to Inlet 21		
343+15																														M.H. 3 to Brick Curve		
343+15																														M.H. 3 to M.H. 2		
343+15																														Eastern Avenue Rt.		
343+15																														M.H. 2 to Inlet 13		
343+15																														Eastern Avenue Lt.		
343+15																														Inlet 15 to Inlet 14		
343+15																														Eastern Avenue Rt.		
343+15																														Eastern Avenue Rt.		
343+15																														M.H. 4 to Inlet 19		
343+15																														Eastern Avenue Rt.		
343+15																														Inlet 10 to Inlet 11		
343+15																														Eastern Avenue Lt.		
343+15																														Ramp D Lt.		
343+15																														Ramp D Lt.		
343+15																														Ramp D Lt.		
343+15																														Ramp F Rt.		
343+15																														Eastern Avenue Rt.		
343+15																														Eastern Avenue Rt.		
343+15																														Eastern Avenue Lt.		
343+15																														Eastern Avenue Lt.		
343+15																														Eastern Avenue Rt.		
343+15																														Eastern Avenue Rt.		
343+15																														Eastern Avenue Lt.		
TOTAL THIS SHEET																																
TOTAL NO.	203	206	207	208	207	190	962	94	232	712	104																					

	REVISIONS NO. DESCRIPTION DATE	CONSULTANT KNOENEL, BENDER, STONE & ASSOC., INC. AND MATZ, CHILDS & ASSOC., INC. CONSULTING ENGINEERS 341 N. CALVERT STREET BALTIMORE, MARYLAND 21202	CITY OF BALTIMORE DEPARTMENT OF PUBLIC WORKS & INTERSTATE ROUTE 95 EASTERN AVENUE INTERCHANGE	STATE ROADS COMMISSION OF MARYLAND INTERSTATE DIVISION FOR BALTIMORE CITY DRAWN BY: JJK TRACED BY: JJK F.A.P. NO. 1-95-4-321-36 S.R.C. NO. BC 246-29-B15 BALTO. CITY NO. 1959	DES. BY: JGC CHK. BY: HFL SHEET NO. 97 of 113
--	--	--	---	--	--

SUMMARY OF QUANTITIES

FED. ROAD DIST. NO.	STATE	FED. AID PROJ. NO.	SHEET NO.	TOTAL SHEETS
2	MD.	95-432136	99	113

STATION	GRAVITY					DRAINAGE																		REMARKS									
	Class 2 Excavation	Removal of Existing Manhole	Removal of Existing Combination Curb & Gutter	Removal of Existing Sidewalk	Training Existing Ditches	18"	18"	21"	24"	30"	36"	42"	48"	54"	60"	18" R.C. Pipe Class 5	24" R.C. Pipe Class 5	18" B.C.C.M. Pipe Type A #12 Gauge	18" B.C.C.M. Pipe Type C #14 Gauge	24" B.C.C.M. Pipe Type C #12 Gauge	24" B.C.C.M. Pipe Type C #14 Gauge	24" x 10" Pipe Connection Brick Y	18" x 18" Pipe Connection Brick Y		21" x 18" Pipe Connection Brick Y	24" x 18" Pipe Connection Brick Y	30" x 18" Pipe Connection Brick Y	36" x 18" Pipe Connection Brick Y	42" x 18" Pipe Connection Brick Y	48" x 21" Pipe Connection Brick Y			
	LF	LF	LF	LF	LF	LF	LF	LF	LF	LF	LF	LF	LF	LF	LF	LF	LF	LF	LF	LF	LF	EA	EA	EA	EA	EA	EA	EA	EA				
SHEET NO. 55 (CONT.)																																	
366+30																																	
366+30																																	
366+30																																	
366+30																																	
365+30	3	4																															
366+30	45																																
366+80		4																															
SHEET NO. 56																																	
368+10	136																																
368+60																																	
368+60																																	
368+60																																	
368+60																																	
SHEET NO. 57																																	
6+85	2	3																															
8+00																																	
11+25					150																												
SHEET NO. 70																																	
16+00 to 21+00			28	19																													
SHEET NO. 71																																	
0+00 to 4+00			20	8																													
TOTAL THIS SHEET	186	11	48	27	150													84															
TOTAL	256	22	73	37	150	140	304	520	546	292	1396	400	1212	640	536	88	404	148	758	1152	268	974	364	92	24	1	2	1	1	3	11	4	1
IDENT. NO.	205	206	207	208	202	305	306	307	308	309	310	311	312	313	314	315	316	317	318	319	320	321	322	323	324	325	326	327	328	329	330	331	332

REVISIONS	CONSULTANT	CITY OF BALTIMORE DEPARTMENT OF PUBLIC WORKS	STATE ROADS COMMISSION OF MARYLAND INTERSTATE DIVISION FOR BALTIMORE CITY
	KNOX, BENDER, STONE & ASSOC., INC. AND MATZ, CHILDS & ASSOC., INC. CONSULTING ENGINEERS 949 N. EAGER STREET BALTIMORE, MARYLAND 21202	INTERSTATE ROUTE 95 EASTERN AVENUE INTERCHANGE	DRAWN BY: JJK TRACED BY: JJK F.A.P. NO. 1-95-432136 S.R.C. NO. BC 245-29-815 BALTO. CITY NO. 1959
		SCALE	DES. BY: JGC CHK. BY: HEL DATE: 6-3-70 SHEET NO. 99 OF 113

